

stûv₁₆

Pure simplicity

16

Stûv Stories +Stûv 16

Innovative
techniques for a
designer look that
really works

stuv.com

Stûv Stories

Welcome to the world of Stûv! Our products provide ways to layout and rearrange your interior. The story that they tell is straightforward and warm, simple and efficient. A story where appearance is functional and where objects blend into the architecture. Quality and perfection are the watchwords at Stûv. To improve is to simplify. This means humanising design. It also means constant innovation until a perfect harmony is found between pleasure and respect for the environment. Stûv is a state of mind.



Stûv Stories +Stûv 16

Design and technology in harmony



Model shown: Stûv 16/68-cube



Stûv Stories +Stûv 16-family

Innovative products
and a wide range of
heating solutions



The Stûv 16 family is totally unique, with its clean lines showcasing the flames to perfection. Ultra-enhanced combustion techniques guarantee fantastic performance. The endless possibilities that they offer mean that there is one perfect solution for every home. Stûv fires are easy to install, and particularly well suited to low-energy houses. Welcome home! Stûv 16... An innovative, out-of-the-ordinary range.

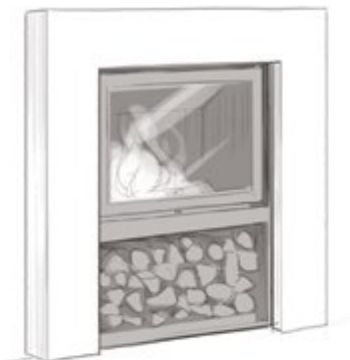

Stîv 16-fireplace

Stîv 16-up

Stîv 16-cube

Stûv Stories +Stûv 16-family... A large family that comes in a range of sizes!

The products are available in three widths:

- + Narrow model (Stûv 16/58) for logs of 33cm maximum
- + Medium model (Stûv 16/68) for logs of 50 m maximum
- + Wide model (Stûv 16/78) for logs of 60cm maximum



62,5 cm

78 cm

the dimensions are valid for all models



62,5 cm

68 cm



62,5 cm

58 cm

Stûv 16-tt

Stûv 16-in



clean
lines
pure energy

 Stûv Stories

- + Make the most of the sight of the flames and bask in their warmth!
- + Combustion is protected by a hinged door
- + Heat lasts longer
- + Option of an external air connection available for all Stûv 16 models





Stûv Stories +Stûv 16

Technical expertise
and attention to detail

Stûv Stories **+Stûv 16-cube**

- + The perfect solution for your main, occasional or atmospheric heat source
- + Can be laid on a Stûv base, a traditional base, or a piece of furniture
- + Ability to be connected to the outside air
- + Comes in three sizes
- + Optional fan

When performance
rises from the flames



Stöv 16-/68-cube with Stöv StuvGrey drawer bases



Functional,
sophisticated
and elegant

Stûv Stories +Stûv 16 base



- + Modular
- + Storage drawer
- + Compatible with the fan
- + Compatible with the external air connection
- + Movable log storage
- + Wide range of colours

Stûv Stories +Stûv 16-up

- + Panoramic, unrestricted view of the flames
- + Comes in three sizes
- + Ability to be connected to the outside air



The Stûv 16-up is always a wonderful surprise thanks to the warmth and atmosphere it adds to a home. The magic is largely thanks to its clean lines and simple elegance. The glass door offers a fantastic view of the flames. The visual effect of the suspended fire is the icing on the cake: the floor is clear, the room seems more spacious. The Stûv 16-up finishes off this impressive display with its excellent performance, thanks to its system of recovering heat from the combustion gases. Stûv 16-up: a suspended, flexible fire boasting fantastic performance.



Model shown: Stûv 16/58-up



Model shown: Stûv 16/58-H

Stûv Stories +Stûv 16-H

Fire in its purest
form and logs always
within reach

- + Model with log store
- + Comes in three sizes
- + Ability to be connected to the outside air

Frame my fire!



- + Model for flush-fitting
- + Comes in three sizes
- + Air-funnelling option
- + Ability to be connected to the outside air
- + Fan option

Model shown Stûv 16/58-in with applied frame

Stûv Stories +Stûv 16-in

Fancy an XXL fire? This is exactly what you'll get with the Stûv 16-in, with its panoramic view of the flames. Atmosphere and satisfaction guaranteed. Thanks to the innovative combustion system and exceptional output (over 75%), this is the perfect solution for your main or occasional heating needs. Designed to suit an existing or brand new fire, the Stûv 16-in is available in three sizes. Every home needs a Stûv!



Thin frame to disguise the thickness of the masonry

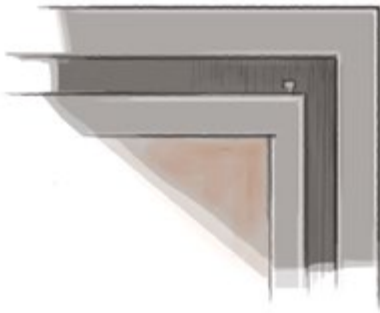

Mounted frame to hide the edges of the alcove

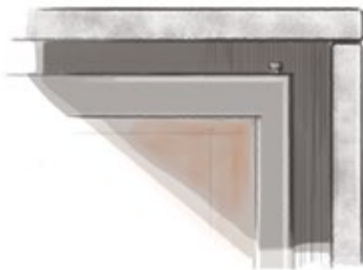

Frame can be customised with the decorative extras of your choice

Stûv Stories +Stûv 16–decorative fireplace

- + Model for flush-fitting, with decorative fire and integrated log store
- + Comes in three sizes
- + Air-funnelling option
- + Ability to channel convection air
- + Simple installation and finishing

At home in any home



Model shown: Stuv 16/78-fireplace

Ease of installation

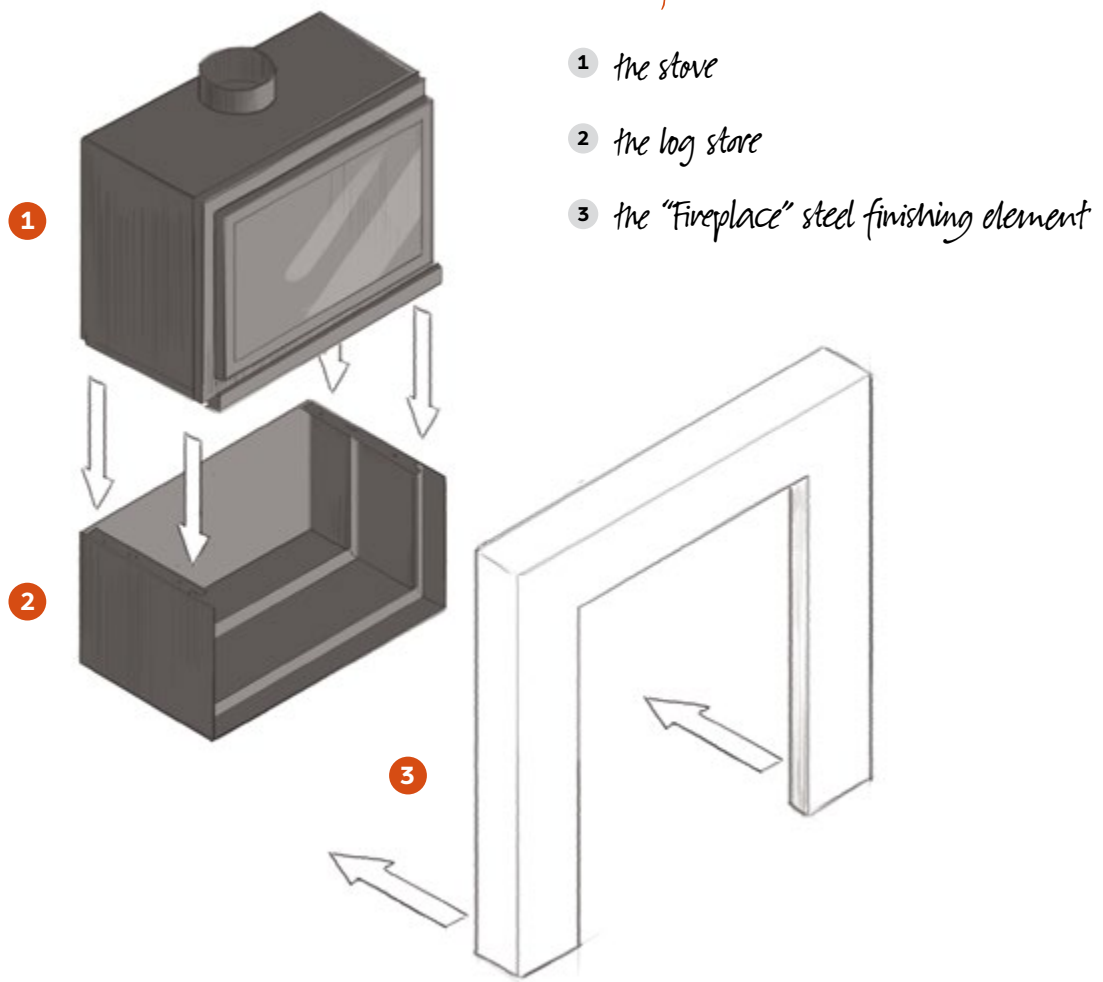

Stûv Stories +Stûv 16–decorative fireplace



A combination of
performance, ingenuity
and design



Adjustment of combustion air

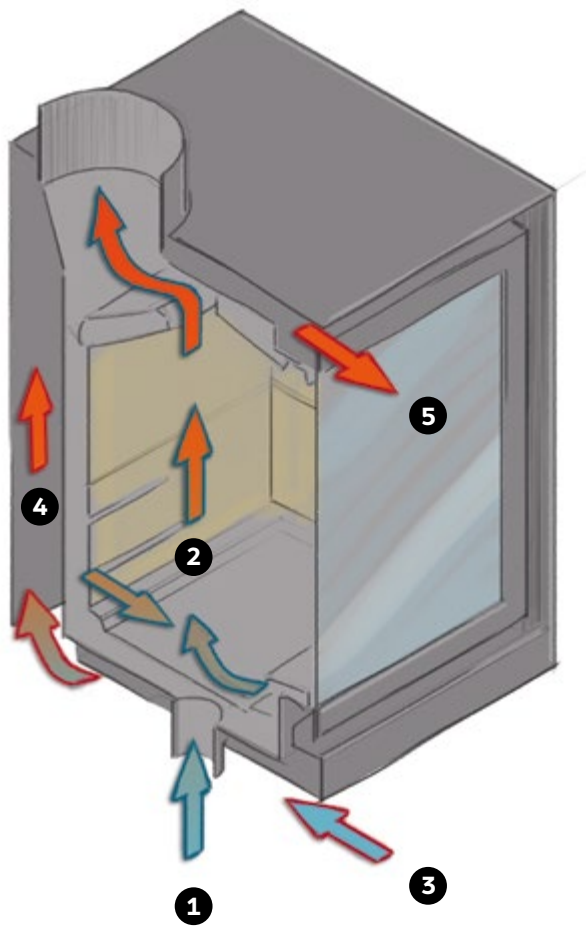

Combustion technique and air circulation Stûv 16

- 1** Combustion air.
Illustration with direct air intake under the stove. The outside air intake can also be located at the rear of the stove.
- 2** Combustion.
The air intake, the combustion chamber and smoke exhaust form an airtight system.
- 3** The air is taken into the room then heated by the stove.
- 4** The hot air is exchanged with the convection air which flows along the combustion chamber.
- 5** Hot air is circulated in the room by natural convection.

Stûv Stories +Stûv mobilobox and log trolley

- + Mobilobox: everything is always within reach (matches, cleaning products, wood etc.)
- + User-friendly log trolley, with clean, pure lines: a must-have accessory that looks great with all Stûv products.



A new era of
innovative solutions



Stûv 16

technical specifications

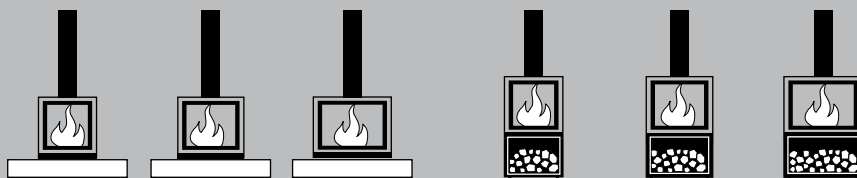

Technical specifications	16/58-cube	16/68-cube	16/78-cube	16/58-H	16/68-H	16/78-H
weight kg	105	113	121	136	147	158
nominal heat power kW	7	7,5	8	7	7,5	8
optimum output range kW	5-8	5-9	6-10	5-8	5-9	6-10
efficiency %	78	77	75	78	77	75
CO emissions %	0,09	0,10	0,09	0,09	0,10	0,09
particle emissions mg/Nm ³	11	19	13	11	19	13
energy efficiency index (EEI)	104	103	100	104	103	100
energy efficiency class	A	A	A	A	A	A
range of wood consumption** kg/h	1,4-2,3	1,5-2,6	1,8-3,0	1,4-2,3	1,5-2,6	1,8-3,0
length of logs V/H - cm	-/40	-/50	-/60	-/40	-/50	-/60
outside air intake ø mm	63	63	63	63	63	63

Options	16/58-cube	16/68-cube	16/78-cube	16/58-H	16/68-H	16/78-H
+ bases	o	o	o	-	-	-
+ log trolley	o	o	o	-	-	-
+ outside air connection	o	o	o	o	o	o
+ smoke outlet upwards	s	s	s	s	s	s
+ electric fan	o	o	o	-	-	-
+ wood holder	-	-	-	s	s	s

Dimensions	16/58-cube	16/68-cube	16/78-cube	16/58-H	16/68-H	16/78-H
(A) width mm	580	680	780	580	680	780

** at 12 % humidity

V/H vertical position/horizontal position

o optional

s standard

- not available

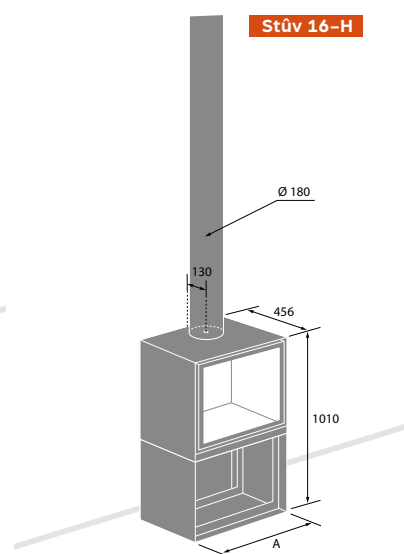
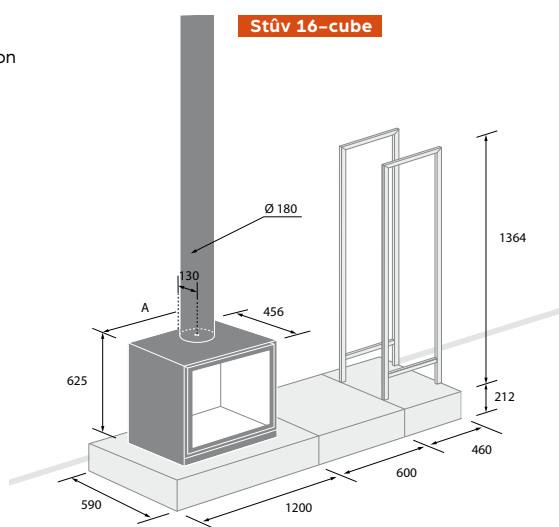

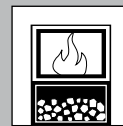

16/58-up	16/68-up	16/78-up	16/58-in	16/68-in	16/78-in	16/58-firep.	16/68-firep.	16/78-firep.
113	122	130	91	102	112	113	122	130
7	7,5	8	7	7,5	8	7	7,5	8
5-8	5-9	6-10	5-8	5-9	6-10	5-8	5-9	6-10
78	77	75	78	77	75	78	77	75
0,09	0,10	0,09	0,09	0,10	0,09	0,09	0,10	0,09
11	19	13	11	19	13	11	19	13
104	103	100	104	103	100	104	103	100
A	A	A	A	A	A	A	A	A
1,4-2,3	1,5-2,6	1,8-3,0	1,4-2,3	1,5-2,6	1,8-3,0	1,4-2,3	1,5-2,6	1,8-3,0
-/40	-/50	-/60	-/40	-/50	-/60	-/40	-/50	-/60
63	63	63	63	63	63	63	63	63
16/58-up	16/68-up	16/78-up	16/58-in	16/68-in	16/78-in	16/58-firep.	16/68-firep.	16/78-firep.
-	-	-	-	-	-	-	-	-
-	-	-	-	-	-	-	-	-
o	o	o	o	o	o	o	o	o
s	s	s	s	s	s	s	s	s
-	-	-	o	o	o	-	-	-
-	-	-	-	-	-	s	s	s
16/58-up	16/68-up	16/78-up	16/58-in	16/68-in	16/78-in	16/58-firep.	16/68-firep.	16/78-firep.
580	680	780	580	680	780	580	680	780

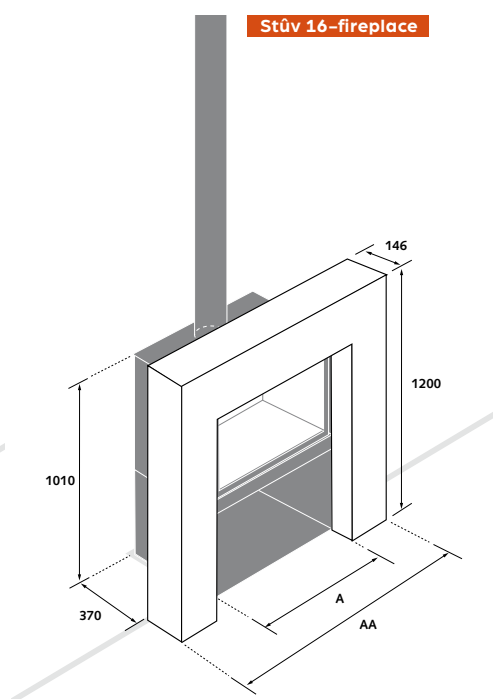
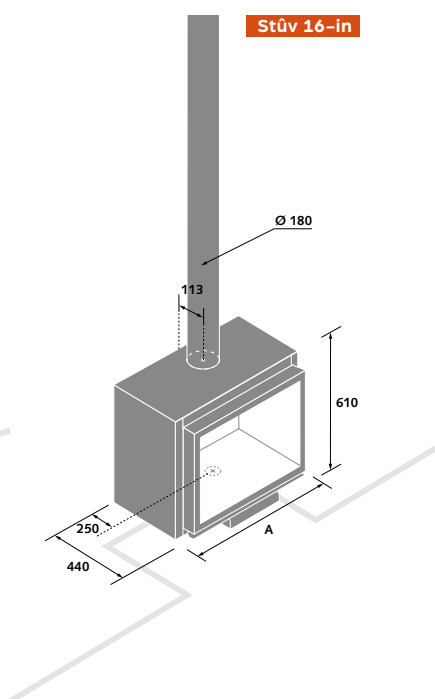
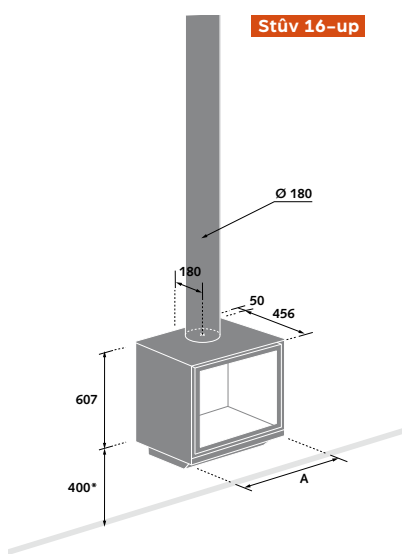

The constant search for improvement...

Stûv invests enormously in research and development in both its own laboratory and thanks to its partnerships with specialists in the field of combustion. Each detail is important in optimising the performance of the stove. Stûv devices meet the most stringent standards in terms of respect for the environment. We give priority to ergonomics and simplicity at all stages – installation, use, maintenance – so that every user can use their Stûv exactly how they want it. This is the reason we provide detailed installation instructions, we select our sales network and organise training sessions for our retail and installation partners.

The Stûv guarantee

- + Stûv fires are renowned for their design and performance. They are also solid, reliable and durable.
- + The fires and their components are made in Europe with the utmost care. A well-maintained Stûv fire is for life.
- + This is why Stûv offers the users of its products an extended guarantee. Three years' guarantee in addition to the legal guarantee.
- + In total, 5 years on the body of the fire, 3 years on the electrical components and 3 years on the other components.

What do you need to do to benefit from this extended guarantee?

Complete the guarantee form that you will find at the end of the user manual and return the hard copy to Stûv or – the easier option – complete the online form at stuv.com.



All Stûv fires are designed to burn wood with a humidity level of less than 20 %.

All Stûv fires were tested according to EN 13240 CE and EN 13229.

Complies with standards :

BimSchV2(DE), OPair (CH), Din+ (EU), BE Phase 3 (BE), AEA1 (CH)

Colophon

design Brigitte Boits

photography François Chevalier

styling Edith Vervest

copy JP Nieuwerkerk

communication manager Serge Alhadeff

responsible editor Gérard Pitance

Documents and photos are for information purposes only. Stûv reserves the right to make changes without warning. Every care has been taken in the preparation of this brochure; however, we do not accept any responsibility for any mistakes that it may contain.

Stûv Stories

+ Find out about all
the products in the
Stûv range

+ wood

Stûv 16 | Stûv 21 | Stûv 22 |

Stûv 30 | Stûv 30-compact |

Stûv microMega

+ gas

Stûv tulp

+ pellets

Stûv P-10

Stûv stoves are distributed by :

Stûv stoves are designed and
manufactured by: **Stûv nv**
rue Jules Borbouse 4
B - 5170 Bois - de - Villers
Belgium
info@stuv.com
stuv.com

join us



stûv

The essential fire