

SCULPT™

FIREPLACE
COLLECTION

SEGUIN

Europa 7 | Europa 7 VL | Multivision 8000 Series

Super 9 | Visio 8 Plus

INSTALLATION & USER GUIDE

1. SPECIFICATIONS

2. PRELIMINARY INSTALL GUIDE

3. COMPONENTS LIST

4.0 INBUILT AGAINST COMBUSTIBLE WALL

4.1 MASONRY BRICK INSTALLATION

4.2 HEBEL INSTALLATION

4.3 SKAMOL: REFER TO SKAMOTEC 225 MANUAL

5. INBUILT INTO ISLAND WALL NO COMBUSTIBLE SURROUNDINGS

6. EXISTING CHIMNEY INSTALL

7. FREE STANDING INSTALL

8. LIFT UP DOOR ASSEMBLY

9. OPERATION & MAINTENANCE

10. WARRANTY

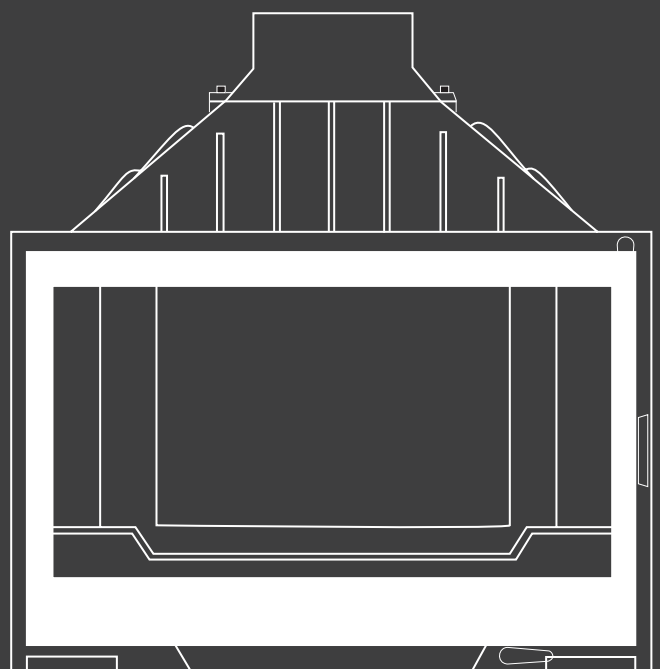

NOTICE TO INSTALLER:

These instructions must be left with the owner, who should keep them for future use.

COMPLIANCE PLATE AND SERIAL NUMBER.

The instructions in this manual are recommendations only, the distributor and manufacturer bears no liability to the interpretation of these instructions. Please ensure to download the latest version of this manual from our website: www.sculptfireplaces.com.au/installation-manuals/

© Copyright 2021 Sculpt Fireplaces Collection

CONGRATULATIONS!

Thank you for choosing **Sculpt Fireplaces** as your heater of choice.

Your fireplace is the result of careful design, artisan engineering and safety tests. If it is properly installed, used and maintained, you may be sure that you will have an outstanding heating feature in your home for years to come.

We advise you to read through this guide in order to become acquainted with the installation methods specific to your fireplace.

It is recommended that this fireplace be installed by a qualified and licensed trades professional. You will find in this guide the answers to most of your questions, should you require further assistance we recommend you contact your retailer.

Before igniting your fireplace for the first time, please carefully read this manual.

Follow **@sculptfireplacecollection** on Instagram, **Sculpt Fireplace Collection** on Facebook and be sure to post your latest masterpiece installed with the hashtag **#sculptfires**.

We hope we've helped make you the envy of your friends this winter and for years to come.

**From all of us,
Sculpt Fireplace Collection**

** Dimensions show include lift up door option, exclude these dimensions for swing door model

* for inbuilt models only

ALL FIREPLACES IN THIS MANUAL CONFORM TO AUSTRALIAN AND NEW ZEALAND STANDARDS AS/NZS 2918:2018 DOMESTIC SOLID FUEL BURNING APPLIANCES & AS/NZS 4012/4013(2014).

IMPORTANT

Heating capacity of the following appliances are a guide only and refers to areas with 2.4m ceilings and 6 or more star rated buildings. Heating output may vary depending on factors such as building characteristics, quality of insulation, type of firewood used and climate zone.

All dimensions shown are approximate. Check all dimensions accurately prior to installation. In line with our policy of continuous improvement, we reserve the right to alter specifications without notice.

All units comply and **MUST** be installed to Australian & New Zealand Standard AS/NZS 2918:2018. When in use some parts may become hot. A suitable fire guard is recommended where very young, elderly or infirm are concerned.

The instructions in this manual are recommendations only, the distributor and manufacturer bears no liability to the interpretation of these instructions.

© Copyright 2021 Sculpt Fireplaces Collection

SEGUIN EUROPA 7

MATERIAL	100% Pure cast iron, 8-12mm thickness
KW OUTPUT	17.9kW
HEATING CAPACITY	Up to 150-250m ² *
FACADE	Clean frame-less design (trim options available)
GLASS DOOR	Secure swing or lift up door opening system
MINIMUM FLUE HEIGHT	4.5m
FLUE SIZES	200mm, 250mm, 300mm
INCLUDES HOT AIR KIT	A duct and a register
OUTSIDE AIR KIT	Recommended for well insulated homes
WARRANTY	10 year firebox warranty**
WEIGHT	170kg
HEARTH DIMENSIONS	Min 500mm in front of any part of fireplace, 250mm on either side & 75mm thick***

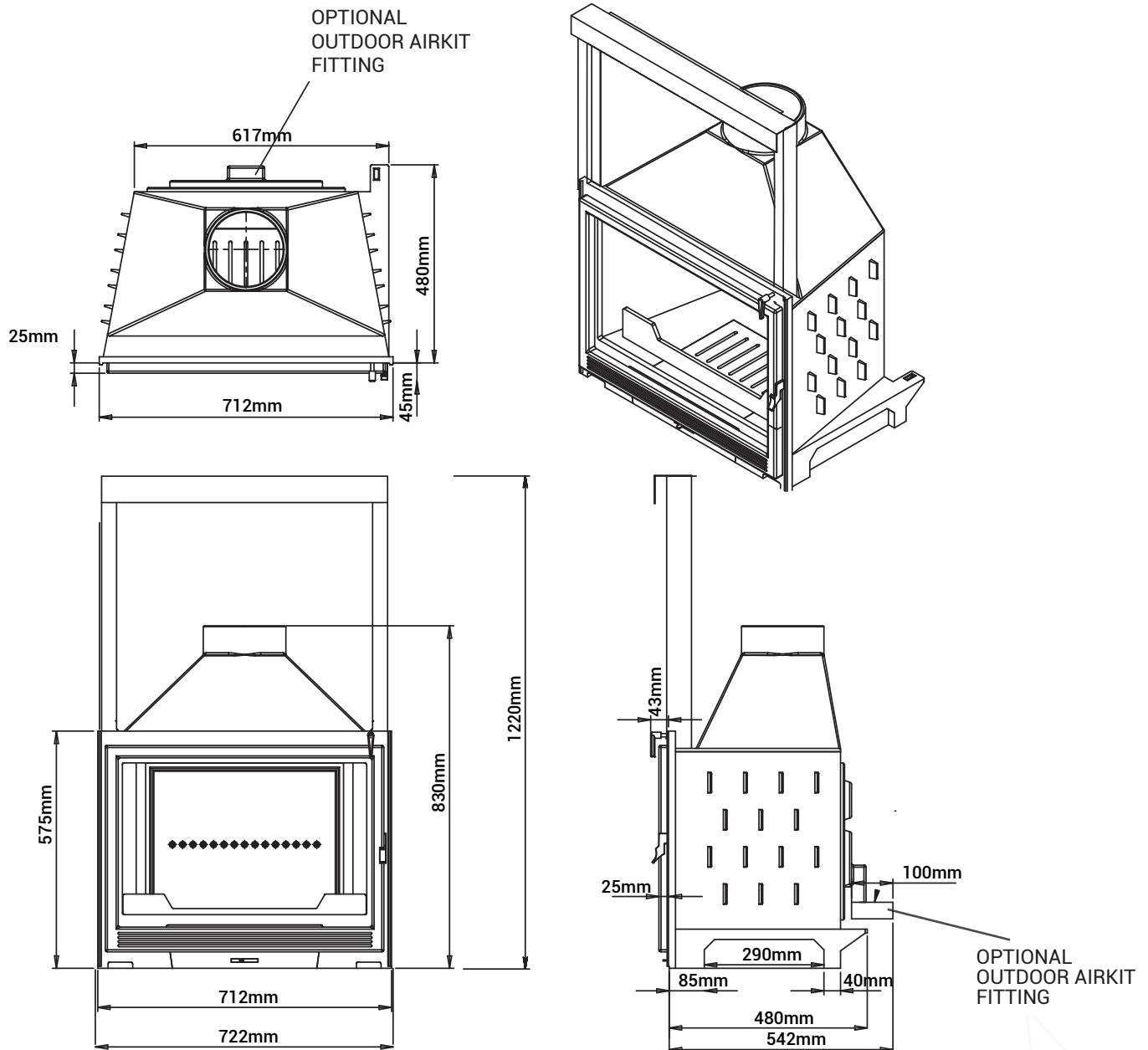

*Heating capacity of the following appliances are a guide only and refers to areas with 2.4m ceilings and 6 or more star rated buildings. Heating output may vary depending on factors such as building characteristics, quality of insulation, type of firewood used and climate zone.

** See warranty pg. 48 of the manual

*** For inbuilt models only

SEGUIN EUROPA 7 VL

MATERIAL	100% Pure cast iron, 8-12mm thickness
KW OUTPUT	17.9kW
HEATING CAPACITY	Up to 150-200m ² *
FACADE	Clean frame-less design (trim options available)
GLASS DOOR	Secure swing or lift up door opening system
MINIMUM FLUE HEIGHT	4.5m
FLUE SIZES	200mm, 250mm, 300mm
INCLUDES HOT AIR KIT	A duct and a register
OUTSIDE AIR KIT	Recommended for well insulated homes
WARRANTY	10 year firebox warranty**
WEIGHT	170kg
HEARTH DIMENSIONS	Min 500mm in front of any part of fireplace, 250mm on either side & 75mm thick***

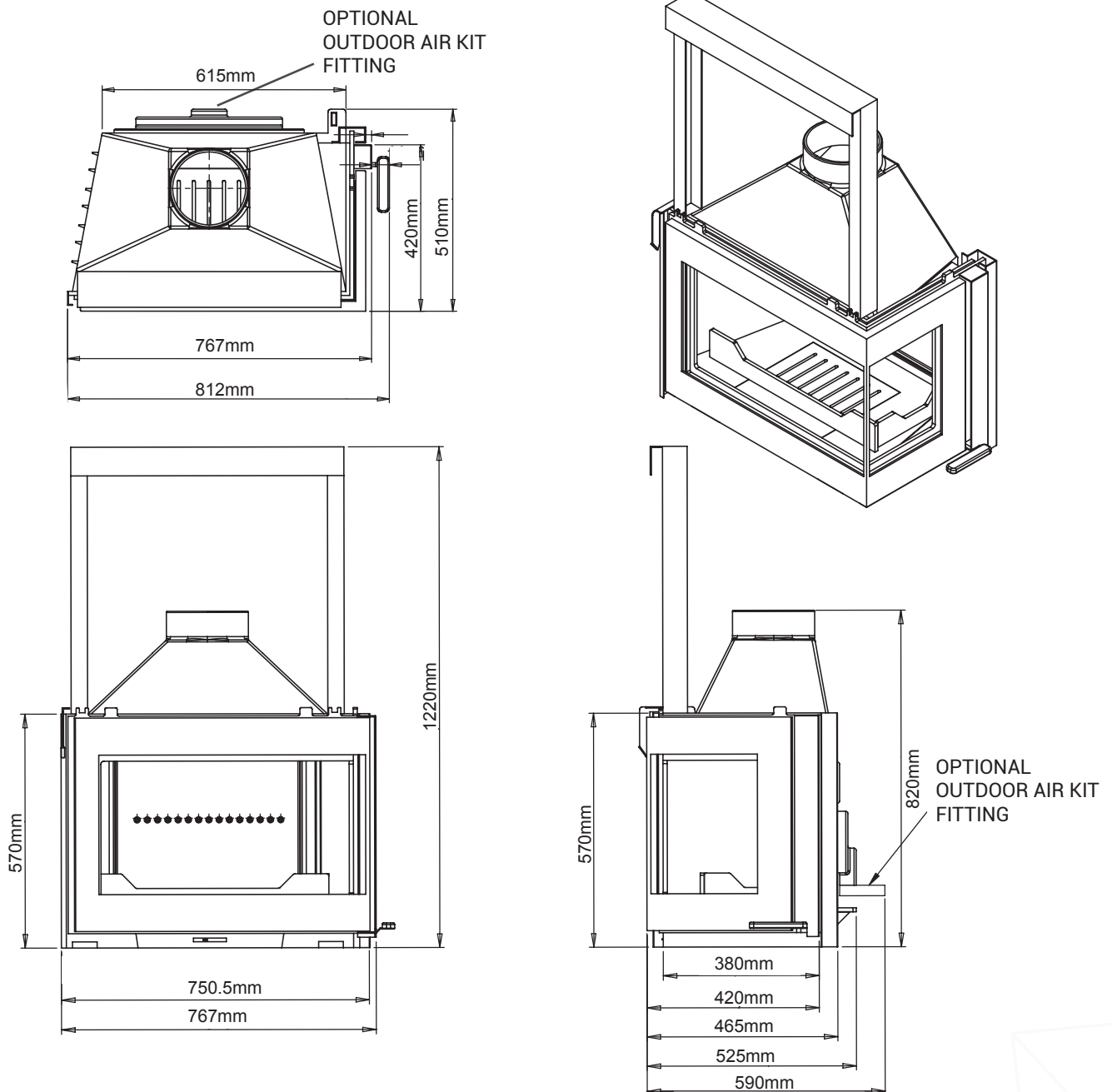

*Heating capacity of the following appliances are a guide only and refers to areas with 2.4m ceilings and 6 or more star rated buildings. Heating output may vary depending on factors such as building characteristics, quality of insulation, type of firewood used and climate zone.

** See warranty pg. 48 of the manual

*** For inbuilt models only

SEGUIN VISIO 8

MATERIAL	100% Pure cast iron, 8-12mm thickness
KW OUTPUT	27.8kW
HEATING CAPACITY	Up to 240-340m ² *
FACADE	Clean frame-less design (trim options available)
GLASS DOOR	Secure swing or lift up door opening system
MINIMUM FLUE HEIGHT	4.5m
FLUE SIZES	200mm, 250mm, 300mm
INCLUDES HOT AIR KIT	A duct and a register
OUTSIDE AIR KIT	Recommended for well insulated homes
WARRANTY	10 year firebox warranty*
WEIGHT	190kg
HEARTH DIMENSIONS	Min 500mm in front of any part of fireplace, 250mm on either side & 75mm thick***

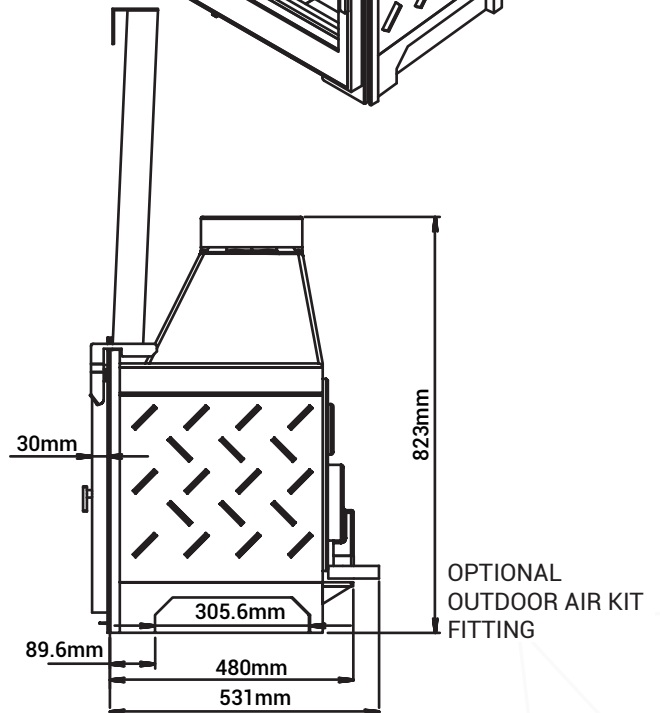
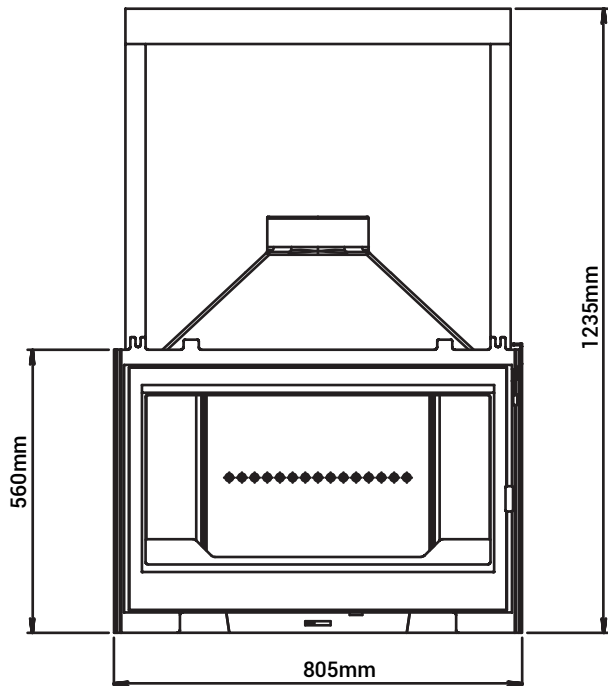
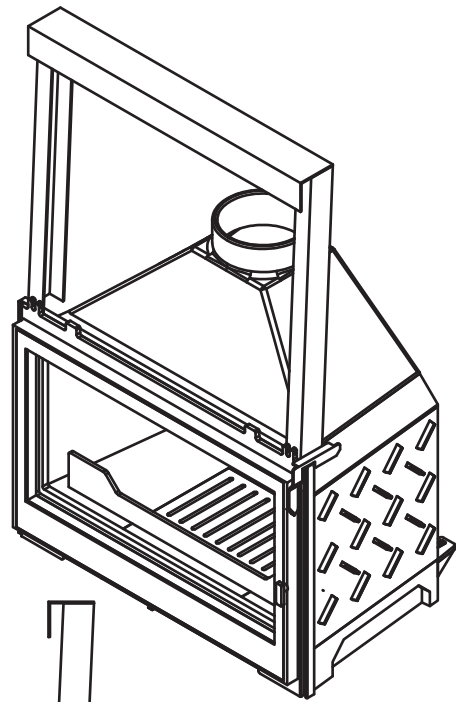
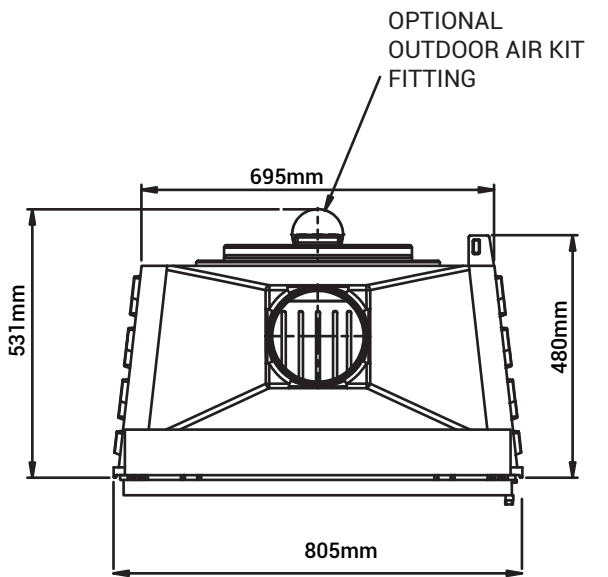

*Heating capacity of the following appliances are a guide only and refers to areas with 2.4m ceilings and 6 or more star rated buildings. Heating output may vary depending on factors such as building characteristics, quality of insulation, type of firewood used and climate zone.

** See warranty pg. 48 of the manual

*** For inbuilt models only

SEGUIN SUPER 9

MATERIAL	100% Pure cast iron, 8-12mm thickness
KW OUTPUT	26kW
HEATING CAPACITY	Up to 200-300m ² *
FACADE	Clean frame-less design (trim options available)
GLASS DOOR	Secure swing or lift up door opening system
MINIMUM FLUE HEIGHT	4.5m
FLUE SIZES	250mm, 300mm, 350mm
INCLUDES HOT AIR KIT	A duct and a register
OUTSIDE AIR KIT	Recommended for well insulated homes
WARRANTY	10 year firebox warranty**
WEIGHT	250kg
HEARTH DIMENSIONS	Min 500mm in front of any part of fireplace, 250mm on either side & 75mm thick***

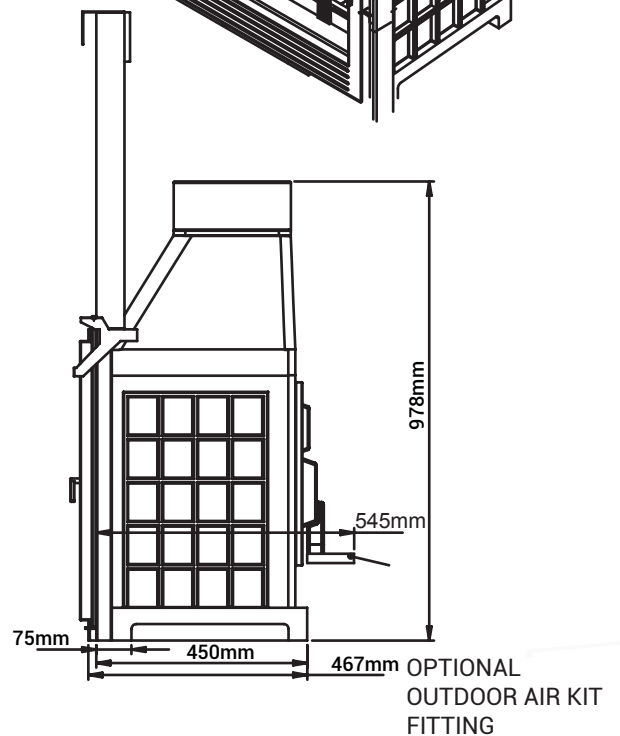
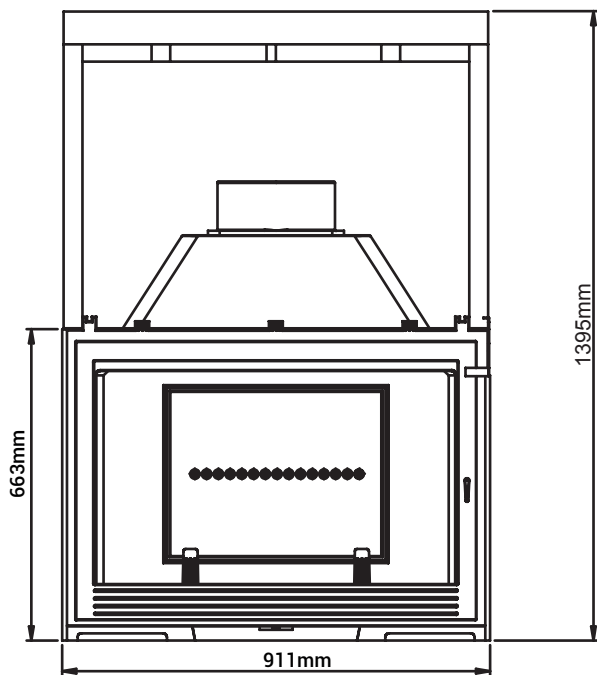
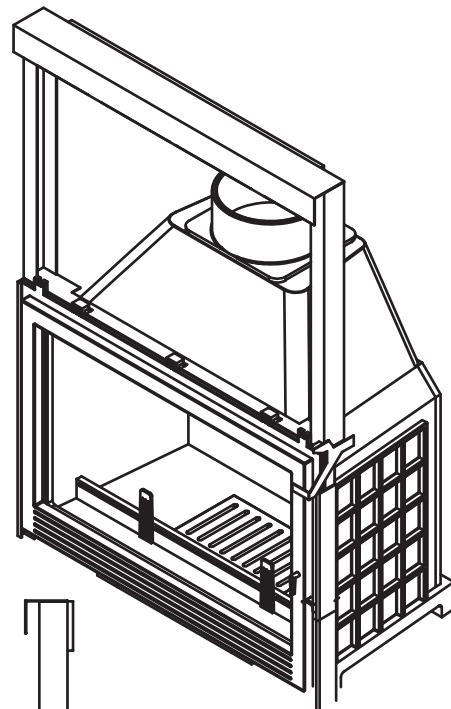
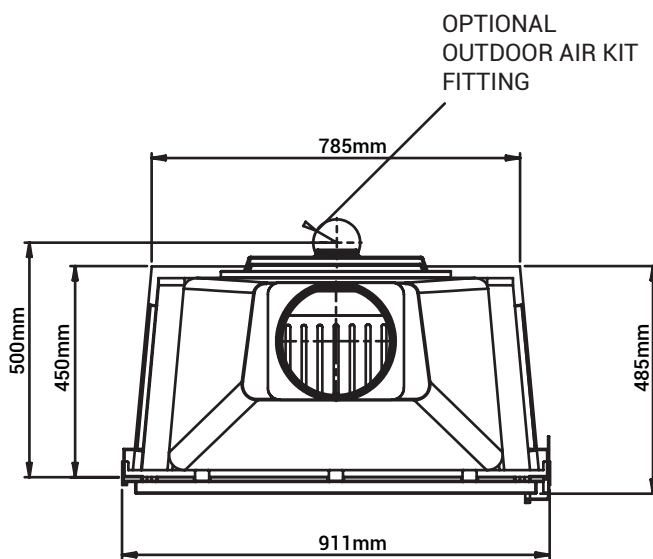

*Heating capacity of the following appliances are a guide only and refers to areas with 2.4m ceilings and 6 or more star rated buildings. Heating output may vary depending on factors such as building characteristics, quality of insulation, type of firewood used and climate zone.

** See warranty pg. 48 of the manual

*** For inbuilt models only

SEGUIN MULTIVISION 8000 SERIES

MATERIAL	100% Pure cast iron, 8-12mm thickness
KW OUTPUT	25.9kW* Single sided model
HEATING CAPACITY	Up to 150-200m ² *
FACADE	Clean frame-less design (trim options available)
GLASS DOOR	Secure swing or lift up door opening system (one side only)
MINIMUM FLUE HEIGHT	4.5m
FLUE SIZES	250mm, 300mm, 350mm
INCLUDES HOT AIR KIT	A duct and a register
OUTSIDE AIR KIT	Recommended for well insulated homes. Custom air kit required for this model (no direct connection)*
WARRANTY	10 year firebox warranty**
WEIGHT	230kg
HEARTH DIMENSIONS	Min 500mm in front of any part of fireplace, 250mm on either side & 75mm thick***

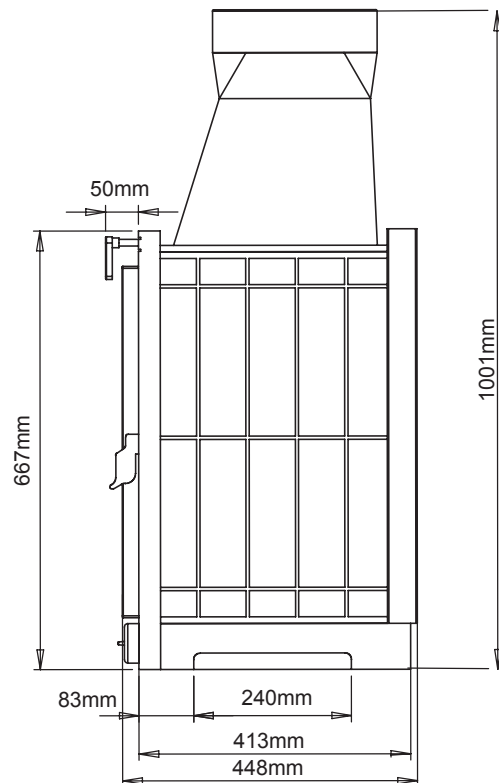
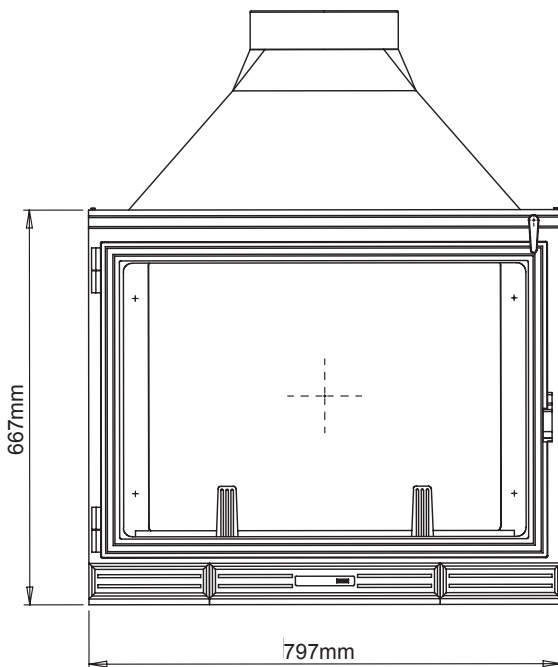
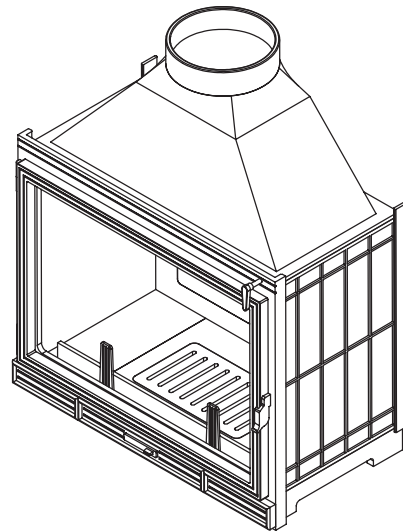
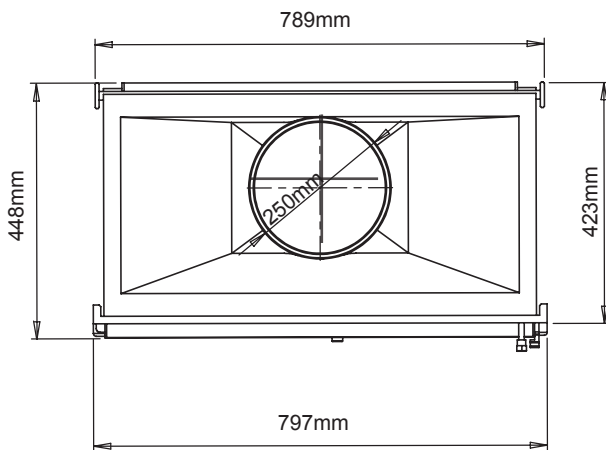

*Heating capacity of the following appliances are a guide only and refers to areas with 2.4m ceilings and 6 or more star rated buildings. Heating output may vary depending on factors such as building characteristics, quality of insulation, type of firewood used and climate zone.

** See warranty pg. 48 of the manual

*** For inbuilt models only

It is the users duty to make themselves aware of and apply all national or more restrictive local standards and instructions (AS/NZS 2918:2018).

IMPORTANT

Prior to unpacking and installation check that the appliance has not been damaged during transport. Ensure you check the glass, the door(s), the damper operation and the door locking mechanism

Before any work is carried out, as per local and national regulations and laws, this appliance MUST be installed by a licensed professional as per Australian and New Zealand Standards 2918:2018

IMPORTANT WARNING

It is strictly forbidden to use any combustible materials (ie; wooden framing, plaster, etc) near or around this appliance. Any exception from this rule is a health and safety hazard which will result in a non-compliant installation and a void of warranties.

Electrical cables and components must not be placed in the vicinity of the appliance as it is a fire hazard.

PRELIMINARY INSTALL INFORMATION

For the installation and use of this appliance, the fitter and the user should strictly adhere to local and national regulations in addition to Australian & New Zealand Standards AS/NZS 2918:2018. The installer should comply with the instructions and recommendations detailed in this manual. Safety and operation of the fireplace is directly dependent thereon. The liability of the manufacturer can neither be retained nor assured following failure of installation or incorrect use which does not comply with AS/NZS 2918:2018.

As each installation is unique, a qualified and licensed trades professional should take all required preliminary precautions depending on the technical elements inherent to each job.

In-observance of the assembly instructions in conjunction with AS/NZS 2918:2018 entails the liability of the person who carries it out.

As a result of faulty assembly, irrational use of parts or additional components that were not supplied by the manufacturer, and/or modifying of the appliance or components will result in inferior or unsafe operation. Should this occur the manufacturer bears no liability, and will result in a null and void product warranty.

PLEASE READ PRIOR TO INSTALL

All images and diagrams in this manual are for installation reference purposes only and are not to scale, the distributor and manufacturer bears no accuracy of these images and accepts no liability. The purpose of these images and diagrams is to act as a guide in conjunction with the written components, and are NOT to be used to instruct independently. The order of steps listed in this manual are recommendation only.

It is strongly recommended that the licensed trade professional who is performing the installation of this appliance, completely read and comprehend all instructions in this manual prior to proceeding. **Sculpt Fireplaces & Seguin Duteriez reserves the right to change these specifications without prior notice.**

For reasons of quality control, some of our appliances are delivered assembled. Some lighter units are directly assembled, puttied and sealed. Whilst other heavier models are delivered with the gasket unassembled to make it easier for transportation. Gasket and refractory putty is provided with these units, a slip is placed in all the non-jointed fireplace in order to attract attention. Assemble the gasket on the top of the firebox, the putty should be widely spread and then wiped.

ACCEPTABLE VARIANCE ALLOWANCE

Due to the production of these hand assembled and manufactured fireplaces, there is an acceptable allowance of 3-5mm variance of the unit, including the door frame. This variance in production is non-claimable under any warranties.

HEAT RESISTANT MATERIALS

Heat resistant materials must meet AS/NZS 2918:2018 clause 1.4.27 a material with an allowable service temperature of 600° Celsius or greater.

EXPOSURE TO ELEMENTS

Axis fireplaces are exclusively designed as indoor heating appliances, should the fireplace (or part there of) be in contact with the outside elements including rain, snow, direct sunlight, excessive winds, etc. Then the damage sustained thereon will not be covered under the manufacturer or distributor warrantie(s). Please consider prior to installing your fireplace exposed to outside elements.

PLEASE READ PRIOR TO INSTALL

The diagrams depicted in this manual feature the installation procedure for the Seguin Super 9, while this may not be the same unit as your appliance, the process of the installation procedure across the range is standardised & should be adapted to suit your unit requirements. Depending on your appliance and installation scenario elements may vary including frame, cavity and dimensions.

No two installation follows the exact same procedure, as no two homes are alike, it is important to work with your professional installer, architect and builder to structure a custom installation that suits your scenario. Further questions regarding your appliance and its installation should be directed towards your supplier.

All images and diagrams in this manual are for installation reference purposes only and are not to scale. The distributor and manufacturer bears no accuracy of these images and accepts no liability. The purpose of these images and diagrams is to act as a guide in conjunction with the written components and are NOT to instruct independently. The order of these steps are a recommendation only.

It is strongly recommended that the licensed trade professional who is performing the installation of this appliance, completely read and understand all instructions in this manual prior to proceeding.

Sculpt Fireplaces & Seguin reserves the right to change these specifications without prior notice.

IMPORTANT: For possibly replacing the flue or for a technical intervention, the installation of an access hatch on the fireplace cavity is highly recommended.

ACCESS HATCH:

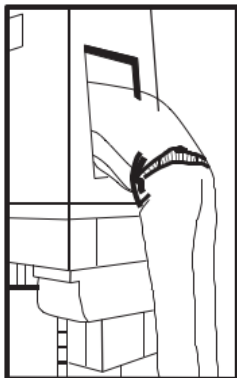

PLEASE READ PRIOR TO INSTALL**FRESH AIR INLET, RECOMMENDED FOR ALL INSTALLATIONS**

The air inlet is recommended for installation and is essential for the proper function of the appliance. The fresh combustion air inlet must be a minimum 300cm² and ideally positioned (see point A & B on diagram).

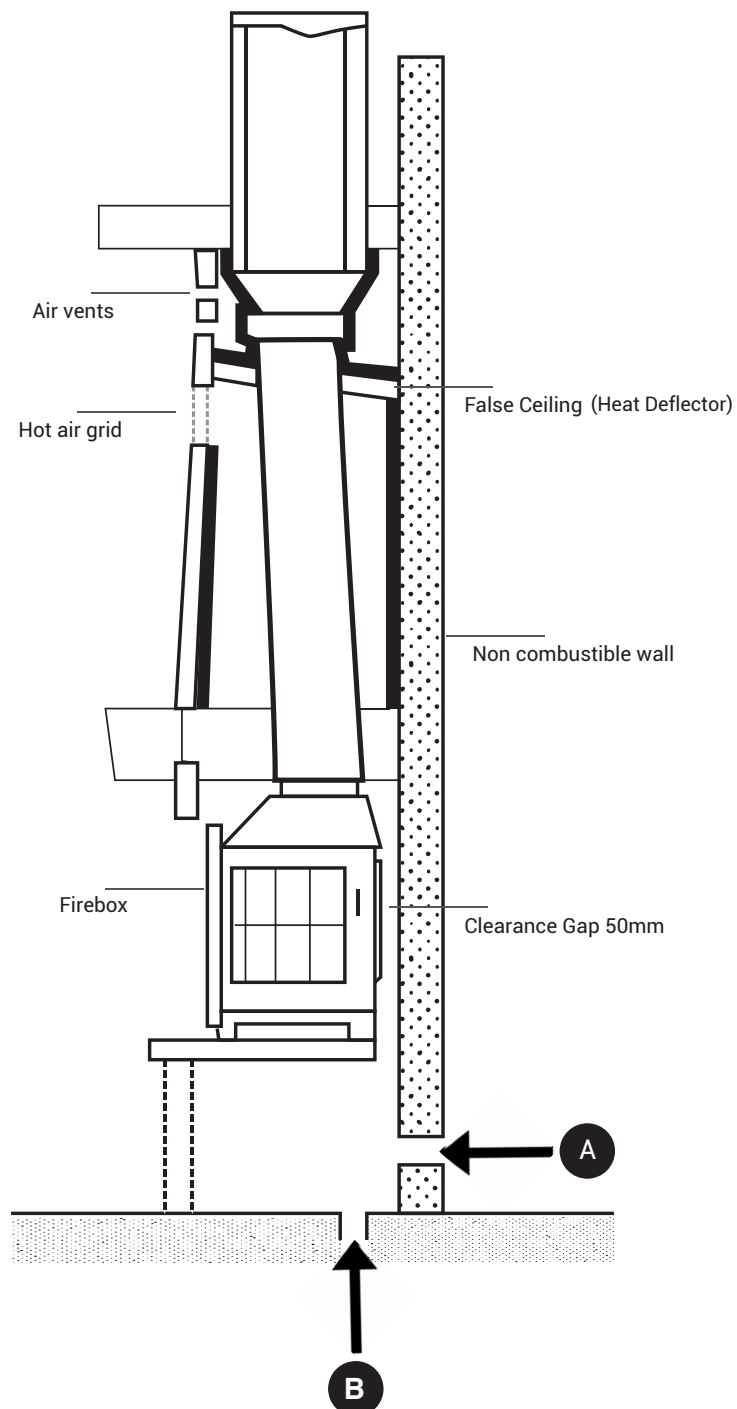

IMPORTANT

This components list details the number of flue supplied (by the retailer) according to unit and minimum flue kit requirements. For correct use please ensure you are referring to your unit model and installation kit type. For any questions in relation to the supplied components contact your local retailer. Each unit is supplied with a ducting kit consisting of; one metal register and one duct (4 Zero Type: aluminium inner core, aluminium outer, poly insulated, minimum R1.0) by the retailer.

4.5M INBUILT TRIPLE SKIN FLUE KIT - SEGUIN EUROPA 7 & VISIO 8

QUANTITY	COMPONENTS
5	900MM STAINLESS FLUE - 200MM DIAMETER
4	900MM GALVANISED FLUE - 250MM DIAMETER
4	900MM GALVANISED FLUE - 300MM DIAMETER
1	WIND RIM COWL TO SUIT

4.5M INBUILT TRIPLE SKIN FLUE KIT - SEGUIN SUPER 9

QUANTITY	COMPONENTS
5	900MM STAINLESS FLUE - 250MM DIAMETER
4	900MM GALVANISED FLUE - 300MM DIAMETER
4	900MM GALVANISED FLUE - 350MM DIAMETER
1	WIND RIM COWL TO SUIT

4.5M INBUILT CHIMNEY FLUE KIT - SEGUIN EUROPA 7 & VISIO 8 PLUS

QUANTITY	COMPONENTS
5	900MM STAINLESS FLUE - 200MM DIAMETER
1	900MM GALVANISED FLUE - 300MM DIAMETER
1	WIND RIM COWL TO SUIT

Sculpt Fireplace Collection bears no liability to the functioning and supply of these components. Additional components required for installation are the responsibility of the retailer and (or) installer.

4.5M INBUILT CHIMNEY FLUE KIT - SEGUIN SUPER 9

QUANTITY	COMPONENTS
5	900MM STAINLESS FLUE - 250MM DIAMETER
1	900MM GALVANISED FLUE - 300MM DIAMETER
	WIND RIM OPTION B COWL TO SUIT

4.5M FREESTANDING BLACK FLUE KIT - SEGUIN EUROPA 7 & VISIO 8 PLUS

QUANTITY	COMPONENTS
5	900MM STAINLESS FLUE - 200MM DIAMETER
3*	900MM BLACK GALVANISED FLUE - 250MM DIAMETER
2	900MM GALVANISED FLUE - 250MM DIAMETER
2	900MM GALVANISED FLUE - 300MM DIAMETER
1	BLACK DROPPER BOX AND CEILING RING TO SUIT
1	WIND RIM OPTION B COWL

4.5M FREE STANDING BLACK FLUE KIT - SEGUIN SUPER 9

QUANTITY	COMPONENTS
5	900MM STAINLESS FLUE - 250MM DIAMETER
3*	900MM BLACK GALVANISED FLUE - 300MM DIAMETER
2	900MM GALVANISED FLUE - 300MM DIAMETER
2	900MM GALVANISED FLUE - 350MM DIAMETER
1	BLACK DROPPER BOX AND CEILING RING TO SUIT
1	WIND RIM OPTION B COWL

*Double skin black flue to be dependant on ceiling height, ascertained by the retailer.



STEP 1: BASE

Lay a masonry base, minimum 75mm thick (ie. Solid bricks). The base should be laid on an adequate ground capable of supporting its weight.

****IMPORTANT****

If using the optional Outdoor Air Kit please leave a 125mm air gap behind the firebox. Refer to Step 6: Outdoor Air Kit.



STEP 2: BACK WALL

Using masonry brick, construct the back wall from the base to the top of the ceiling.



STEP 3: SHEET METAL LAYER (OPTIONAL STEP)

Place a thin piece of sheet metal on top of the bricks in order to level the base and safely manoeuvre the firebox.

Allow a minimum of 100mm on all sides.

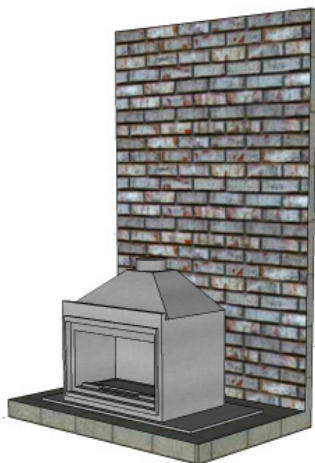

STEP 4: POSITIONING OF THE UNIT

Place the firebox into position on top of the sheet metal. Remember to leave a 25mm air gap on all sides of the firebox. (If an outdoor air-kit is to be connected please leave a 125mm air-gap at the rear of the firebox).

STEP 5: LIFT UP DOOR ASSEMBLY (IF NOT REQUIRED GO TO STEP 6)

****IMPORTANT****

Refer to images on page 38. LIFT UP DOOR ASSEMBLY.

Three bolts mount the lift up door mechanism. It is recommended that you use two solid pieces of timber approximately 450mm long in order to assist in the assembly of the door.

1. Lift the door into position and place door lift mechanism in position above fireplace door.
2. Lift ballast and place timbers in-between guillotine movement of slider to prevent ballast from coming back down.
3. Fix the 3 silver bolts into the heater frame through the ballast frame
4. Release weight from the wood when mechanism is secure in place.
5. Lift ballast and secure chains through sprocket onto the small bolts attached to door (make sure spacers for chain are inserted into link attached to door)
6. Release weight from the wood when chain is secured on both sides of door.

Door should now lift and lower with ease, please test this before continuing.

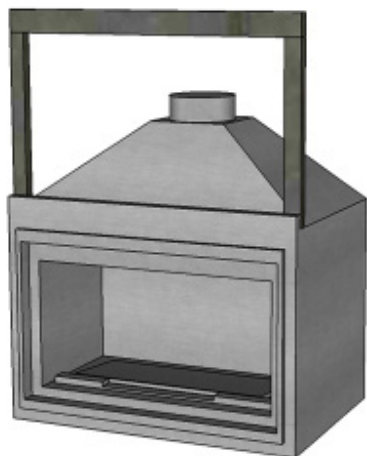

STEP 6: OUTDOOR AIR KIT (IF NOT REQUIRED GO TO STEP 7)

Any depression or lack of fresh air within the room where the fireplace is located can result in emanation of smoke to flow back into the room and for the unit to run inefficiently. It is highly recommended that an Outdoor Air Kit be installed in 6 star or more rated homes, or any install where a mechanical device (ie. fan), takes air from the fireplace cavity & transfers it.

Place the adaptor on the back of the unit and screw into position. Attach the flexi flue to the adaptor and run to the external brick wall at the rear of the unit, proceed to connect the metal vermin proof cowl onto the outside wall.

The flexi flue can be positioned either side of the adaptor in order to fit between the heater and the wall. It is not required that the flexi flue be positioned directly behind the firebox.

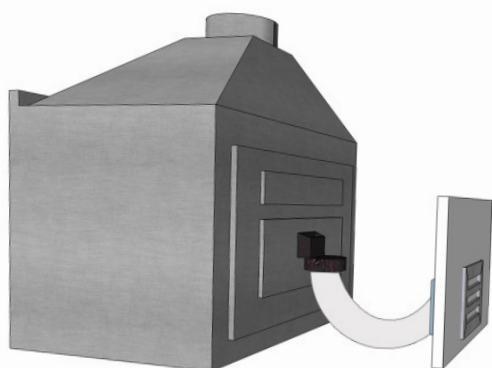

STEP 7: LAYLA 3 TRIM WITH LIFT DOOR (IF NOT REQUIRED GO TO STEP 8)

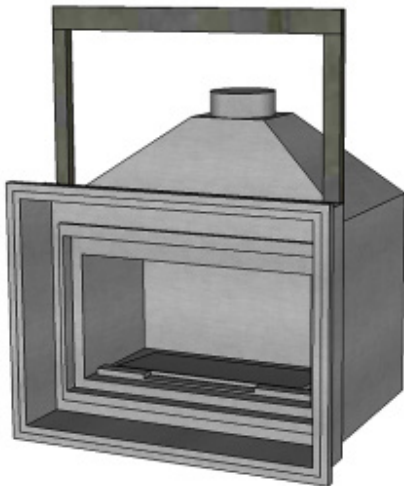

****IMPORTANT****

Trim must be fitted onto the firebox PRIOR to installing the front of the masonry enclosure.

1. Put the trim on the front of the firebox
2. On the side of the façade of the firebox drill two holes at 4.2mm
3. The holes must match with the slotted holes on the trim
4. Put the trim into place
5. Fix the trim with the screws provided (screws M5 + washers)

LAYLA 3 TRIM WITH NO LIFT DOOR (IF NOT REQUIRED GO TO STEP 8)

If the trim is to be assembled to fit onto a firebox not equipped with a lift up door, you will need to weld the bracket (width 5 mm each). The brackets (2x5 mm) are necessary to compensate the initial width of the trim.

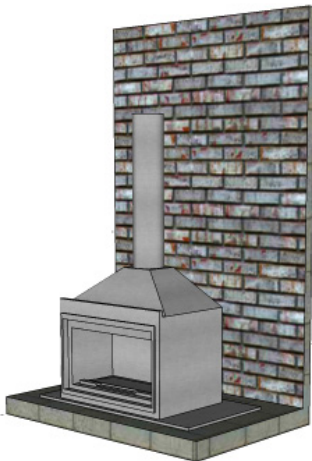

STEP 8: FIRST LENGTH OF FLUE

Place the first single skin length of flue (with no crimp ends) around the outside of the spigot. You may also use a heat resistance sealant (i.e. Firecork) to seal any air gaps. Before installing the remaining lengths of flue please continue to the next step.

STEP 9: SIDE WALLS & VENTILATION

****IMPORTANT****

Ventilation is required on the enclosure to assist with air circulation. A minimum of two air intake grills are required at the bottom and a minimum of two air out-take grills are required on top of the masonry enclosure (2X inflow 2X outflow). All vents can be positioned either side OR the front of the masonry enclosure. ALL vents must adhere to the minimum vent size of size 300cm².

Using masonry (ie. clay bricks) build a layer of bricks from the base to the top of the ceiling on either side of the firebox. Remember to leave a minimum 25mm air gap on all edges.

***The vent sizes and quantity can be adapted and changed BUT they must meet the minimum ventilation requirements as specified above. For custom made vents please contact your nearest dealer. ALL VENTS MUST NOT BE PLASTIC OR COMBUSTIBLE.**

***All air vents must have a minimum clearance to combustibles of 600mm in front and 300mm above the metal vent itself.**

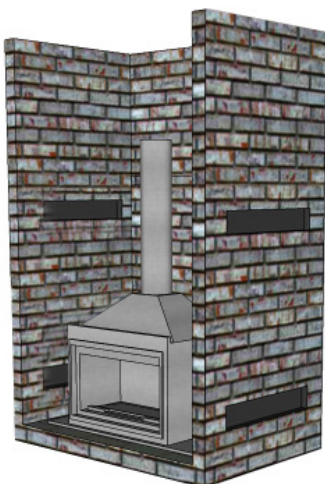

STEP 10: CAVITY LID

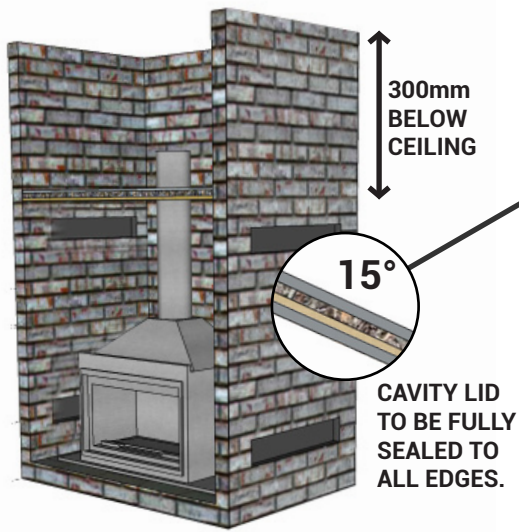

****IMPORTANT****

SIDE VENTS

It is highly recommended the cavity lid be installed flat to ensure sufficient air flow around the appliance if 2 vents are used.

FRONT VENTS

It is highly recommended the cavity lid be installed on an angle of 15° facing the front of the fireplace to ensure sufficient air flow around the appliance.

The cavity lid must be installed 300mm below the ceiling and is comprised of the following; minimum 0.5mm thick steel plate for support, followed by a 12mm thick heat resistant sheet, with 1 x 25mm Rockwool sheet. A hole is to be cut in the centre of the lid in order for the single skin flue to penetrate through tightly. You may also use a heat resistance sealant (i.e. Firecork) and heat proof tape to seal any air gaps. **Please ensure the cavity lid is fully sealed to all edges.**

STEP 11: DUCTING

The duct MUST be 4 Zero type (aluminium inner core, aluminium outer, poly insulated, minimum RI.0) and tested to AS 4254.1-2012. Outlet MUST be metal.

This unit has been supplied with a ducting kit by the retailer (consisting of one duct and one metal register), while it is highly recommended that it be installed, if not installed it will have no implication on the functioning of the unit.

Cut a hole in the lid of the enclosure nearest to the room where the heat is to be transferred. Run the ducting from this hole into the roof space and locate to the room, cut out the plaster and install a metal register into the ceiling of the next room.

****PLEASE NOTE: A maximum duct run of 6m is recommended, no more than two ducts should run off this cavity.**

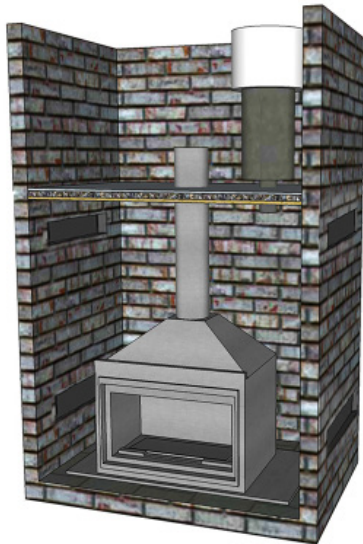

FAN MUST BE METAL NOT PLASTIC

STEP 12: FLUE INSTALLATION

Triple skin flue is to then be continued on top of the cavity lid. The lower end of the triple skin casing shall be close fitting against the lid and the outer casing must be ventilated. Air vents on the first length of triple skin flue must be cut (please use diagram as a guide), or manufactured into the bottom length of the flue.

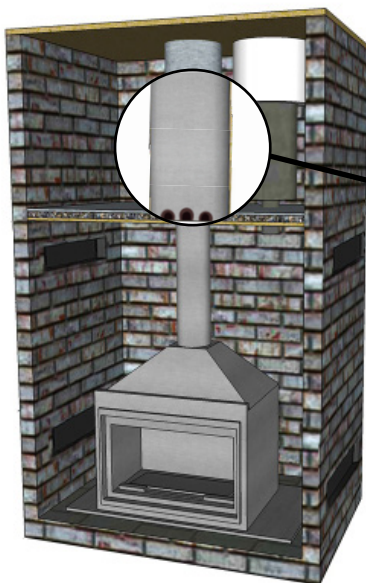



STEP 13: FLUE INSTALLATION

The triple skin flue will then be continued into the roof cavity and above the roof line, as per Australian & New Zealand Standard AS/NZ 2918:2018. There must be a 25mm clearance around the outer triple skin flue. The flue must extend a minimum 1m above the roof line and have a 3m diameter clearance from the top of the cowl to any objects in a horizontal direction.

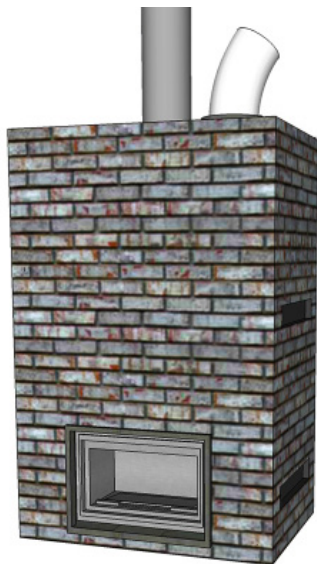

STEP 14: FRONT OF THE ENCLOSURE

The front of the enclosure can now be fitted with masonry bricks, or a layer of 12mm minimum thick heat resistant sheet. Remember to keep an air gap of 25mm from the front of the unit.

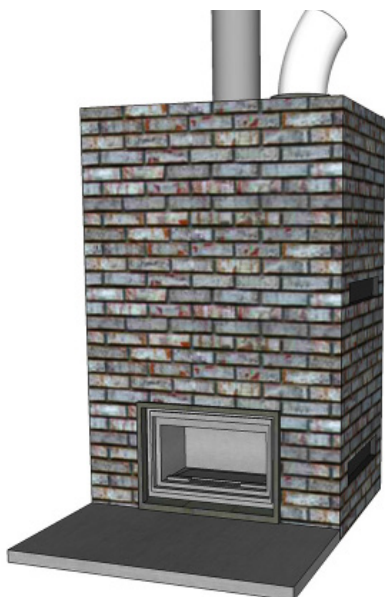

STEP 15: HEARTH (FLOOR PROTECTOR)

The hearth must be constructed from masonry or a non combustible material and must extend 500mm in front of the appliance, 250mm on either side of the appliance and have a thickness of 75mm.



STEP 16: BAFFLE PLATE

Ensuring the wider end of the baffle plate is facing the inside back wall of the firebox, and the flat surfaces are positioned downwards, proceed to gently position the plate on the lugs located on the inside ceiling of the firebox. Once in position ensure the plate sits securely, the baffle plate should not rock or shift when touched if placed correctly.



STEP 1: BASE

Lay a masonry base, minimum 75mm thick (ie. solid bricks). The base should be laid on an adequate ground capable of supporting its weight.

****IMPORTANT****

If using the optional Outdoor Air Kit please leave a 125mm air gap behind the firebox. Refer to Step 6: Outdoor Air Kit.



STEP 2: BACK WALL & METAL SHEET (OPTIONAL STEP)

Using Hebel, build the back wall from the base to the top of the ceiling.

Place a piece of sheet metal on top of the masonry base, this will level the base and enable you to safely manoeuvre the firebox.

Allow a minimum of 100mm clearance on all sides.

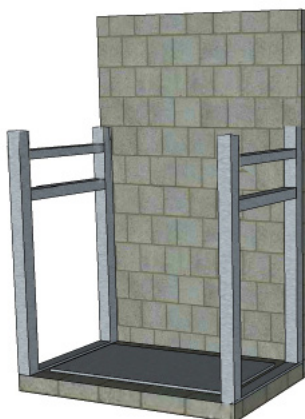

STEP 3: STEEL FRAME

Place a steel frame (minimum 51mm thick) on either side of the enclosure. Remember to leave a 100mm air gap on the sides of the appliance.

****IMPORTANT****

It is strongly recommended that the steel frame allows for a distance of 300mm to the ceiling, this allows the cavity lid to be placed directly above and stop heat from travelling above the lid via the frame.

STEP 4: SIDE WALLS - SECOND LAYER & VENTILATION

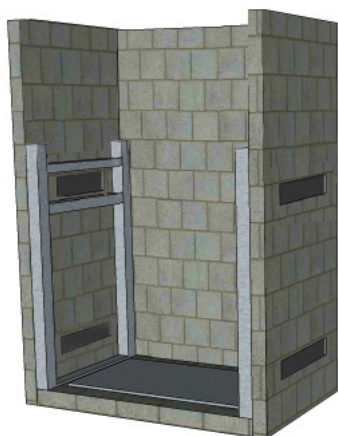

****IMPORTANT****

Ventilation is required on the enclosure to help with air circulation. A minimum of two air intake grills are required at the bottom and a minimum of two air out-take grills are required on top of the masonry enclosure (2X inflow 2X outflow). All vents can be positioned either side OR the front of the masonry enclosure. ALL vents must adhere to the minimum vent size of size 300cm².

*The vent sizes and quantity can be adapted and changed BUT they must meet the minimum ventilation requirements as specified above. For custom made vents please contact your nearest dealer. ALL VENTS MUST NOT BE PLASTIC OR COMBUSTIBLE.

Using Hebel build a layer of bricks from the base to the top of the ceiling on either side of the enclosure.

*All air-vents must have a minimum clearance to combustibles of 600mm in front and 300mm above the metal vent itself.

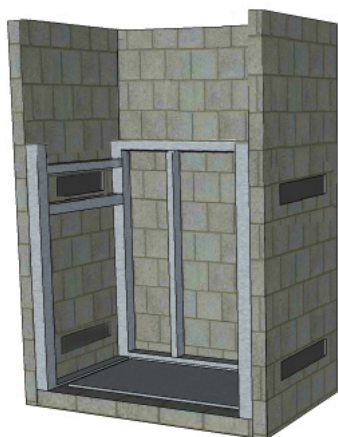

STEP 5: BACK WALL COMPLETION

For structural support place a steel frame on the back wall in front of the Hebel and connect to the two opposing steel frames.

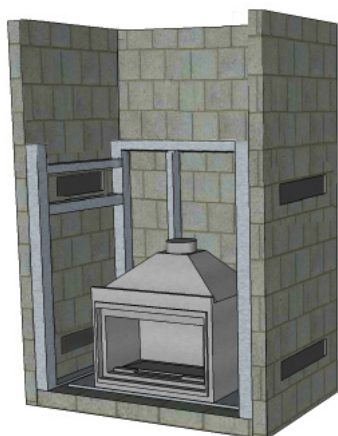

STEP 6: POSITIONING OF THE UNIT

Place the firebox into position on top of the sheet metal. Remember to leave a 100mm air gap on all sides of the firebox. (If an outdoor air-kit is to be connected please leave a 125mm air-gap at the rear of the firebox).

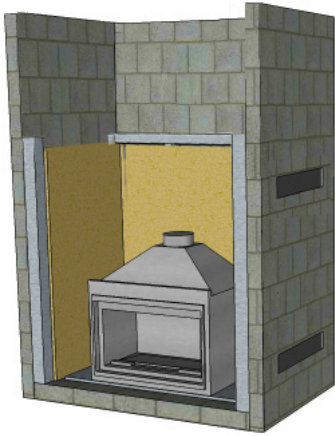

STEP 7: SIDE WALLS - FINAL LAYER

Using recommended Fibretex 650 Rockwool (minimum 30mm thick) place a layer on each inside wall panel.

STEP 8: LIFT UP DOOR ASSEMBLY (IF NOT REQUIRED GO TO STEP 9)

****IMPORTANT****

Refer to images on page 38. LIFT UP DOOR ASSEMBLY.

Three bolts mount the lift up door mechanism. It is recommended that you use two solid pieces of timber approximately 450mm long in order to assist in the assembly of the door.

1. Lift the door into position and place door lift mechanism in position above fireplace door.
2. Lift ballast and place timbers in-between guillotine movement of slider to prevent ballast from coming back down.
3. Fix the 3 silver bolts into the heater frame through the ballast frame
4. Release weight from the wood when mechanism is secure in place.
5. Lift ballast and secure chains through sprocket onto the small bolts attached to door (make sure spacers for chain are inserted into link attached to door)
6. Release weight from the wood when chain is secured on both sides of door.

Door should now lift and lower with ease, please test this before continuing.

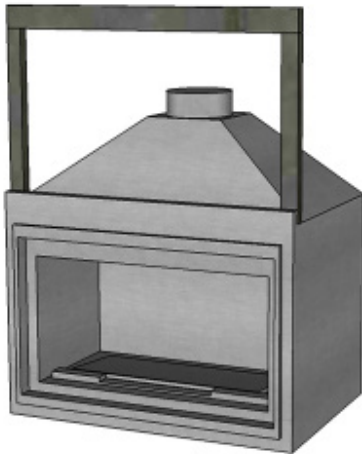

STEP 9: OUTDOOR AIR KIT (IF NOT REQUIRED GO TO STEP 10)

Any depression or lack of fresh air within the room where the fireplace is located can cause emanation of smoke to flow back into the room and the unit to run inefficiently. It is highly recommended that an Outdoor Air Kit be installed in six or more star rated homes, or any install where a mechanical device (ie. fan), takes air from the fireplace cavity & transfers it.

Place the adaptor on the back of the unit and screw into position. Attach the flexi flue to the adaptor and run to the external brick wall at the rear of the unit, then proceed to connect the metal vermin proof cowl onto the outside wall.

The flexi flue can be positioned either side of the adaptor in order to fit between the heater and the wall. It is not required that the flexi flue be positioned directly behind the firebox.

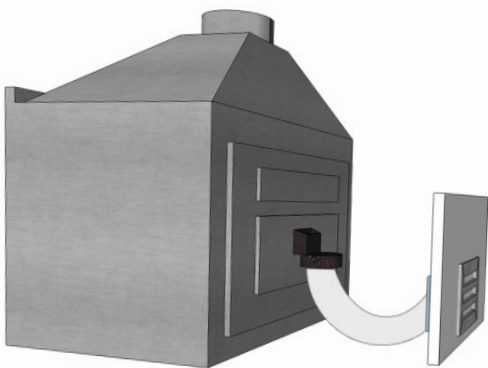

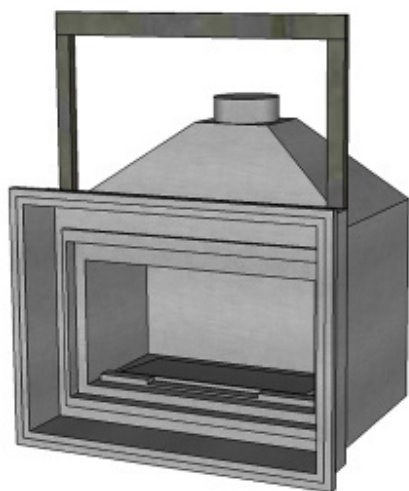

STEP 10: LAYLA 3 TRIM WITH LIFT DOOR (IF NOT REQUIRED GO TO STEP 11)

****IMPORTANT****

Trim must be fitted onto the firebox PRIOR to installing the front of the masonry enclosure.

1. Put the trim on the front of the firebox
2. On the side of the façade of the firebox drill two holes at 4.2mm
3. The holes must match with the slotted holes on the trim
4. Put the trim into place
5. Fix the trim with the screws provided (screws M5 + washers)

LAYLA 3 TRIM WITH NO LIFT DOOR

If the trim is to be assembled to fit onto a firebox not equipped with a lift up door, you will need to secure the bracket (width 5 mm each). The brackets (2x5 mm) are necessary to compensate the initial width of the trim.

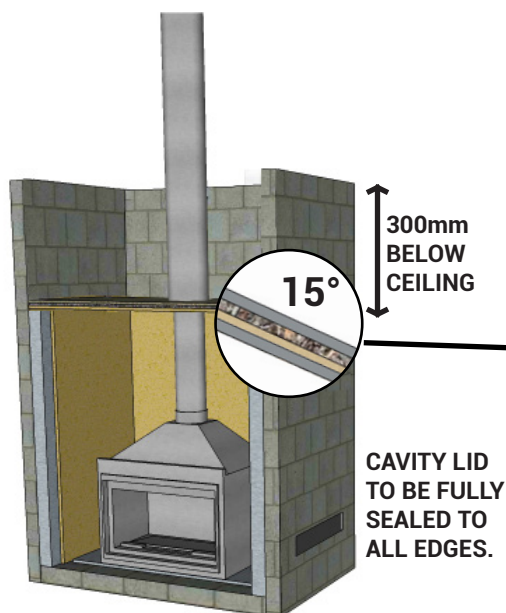

STEP 11: FIRST LENGTH OF FLUE & CAVITY LID

Place the first single skin length of flue (with no crimp ends) around the outside of the spigot. You may also use a heat resistance sealant (i.e. Firecork) to seal any air gaps. Before installing the remaining lengths of flue please go to the next step.

STEP 12: CAVITY LID

****IMPORTANT****

SIDE VENTS

It is highly recommended the cavity lid be installed flat to ensure sufficient air flow around the appliance.

FRONT VENTS

It is highly recommended the cavity lid be installed on an angle of 15° facing the front of the fireplace to ensure sufficient air flow around the appliance.

The cavity lid must be installed 300mm below the ceiling and is comprised of the following; minimum 0.5mm thick steel plate for support, followed by a 12mm thick heat resistant sheet, with 1 x 25mm Rockwool sheet. A hole is to be cut in the centre of the lid in order for the single skin flue to penetrate through tightly. You may also use a heat resistance sealant (i.e. Firecork) and heat proof tape to seal the any air gaps.
Please ensure the cavity lid is fully sealed to all edges.

STEP 13: FLUE INSTALLATION

Where the flue passes through the lid of the enclosure the flue shall be single skin, the triple skin flue must sit on top of lid of the enclosure. The lower end of the triple skin casing shall be close fitting against the lid and must be ventilated. The triple skin flue will then be continued into the roof cavity and above the roof line, as per Australian & New Zealand Standard AS/NZ 2918:2018. There must be a 25mm clearance around the outer triple skin flue, the flue must extend a minimum 1m above the roof line and have a 3m diameter clearance from the top of the cowl to any objects in a horizontal direction.



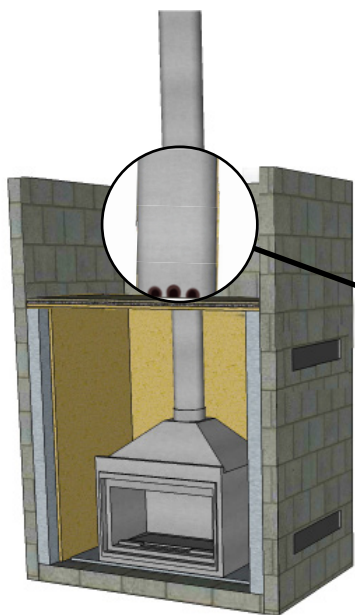

STEP 14: FLUE INSTALLATION

Triple skin flue is to then be continued on top of the cavity lid. The lower end of the middle skin casing shall be close fitting against the lid and the outer casing must be ventilated. Air vents on the first length of triple skin flue must be cut (please use diagram as a guide).

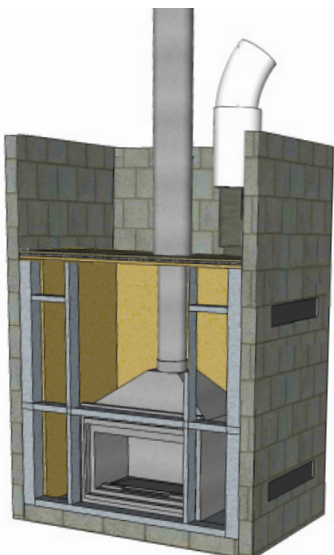

STEP 15: DUCTING

The duct **MUST** be 4 Zero type (aluminium inner core, aluminium outer, poly insulated, minimum R1.0) and tested to AS 4254.1-2012. Outlet **MUST** be metal.

This unit has been supplied with a ducting kit (consisting of one duct and one metal register), while it is highly recommended that it be installed, if not installed it will have no implication on the functioning of the unit.

Cut a hole in the lid of the enclosure nearest to the room where the heat is to be transferred. Run the ducting from this hole into the roof space and locate to the room, cut out the plaster and install a metal register into the ceiling of the next room.

****PLEASE NOTE: A maximum duct run of 6m is recommended, no more than two ducts can run off this cavity.**

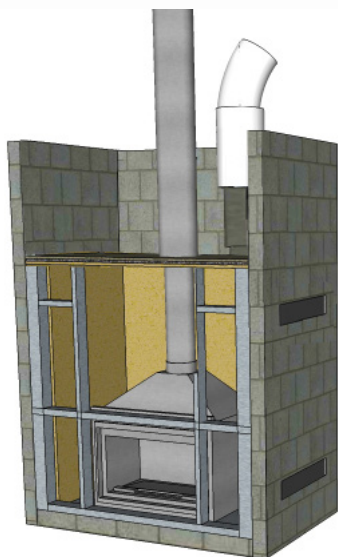

STEP 16: FRONT STEEL FRAME

Place a steel frame (minimum 51mm thick) to the front of the enclosure, ensuring a minimum 25mm clearance to the unit itself.

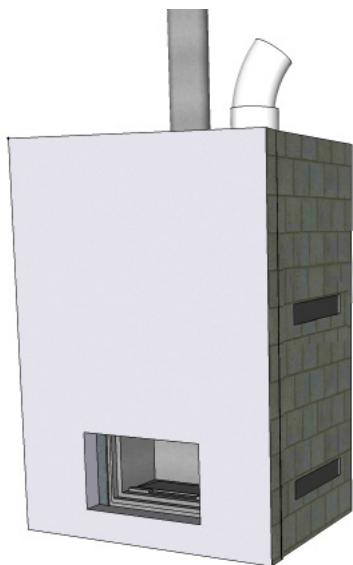

STEP 17: FRONT: FINAL LAYER

Place a layer of 12mm minimum thick heat resistant material on the exterior and finish. Place a sheet of rockwool on the inside face.

****IMPORTANT****

Do not use Fyrcek to finish the cavity exterior

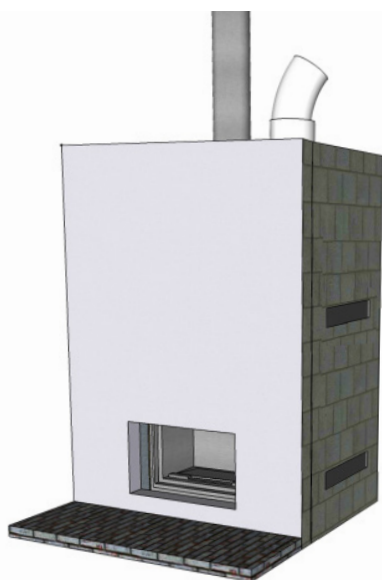

STEP 18: HEARTH (FLOOR PROTECTOR)

The hearth must be constructed from masonry or a non combustible material, and must extend 500mm in front of the appliance, 250mm on either side of the appliance and a thickness of 75mm.



STEP 19: BAFFLE PLATE

Ensuring the wider end of the baffle plate is facing the inside back wall of the firebox, and the flat surfaces are positioned downwards, proceed to gently position the plate on the lugs located on the inside ceiling of the firebox. Once in position ensure the plate sits securely, the baffle plate should not rock or shift when touched if placed correctly.

SKAMOTEC 225 is light weight material providing several advantages- excellent R-value, high mechanical strength, low thermal conductivity and maximum service temperatures of 1000 C°. The exceptional heat resistance makes the SKAMOTEC 225 able to withstand continuous heat cycles to full service temperature limit and the low thermal conductivity provides maximum insulation throughout the temperature range making it the ideal product when building custom fireplace enclosures.*

PLEASE REFER TO SKAMOTEC 225 INSTALLATION MANUAL

ONLINE VIDEO SKAMOTEC 225 - BUILDING BOARD FOR FIREPLACE ENCLOSURES (VISIT [YOUTUBE.COM](https://www.youtube.com))

PLEASE NOTE THAT A SKAMOTEC ENCLOSURE/CAVITY IS NOT CONSIDERED A MASONRY ENCLOSURE/CAVITY. PLEASE REFER TO AUSTRALIAN & NEW ZEALAND STANDARDS AS/NZS 2918/2014

SKAMOTEC can be purchased from any Sculpt Fireplace Collection retailer or installer.

*Referenced from skamol brochure "skamotec 225 building board for fireplace enclosures", all rights reserved.

STEP 1: BASE

Lay a masonry base, minimum 75mm thick (ie. Solid bricks). The base should be laid on an adequate ground capable of supporting its weight.

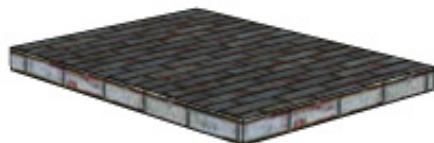

STEP 2: SHEET METAL LAYER (OPTIONAL STEP)

Place a piece of sheet metal on top of the masonry base, this will level the base and enable you to safely manoeuvre the firebox.

Allow a minimum of 100mm on all sides.

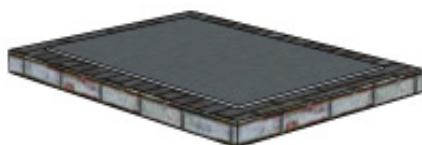

STEP 3: SIDE FRAMES

Place a steel frame (minimum 51mm thick) on either side of the enclosure. Remember to leave a 100mm air gap on the sides of the appliance.

****IMPORTANT****

It is strongly recommended that the steel frame allows for a distance of 300mm to the ceiling, this allows the cavity lid to be placed directly above and stop heat from travelling above the lid via the frame.

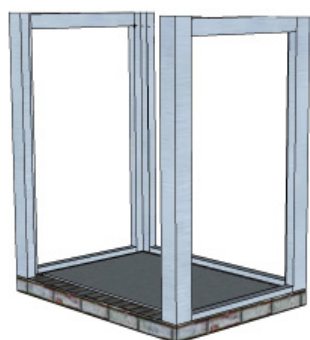

STEP 4: POSITIONING OF THE UNIT & BACK FRAME

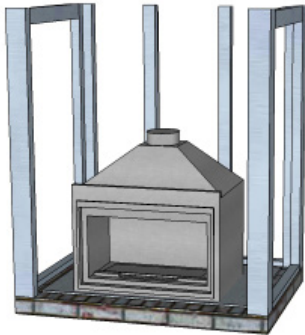

Place the firebox into position onto the sheet metal. For structural support place a steel frame (minimum 51mm thick) on the back wall and connect to the two side steel frames, remembering to leave a 100mm air gap to all sides of the firebox.

****IMPORTANT****

It is strongly recommended that the steel frame allows for a distance of 300mm to the ceiling, this allows the cavity lid to be placed directly above and stop heat from travelling above the lid via the frame.

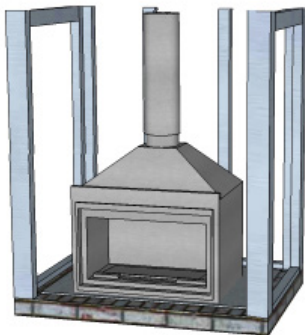

STEP 5: FIRST LENGTH OF FLUE

Place the first single skin length of flue (with no crimp) around the outside of the spigot. You may also use Fire Cement to seal the joins. Before installing the remaining lengths of flue please go to the next step.

STEP 6: SIDE WALLS - SECOND LAYER & VENTILATION

****IMPORTANT****

Ventilation is required on the enclosure to help with air circulation. A minimum of two air intake grills are required at the bottom and a minimum of two air out-take grills are required on top of the masonry enclosure (2X inflow 2X outflow). All vents can be positioned either side OR the front of the masonry enclosure. ALL vents must adhere to the minimum vent size of size 300cm².

***The vent sizes and quantity can be adapted and changed BUT they must meet the minimum ventilation requirements as specified above. For custom made vents please contact your nearest dealer. ALL VENTS MUST BE CONSTRUCTED FROM A HEAT RESISTANT MATERIAL.**

Using a heat resistant sheet on the exterior of the sides and back of the enclosure to the ceiling.

***All air-vents must have a minimum clearance to combustibles of 600mm in front and 300mm above the metal vent itself.**

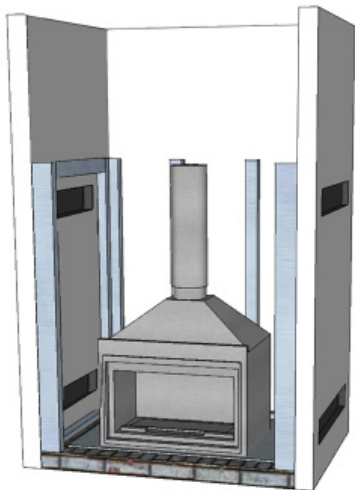

5. INBUILT INTO ISLAND WALL

STEP 7: LIFT UP DOOR ASSEMBLY (IF NOT REQUIRED GO TO STEP 9)

****IMPORTANT****

Refer to images page 38. LIFT UP DOOR ASSEMBLY.

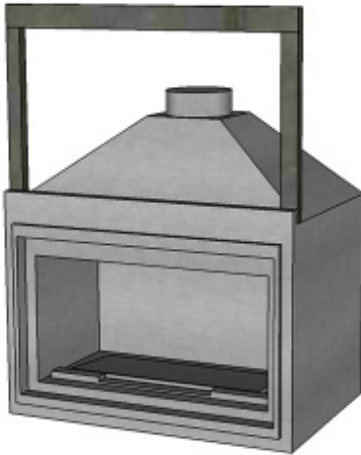

Three bolts mount the lift up door mechanism. It is recommended that you use two solid pieces of timber approximately 450mm long in order to assist in the assembly of the door.

1. Lift the door into position and place door lift mechanism in position above fireplace door.
2. Lift ballast and place timbers in-between guillotine movement of slider to prevent ballast from coming back down.
3. Fix the 3 silver bolts into the heater frame through the ballast frame
4. Release weight from the wood when mechanism is secure in place.
5. Lift ballast and secure chains through sprocket onto the small bolts attached to door (make sure spacers for chain are inserted into link attached to door)
6. Release weight from the wood when chain is secured on both sides of door.

Door should now lift and lower with ease, please test this before continuing.

STEP 8: OUTDOOR AIR KIT (IF NOT REQUIRED GO TO STEP 10)

Any depression or lack of fresh air within the room where the fireplace is located can cause emanation of smoke to flow back into the room and the unit to run inefficiently. It is highly recommended that an Outdoor Air Kit be installed in six or more star rated homes, or any install where a mechanical device (ie. fan), takes air from the fireplace cavity & transfers it.

Place adaptor on the back of the unit and screw into position. Attach the flexi flue to the adaptor which can either run under floor if the home is on stumps and connect to a metal vermin proof cowl or a custom kit can be made with solid flue lengths going from the enclosure of the fireplace and into the roof cavity.

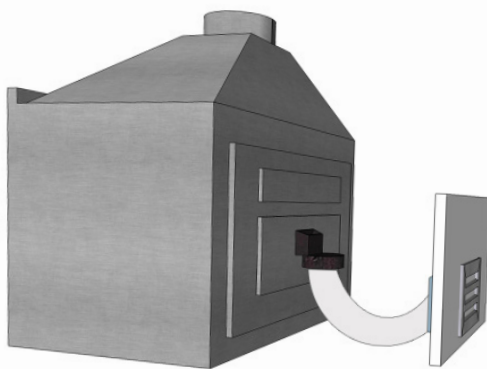

STEP 9: LAYLA 3 TRIM WITH LIFT DOOR (IF NOT REQUIRED GO TO STEP 11)

****IMPORTANT**** Trim must be fitted onto the firebox PRIOR to installing the front of the masonry enclosure.

1. Remove the spacers on the sides of the trim
2. Put the trim on the front of the firebox
3. On the side of the façade of the firebox drill two holes at 4.2mm
4. The holes must match with the slotted holes on the trim
5. Put the trim into place
6. Fix the trim with the screws provided (screws M5 + washers)

LAYLA 3 TRIM WITH NO LIFT DOOR (IF NOT REQUIRED GO TO STEP 11)

If the trim is to be assembled to fit onto a firebox not equipped with a lift up door, you will need to weld the bracket (width 5mm each). The brackets (2 x 5mm) are necessary to compensate the initial width of the trim.

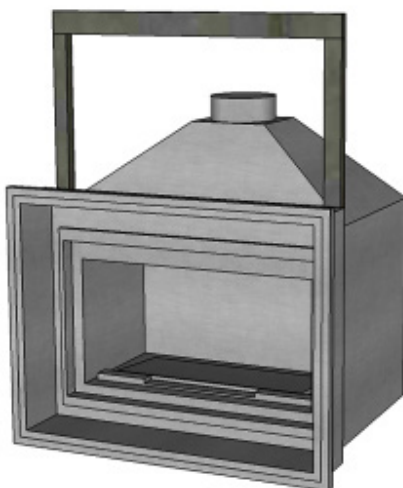

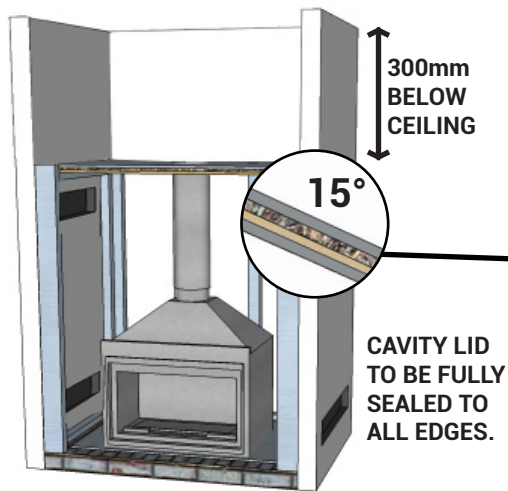

STEP 10: CAVITY LID

****IMPORTANT****

SIDE VENTS

It is highly recommended the cavity lid be installed flat to ensure sufficient air flow around the appliance if 2 vents are used.

FRONT VENTS

It is highly recommended the cavity lid be installed on an angle of 15° facing the front of the fireplace to ensure sufficient air flow around the appliance.

The cavity lid must be installed 300mm below the ceiling and is comprised of the following; minimum 0.5mm thick steel plate for support, followed by a 12mm thick heat resistant sheet, with 1 x 25mm Rockwool sheet. A hole is to be cut in the centre of the lid in order for the single skin flue to penetrate through tightly. You may also use a heat resistance sealant (i.e. Firecork) and heat proof tape to seal any air gaps.

Please ensure the cavity lid is fully sealed to all edges.

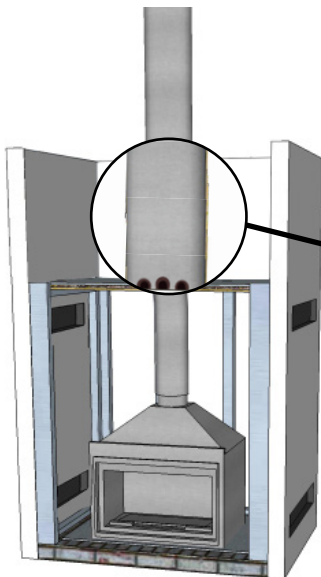

STEP 11: FLUE INSTALLATION

Triple skin flue is to then be continued on top of the cavity lid. The lower end of the triple skin casing shall be close fitting against the lid and the outer casing must be ventilated. Air vents on the first length of triple skin flue must be cut (please use diagram as a guide), or manufactured into the bottom length of the flue.

STEP 12: FLUE INSTALLATION

Where the flue passes through the lid of the enclosure the flue shall be single skin, the triple skin flue must sit on top of lid of the enclosure. The lower end of the triple skin casing shall be close fitting against the lid and must be ventilated.

The triple skin flue will then be continued into the roof cavity and above the roof line, as per Australian & New Zealand Standard AS/NZ 2918:2018. There must be a 25mm clearance around the outer triple skin flue, the flue must extend a minimum 1m above the roof line and have a 3m diameter clearance from the top of the cowl to any objects in a horizontal direction.

****IMPORTANT****

The flue should not include more than two 45° degree bends. The angle of these bends cannot exceed more than 45° and can have no more than one length of 900mm flue between them.



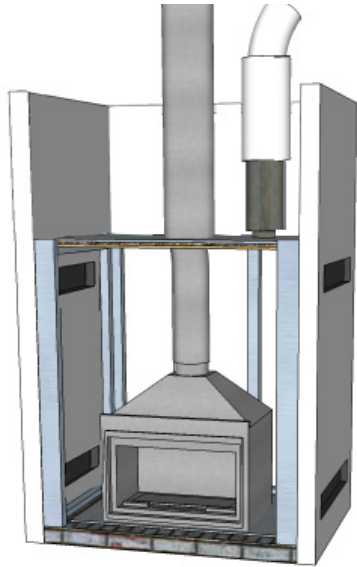

STEP 13: DUCTING

The duct **MUST** be 4 Zero type (aluminium inner core, aluminium outer, poly insulated, minimum RI.0) and tested to AS 4254.1-2012. Outlet **MUST** be metal.

This unit has been supplied with a ducting kit (consisting of one duct and one metal register), while it is highly recommended that it be installed, if not installed it will have no implication on the functioning of the unit.

Cut a hole in the lid of the enclosure nearest to the room where the heat is to be transferred. Run the ducting from this hole into the roof space and locate to the room, cut out the plaster and install a metal register into the ceiling of the next room.

****PLEASE NOTE: A maximum duct run of 6m is recommended, no more than two ducts should run off this cavity.**

If an in-line fan is fitted to the ducting kit, then an Outdoor Air Kit is obligatory and **MUST** be installed to the unit. All ducting must be fireproof.

FAN MUST BE METAL NOT PLASTIC

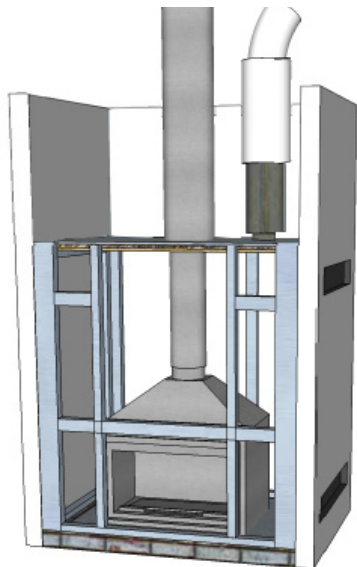

STEP 14: FRONT FRAME

Place a steel frame (minimum 51mm thick) on the front of the enclosure, ensuring a minimum 25mm clearance to the unit itself.

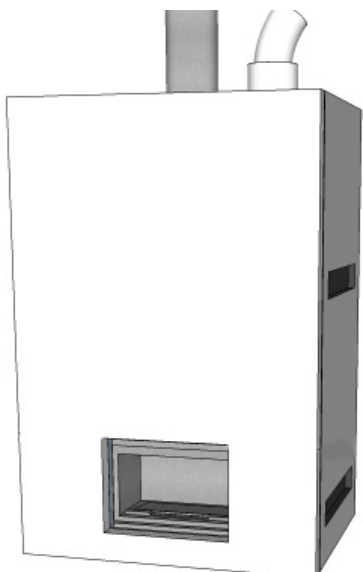

STEP 15: FRONT: FINAL LAYER

Place a layer of 12mm thick heat resistant material on the exterior and finish. Place a sheet of rockwool on the inside face.

****IMPORTANT****

Do not use Gyproc Fyrcek on the fireplace cavity

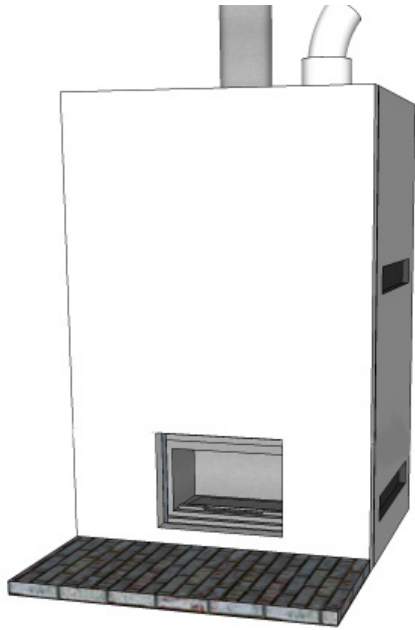

STEP 16: HEARTH (FLOOR PROTECTOR)

The hearth must be constructed from masonry or a non combustible material, and must extend 500mm in front of the appliance, 250mm on either side of the appliance and a thickness of 75mm.



STEP 17: BAFFLE PLATE

Ensuring the wider end of the baffle plate is facing the inside back wall of the firebox, and the flat surfaces are positioned downwards, proceed to gently position the plate on the lugs located on the inside ceiling of the firebox. Once in position ensure the plate sits securely, the baffle plate should not rock or shift when touched if placed correctly.

EXISTING BRICK CHIMNEY INSTALLATION

PLEASE READ ALL INSTRUCTIONS BEFORE COMMENCING INSTALLATION

Install unit into cavity with a sufficient amount of air flow on the back and sides (recommended 25mm air gap) of the appliance.

Single skin flue must run from the spigot of the unit through to the top of the chimney, alternatively a funnel system can be custom made by a qualified trades person to the specifications of the existing brick chimney, the manufacturer and distributor bears no liability to the performance of the appliance once the custom panel has been fitted to the firebox.

DUCTING

The unit has been supplied with a ducting kit (consisting of one duct and one metal register) in order to transfer heat into another room in the home. While it is highly recommended that it be installed, if not installed it will have no implication on the functioning of the unit.

PLEASE NOTE: A maximum duct run of 2 x 6m is recommended. If an in line fan is fitted to the ducting kit, then an Outdoor Air Kit is obligatory and MUST be installed to the unit.

FAN MUST BE METAL NOT PLASTIC

HEARTH

The hearth must be constructed from masonry and must extend 500mm in front of the firebox and 250mm on either side of the firebox with a thickness of 75mm.

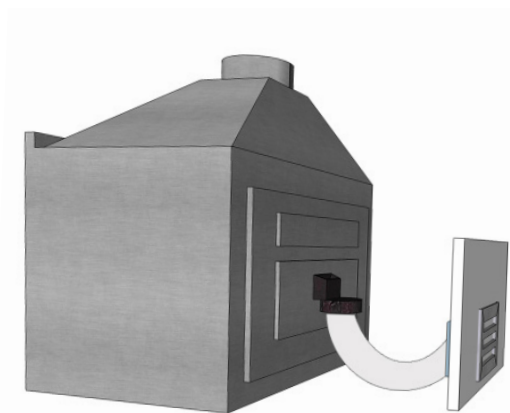

OUTDOOR AIR KIT (OPTIONAL)

Any depression or lack of fresh air within the room where the fireplace is located can cause emanation of smoke to flow back into the room and the unit to run inefficiently. It is highly recommended that an Outdoor Air Kit be installed in six or more star rated homes, or any install where a mechanical device (ie. fan), takes air from the fireplace cavity & transfers it.

Place adaptor on the back of the unit and screw into position. Attach the flexi flue to the adaptor which can either run under floor if the home is on stumps and connect to a metal vermin proof cowl or a custom kit can be made with solid flue lengths going from the enclosure of the fireplace and into the roof cavity.



BAFFLE PLATE

Ensuring the wider end of the baffle plate is facing the inside back wall of the firebox, and the flat surfaces are positioned downwards, proceed to gently position the plate on the lugs located on the inside ceiling of the firebox. Once in position ensure the plate sits securely, the baffle plate should not rock or shift when touched if placed correctly.

VENTILATION OPTIONS

Ventilation is required on the enclosure to help with air circulation.



OPTION 1: INSTALL UNIT FREE STANDING

Recommended 100mm clearance on the sides and back of the firebox

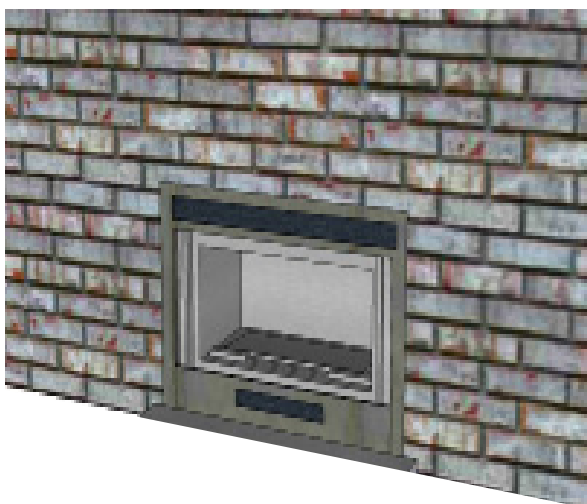

OPTION 2: INBUILT WITH VENTS ON THE BOTTOM AND TOP OF THE FIREBOX

Custom made vent facade can be made with a minimum metal vent size of 100mm x 600mm on the top of the firebox and another 100mm x 600mm metal vent on the bottom of the firebox. Please note that the firebox must be elevated using masonry material so that a sufficient amount of air flows underneath the appliance.

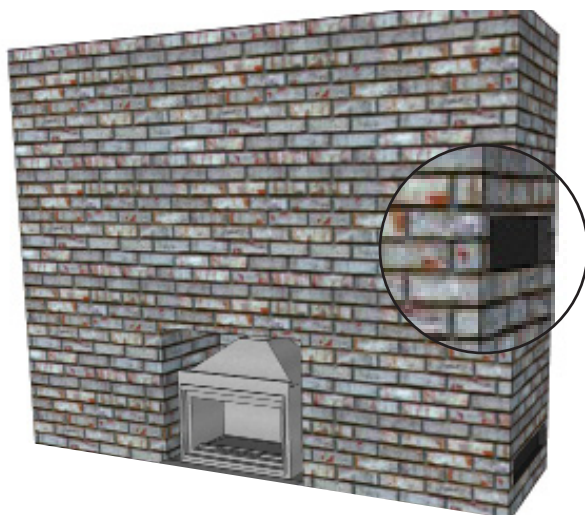

OPTION 3: INBUILT WITH SIDE VENTS*

A minimum of two air intake grills are required at the bottom and a minimum of two air out take grills are required on top of the masonry enclosure. All vents can be positioned either side OR the front of the masonry enclosure.

Minimum vents sizes are 100mm x 300mm with a minimum quantity of four

The vent sizes and quantity can be adapted and changed BUT they must meet the minimum ventilation requirements as specified above. For custom made vents please contact your nearest dealer. **ALL VENTS MUST NOT BE PLASTIC OR COMBUSTIBLE.**

All air vents must have a minimum clearance to combustibles of 600mm in front and 300mm above the metal vent itself.

STEP 1: HEARTH (FLOOR PROTECTOR)

Where combustible flooring is concerned, lay a masonry base. This can be made from tiles, granite, slate, concrete, hebel blocks, etc. The base must be a minimum 75mm thick and must protrude 500mm on all sides of the firebox.



STEP 2: CLEARANCES

****IMPORTANT****

The unit must maintain a 1200mm clearance horizontally in all directions to anything combustible, apart from a ceiling clearance which is not to be less than 1500mm vertically.

Masonry material can be used as a heat shield to reduce clearances to the unit and flue system, please refer to Australian & New Zealand Standards AS/NZS 2918:2018.

STEP 3: LIFT UP DOOR ASSEMBLY (IF NOT REQUIRED GO TO STEP 4)

****IMPORTANT****

Refer to images page 38. LIFT UP DOOR ASSEMBLY.

Three bolts mount the lift up door mechanism. It is recommended that you use two solid pieces of timber approximately 450mm long in order to assist in the assembly of the door.

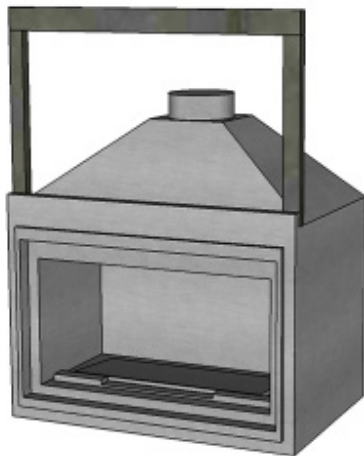

1. Lift the door into position and place door lift mechanism in position above fireplace door.
2. Lift ballast and place timbers in-between guillotine movement of slider to prevent ballast from coming back down.
3. Fix the 3 silver bolts into the heater frame through the ballast frame.
4. Release weight from the wood when mechanism is secure in place.
5. Lift ballast and secure chains through sprocket onto the small bolts attached to door (make sure spacers for chain are inserted into link attached to door).
6. Release weight from the wood when chain is secured on both sides of door.

Door should now lift and lower with ease, please test this before continuing.

STEP 4: OUTDOOR AIR KIT (IF NOT REQUIRED GO TO STEP 5)

Any depression or lack of fresh air within the room where the fireplace is located can cause emanation of smoke to flow back into the room and the unit to run inefficiently. It is highly recommended that an Outdoor Air Kit be installed in six or more star rated homes, or any install where a mechanical device (ie. fan), takes air from the fireplace cavity & transfers it.

Place adaptor on the back of the unit and screw into position. Attach the flexi flue to the adaptor which can either run under floor if the home is on stumps and connect to a metal vermin proof cowl or if on a masonry wall the kit can be placed on the rear of the unit, attach the flexi flue to the adaptor and run to the external brick wall, then proceed to connect the metal vermin proof cowl onto the outside wall.

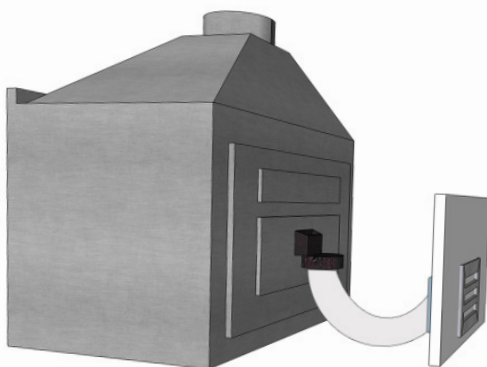

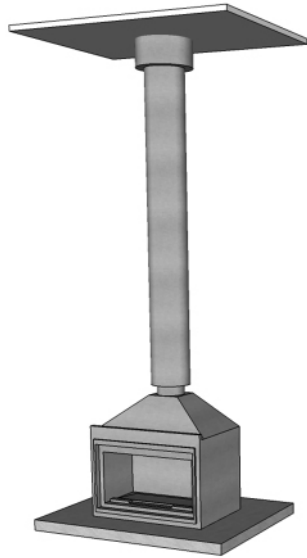

STEP 5: INSTALLING FREE STANDING FLUE SYSTEM

The first length of black double skin flue does not have a crimped end on either side of the flue piece. Place this first length on the outside of the firebox spigot, ensure the inner lugs are facing down closest to the firebox so that the second skin cannot move down and impede on the damper system.

Continue double skin flue to the required ceiling height. The the painted length of triple skin flue (also known as the "Dropper Box") is to extend 150mm below the ceiling. Please refer to Australian & New Zealand Standard AS/NZ 2918:2018.



STEP 6: FLUE INSTALLATION

The triple skin flue will then be continued into the roof cavity and above the roof line, as per Australian & New Zealand Standard AS/NZ 2918:2018. There must be a 25mm clearance around the outer triple skin flue. The flue must extend a minimum 1m above the roof line and have a 3m diameter clearance from the top of the cowl to any objects in a horizontal direction.



STEP 7: BAFFLE PLATE

Ensuring the wider end of the baffle plate is facing the inside back wall of the firebox, and the flat surfaces are positioned downwards, proceed to gently position the plate on the lugs located on the inside ceiling of the firebox. Once in position ensure the plate sits securely, the baffle plate should not rock or shift when touched if placed correctly.

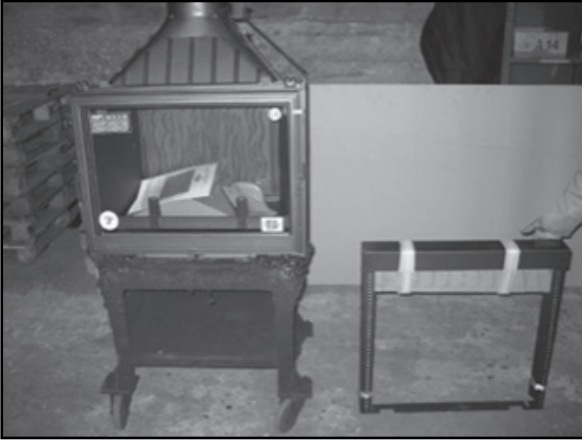

LIFT UP DOOR ASSEMBLY

Three bolts mount the lift up door mechanism. It is recommended that you use two solid pieces of timber approximately 450mm long in order to support the counterweight in the frame, this will assist in the assembly of the door.

*** Ensure to remove the timber pieces once completed ***

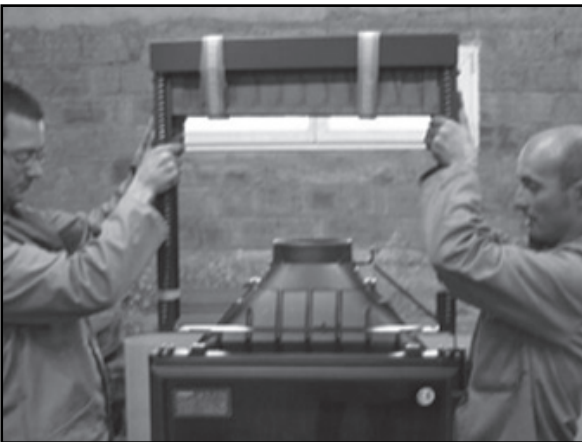

1. Lift the door into position and place door lift mechanism in position above fireplace door.
2. Lift ballast and place timbers in-between guillotine movement of slider to prevent ballast from coming back down.
3. Fix the 3 silver bolts into the heater frame through the ballast frame
4. Release weight from the wood when mechanism is secure in place.
5. Lift ballast and secure chains through sprocket onto the small bolts attached to door (make sure spacers for chain are inserted into link attached to door)
6. Release weight from the wood when chain is secured on both sides of door.

Door should now lift and lower with ease, please test this before continuing.

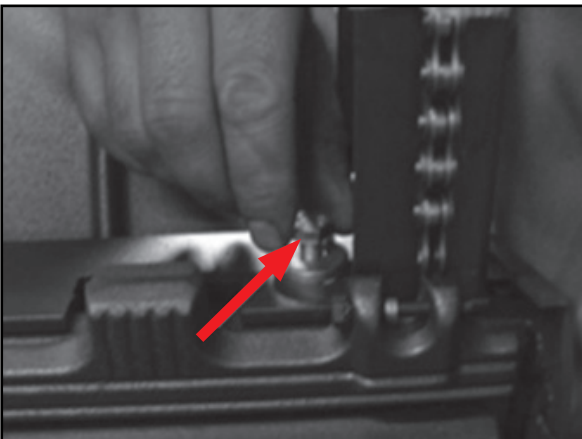
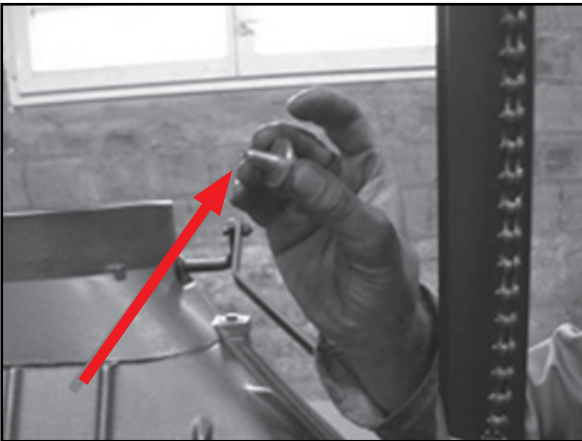

OPERATION & USER GUIDE

OPERATING THE WOOD BURNER WITH THE DOOR OPEN EXPOSES YOU TO MULTIPLE HAZARDS (FALLING EMBERS, SMOKE EMISSIONS IN THE ROOM, ETC.). ALWAYS OPERATE THE APPLIANCE WITH THE DOOR CLOSED.

PRECAUTIONS FOR THE FIRST IGNITION - CURE WITH 10 SMALL FIRES

The first ten fires should be light, moderate and not overly loaded with wood. We recommend a small fire consisting of 3-4 logs weighing around 3kg in total.

PAINT

It is strongly recommended that no person(s) come into contact with the external faces of the appliance without the protective gloves provided, this will avoid any 'marking' on the paint surface prior to it being cured. The paint will polymerise after several fires. Do not scrub or clean the fireplace with any rough surface (such as a sponge). In the case of accidental scratches, make several fires until the paint is cured, at which time you can delicately clean the outside of the appliance with a hot sponge. Do not scratch or rub the fireplace while it is lit. It is recommended contact with the fireplace should be kept to a minimum. Do not paint the fireplace using products NOT recommended by the supplier, please contact your authorised dealer should you require further assistance.

Avoid scratches and markings on your appliance by not placing any objects on your appliance during operation and when not in use.

VENTILATION

A strong burning smoke odour may be smelt during the first several fires, it is therefore recommended to ventilate the premises by opening windows/doors in order for the paint to cure. This phenomenon will disappear after these initial burns cycles.

LIGHTING THE FIRE

The fire is started with the airways open. The fire-lighting starter and the combustion control must allow maximum air intake. In order to limit smoke emission, it is preferable to use the inverted or top-down fire lighting method (see illustration below). An initial load of 3kg of wood provides a good layer of embers.

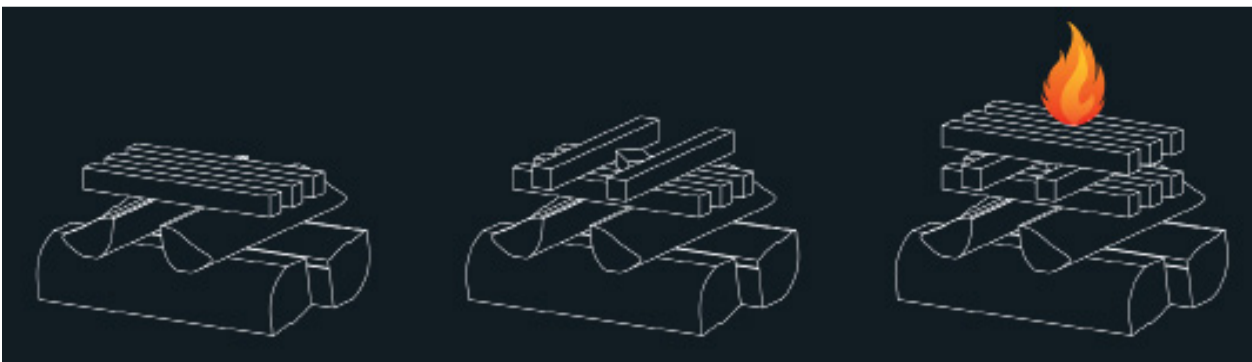

IGNITION INSTRUCTIONS

Before any ignition ensure the damper and primary air is open in order to accelerate combustion and evacuate the fumes. This adjustment should then be reduced as the fire has stabilised in order to maintain a longer fire term and avoid any possible overheating. The door of the fireplace should be closed in order to avoid any risk of back-flow.

Always slowly and gradually light the fire; split wood and fire starters are recommended. It is strictly forbidden to use any volatile substances including; methylated spirits, gasoline, solvents or the likes as these will result in a risk of explosion or thermal shocks by a sudden rise of temperature.

OPERATION & USER GUIDE (CONTINUED)

IGNITION INSTRUCTIONS (continued)

After an extended time of non-use, it is recommended that the firebox be checked and cleaned by a professional to ensure there is no obstruction in the flue and no blocking of the manoeuvring members (damper) before ignition.

DAMPER & AIR SLIDE CONTROLS

The best way to control the fire is to completely close the primary air slide and to adjust the speed with the air flow control. If the air supply seems sufficient you can partially open the primary air slide for a while. The more air you will supply into the stove, the more intense your fire will be, but with a shorter time of combustion. On the contrary, a reduced quantity of air would increase the combustion with less heat output.

DAMPER CONTROLS



Swing Door Damper OPEN

Swing Door Damper CLOSED

Lift & Swing Door Damper OPEN

Lift & Swing Door Damper CLOSED

AIR SLIDE CONTROLS

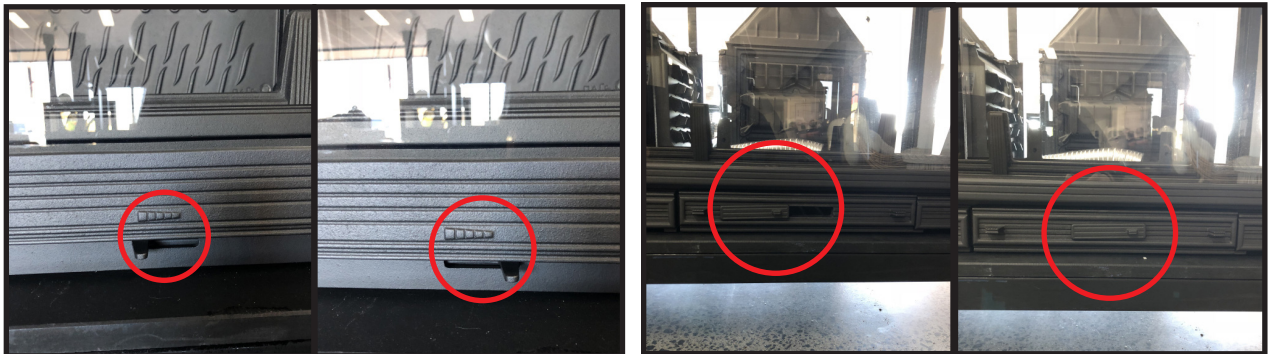

Swing/Swing & Lift Door Air Slide OPEN

Swing/Swing & Lift Door Air Slide CLOSED

Multivision Series Air Slide OPEN

Multivision Series Air Slide CLOSED

ESTABLISHING THE FIRST FIRE

Before establishing the first fire, remove all labels or equipment parts located in the ash box or in the furnace.

While building your first fire, keep the combustion rate at a moderate level to ensure that the sealant binds with the paint. All materials should be seasoned. Flow of air can be regulated by the damper controls at the front of the unit (controls shown above). Except for the short time required to build a fire, the fireplace door should be fully closed. If doors are left partly open, flue gas may be drawn out of the opening creating risks from both fire and smoke.

ESTABLISHING THE FIRST FIRE (CONTINUED)

Please note: Before building a big fire, establish several fires. The curing process is necessary to ensure that the paint is not damaged and that the insert is well seasoned.

Do not overload the furnace. The optimum amount of fuel should not exceed one third of the insert volume. Before reloading, make sure that the fire has subsided. This will keep the fireplace from over-firing.

IMPORTANT

Ventilation devices which operate with the fireplace on the same premises or on the premises which share the same ventilation shaft may not function properly.

Please ensure the grate is never blocked.

During installation please allow for access to have the fireplace and the connecting shaft cleaned.

If required, install cut-off and stifling devices.

RECOMMENDED FUEL

This fireplace is designed for only wood fuel. Any fuel other than wood is strictly forbidden.

As a general rule it is recommended; use dry, well-seasoned **HARD WOOD** with a 15% moisture content or less in order for the unit to burn effectively and avoid any tarring. The heating output of wood depends on the moisture percentage.

AVERAGE WOOD DRYING TIME BASED ON MOISTURE CONTENT

	C	L		C	L
DIRECTLY CUT	75%	78%	1 YEAR	33%	35%
3 MONTHS	48%	62%	1 1/2 YEAR	18%	27%
6 MONTHS	37%	46%	2 YEARS	16%	24%
9 MONTHS	36%	38%	2 1/2 YEARS	15%	24%

C: Chunks L: Logs

If the wood is piled up loosely, it will burn faster because the necessary oxygen for the combustion will easily reach every piece of wood. This piling is recommended if you want to heat over a short period of time. When the wood is piled more compact, it will burn slower as the combustion air cannot reach all the logs at the same time. This piling is recommended if you want to heat over a longer period of time.

IT IS FORBIDDEN TO OPERATE THIS FIREBOX WITH THE DOOR OPEN.

DOOR: Do not open the door too fast as this will create a suction of smoke inside the room.

ATMOSPHERIC CONDITIONS

Misty or foggy weather may possibly favour back-flow of the smoke, which may be a health hazard. In this case only use the fireplace as is necessary.

For safety reasons, assemblies of appliances and accessories not provided or recommended by Seguin or Sculpt Fireplaces are NOT PERMITTED. Unsuitable equipment may cause dysfunctions and disorder upon use.

EXTINGUISHING THE FIRE

Stop fuelling the fire and let it burn out. The fire should burn out without any constraints. Do not close the air slides before the fire is completely extinguished, otherwise it may release noxious gases.

CAUTION: Do not hang or install objects within 2m of the appliance. This includes paintings, photos, televisions, and any other combustible material.

OPERATION & USER GUIDE (CONTINUED)

IMPORTANT WARNING

Storing any flammable materials (paper, linen, furniture, solvents, flammable liquids, spray containers, gas bottle, etc.) close to the fireplace is strictly forbidden.

All these products should never be stored even for a short while in wood storages or recesses laid out under or near the appliance.

CAUTION: The window, the front panel of the appliance, as well as all external faces including the facade, will attain high temperatures (above 100°C). Uninitiated persons, young children and infants should be monitored at all times while in the vicinity of the appliance.

SLOW BURNING

Please be aware that this method may cause unburnt matter to accumulate in the flue system. This may in the long term cause a chimney fire. Our recommendation is to therefore avoid closing the air controls for an extended length of time. Use only dry hard wood with a maximum moisture content of 15% to assist in reducing creosote build up, and regularly light a high intensity fire to burn off the build up.

A draught is created from the difference in temperature between the interior and the exterior flue. The higher the temperature inside the flue, the more intense the draught is. Before closing the air inlets and reducing the combustion level in the stove for a slow burn, the temperature inside the flue must be high enough to adequately draw all the flue gas.

CAUTION: Continuous and intensive slow burn operation may cause early deterioration of the appliance and its components, as well as a chimney fire if the flue has not been regularly cleaned.

TRANSITION PERIOD, INSUFFICIENT CHIMNEY DRAUGHT AND POOR WEATHER CONDITIONS

Pay attention to the operations of the insert during transition periods and/or when chimney draught is insufficient or when weather conditions are unfavourable, especially during severe cold weather. Such conditions may cause flue gas to flow into the room. To prevent such a situation, you should reduce the intensity of fire by curbing the influx of air into the combustion chamber until smoke disappears. Afterwards you may increase air flow monitoring for any appearance of smoke in the room.

MAINTENANCE

The vitro-ceramic glass can withstand temperatures of up to 750°C. If the glass breaks following a handling error, it is not recommended to replace it using a material other than that supplied by the manufacturer. The original glass quality must be used to maintain any warranty of the wood stove.

Before the first fires in autumn we strongly recommend cleaning the top of the appliance to prevent carbonising the dust that could then be deposited on the convection grate. It is important to regularly check that the convection grates are clean.

CLEANING THE GLASS

The window of the fireplace requires regular cleaning with specific products intended for this use. The use of moist hard wood with a moisture content above 15% causes excessive creosote build up on the glass. Once again we recommend only burning very dry hard wood.

We recommend waiting for the glass to cool before cleaning it. The use of products that are too aggressive (eg. abrasive cleaners) may lead to the deterioration of some of the wood heater parts. An effective and ecological method of cleaning the glass is to use a piece of damp newspaper dipped in ash and then rinsing with clean water. You can also use a commercially available glass cleaning product.

MAINTENANCE (CONTINUED)

FLUE & FIREBOX

Flues should be professionally cleaned and checked twice a year, including at least once during the peak period of use and more if required. A professional should also check seals, door ropes, baffle plates and all consumable parts of the firebox and flue to ensure the unit is in safe working order.

OVERFIRING

Incorrect or excessive loading of fuel can overfire firebox and cause irreparable damages. Ensure a maximum fuel load not exceeding 1/3 of firebox volume. Overfiring will void all warranties.

CORRECT LOADING

To ensure unit is not overfired, please use the following lighting guide for reference.



INCORRECT LOADING

The following image is an example of incorrect unit operation, overfiring. Unit use such as below will void all warranties.



MAINTENANCE (CONTINUED)

DO NOT REMOVE THE BAFFLE EXCEPT WHEN PERFORMING A CHIMNEY SWEEP

CAUTION: Cracked and/or broken components (eg. glass panels or baffles) may render the installation/operation unsafe. Do not use the appliance if this is the case and contact your dealer.

ASH PAN

The ash pan should be emptied regularly in order to avoid any overflow and clogging of the fire grate. Use the cold handle supplied and pull the ash pan from the appliance. You will find some ashes catching in the cavities between the ribs of the fireplate. This bed of ashes caught between the fireplate is essential as it will create a more effective start up operation of the fire.

FORBIDDEN FUELS

This appliance is not designed for burning the following fuels:

- Solid mineral fuels (all coals or similar)
- Liquid mineral fuels (Gasoline, fuel oil, solvents, drainage oils or similar)
- Methylated spirit
- Creosote-treated woods and too moist or green woods
- Paper or cardboard
- Wood workshop residues (Shavings, saw dusts or similar)
- Other forbidden fuels that may harm the appliance or the environment

CHIMNEY SWEEPING

Prior to using and installing into an existing chimney, it's necessary to perform a chimney sweep and ensure it's clear of any build up (creosote, bird's nest, etc). Chimney sweeps should be performed twice a year, including at least once during the period of use.

CHIMNEY FIRES

Chimney fires can be caused due to incorrect use of the appliance and lack of periodic cleaning.

Visible signs of a chimney fire include:

- Abundant fumes
- Strong smell of soot
- Roaring in the flue
- Significant increase in the temperature of the flue
- Cinders flying out of the top of the flue

MAINTENANCE (CONTINUED)

CHIMNEY FIRES (CONTINUED)

Suggested course of action in case of chimney fires:

1. Put out the fire by carefully removing the glowing logs and fully close the fireplace door.
2. Use a chimney sieve screen (metal mesh 2 x 10mm, preferably brass, on a 60x60cm frame). Place the screen on the chimney top and inspect the lower parts for cracks through which fire flames may escape. A hot screen reduces the draught in the chimney and, consequently, slows down the soot burning process.
3. When required, call the Fire Department.

In the event of any emergency, put out the fire immediately by cutting off airflow into the insert and, where necessary, cover glowing wood with sand. Try to remove fuel from the hearth.

Do NOT use water to put out the fire as it may cause permanent damage.

TROUBLESHOOTING AND COURSE OF ACTION TO PUT OUT THE FIREPLACE IN THE EVENT OF AN EMERGENCY.

NOTE: These course of actions are only recommendations. For more detailed information contact your dealer or licensed technician

Symptoms	Possible cause	Proposed course of action
1. Smoke comes from the fireplace	<ol style="list-style-type: none"> 1. Air supply ventilation is choked 2. Size of chimney shaft or its length is not sufficient 3. Fault location of chimney relevant to roof ridge 4. No chimney cap installed 5. Improper connection of insert with smoke shaft 6. Chimney not clear 	<ol style="list-style-type: none"> 1. Provide a clear ventilation shaft 2. Extend chimney 3. Extend chimney 4. Mount chimney cap 5. Apply reducer between fireplace insert and smoke shaft 6. Call authorised specialist
2. Ash comes from the fireplace	Too much ash in ash box	Remove ash from ash box, clear grate
3. Glass becomes dirty	Most likely improper firewood used (too much resin, too wet or wood from coniferous trees) or inadequate draught in chimney	Use special cleaning agent or clean ash from fireplace. If inadequate draught, see other troubleshooting suggestions.
4. Starting a fire is a problem or fire is weak	<ol style="list-style-type: none"> 1. Logs too thick 2. Wood too wet 3. Ash box full 4. Chimney cold 5. Air supply installation malfunctions 6. Chimney not clear 	<ol style="list-style-type: none"> 1. Use recommended fuel 2. Use seasoned firewood 3. Remove ash from ash box, clear grate 4. Heat up chimney by burning more paper 5. Provide or clear ventilation shaft 6. Call authorised specialist
5. Fire is too strong	<ol style="list-style-type: none"> 1. Fireplace door open 2. Too strong draught in chimney 	<ol style="list-style-type: none"> 1. Close door 2. Install draught regulator
6. Movable part is damaged in use (grate, baffle board, rear panel, side panels, glass plate, seals)	Parts subjected to normal wear and tear need to be replaced (not covered by warranty - see warranty terms and conditions)	Buy new spares from the dealer (dealers information can be found on the website: https://sculptfireplaces.com.au/stockists/)

EUROPA 7 PARTICULATE EMISSIONS, POWER OUTPUT AND EFFICIENCY TEST

TESTING LABORATORY	HRL Technology
MANUFACTURER	Seguin Duteriez
MODEL	Europa 7 Evolution
ISSUE DATE	14.12.2015
INVESTIGATING OFFICER	Steve Marland
TEST REPORT	HCMG/15/098
RESULTS	The appliance particulate emissions factor was 1.2/kg of hard wood that complies to AS/NZS 4014.1 and the average efficiency of the appliance for all burn rates was 60%.
CONCLUSION	The Europa 7 Evolution plus solid fuel appliance complies with the requirements of AS/NZS 4014/4013 (2014).

MULTIVISION 8000 APPLIANCE POWER OUTPUT TEST

TESTING LABORATORY	HRL Technology
MANUFACTURER	Seguin Duteriez
MODEL	Multivision 8000
ISSUE DATE	02.11.2015
INVESTIGATING OFFICE	Steve Marland
RESULTS	Testing of the maximum power(kW) output of the Visio 8 insert solid fuel appliance was performed at the high burn rate prescribed in AS/NZS4013 (2014) on the 24th of November 2015. The appliance produced a maximum Heat output of 25.9kW
CONCLUSION	Exemption from testing the Visio 8 insert solid fuel appliance should be claimed under section 1.2.3 (b) of AS/NZS4013 (2014) as the maximum heat output from combustion is greater than 25kW when fired at the prescribed high burn rate and that the appliance is intended for space heating by means of transferring heat to the living area by ducted hot air.

TEST REPORTS

VISIO 8 APPLIANCE POWER OUTPUT TEST

TESTING LABORATORY	HRL Technology
MANUFACTURER	Seguin Duteriez
MODEL	Visio 8 Plus
ISSUE DATE	09.12.2015
INVESTIGATING OFFICER	Steve Marland
RESULTS	Testing of the maximum power(kW) output of the Visio 8 insert solid fuel appliance was performed at the high burn rate prescribed in AS/NZS4013 (2014) on the 24th of November 2015. The appliance produced a maximum Heat output of 27.8kW
CONCLUSION	Exemption from testing the Visio 8 insert solid fuel appliance should be claimed under section 1.2.3 (b) of AS/NZS4013 (2014) as the maximum heat output from combustion is greater than 25kW when fired at the prescribed high burn rate and that the appliance is intended for space heating by means of transferring heat to the living area by ducted hot air.

SUPER 9 APPLIANCE POWER OUTPUT TEST

TESTING LABORATORY	HRL Technology
MANUFACTURER	Seguin Duteriez
MODEL	Super 9
ISSUE DATE	09.12.2015
INVESTIGATING OFFICE	Steve Marland
RESULTS	Testing of the maximum power(kW) output of the Visio 8 insert solid fuel appliance was performed at the high burn rate prescribed in AS/NZS4013 (2014) on the 24th of November 2015. The appliance produced a maximum Heat output of 26kW
CONCLUSION	Exemption from testing the Visio 8 insert solid fuel appliance should be claimed under section 1.2.3 (b) of AS/NZS4013 (2014) as the maximum heat output from combustion is greater than 25kW when fired at the prescribed high burn rate and that the appliance is intended for space heating by means of transferring heat to the living area by ducted hot air.

WARRANTY

Seguin fireboxes are guaranteed for 10 years. This excludes the ash pan, bricks and fire grate retainers which are guaranteed for 1 year.

The warranty becomes effective at the date of purchase.

WARRANTY DOES NOT COVER

1. Door seals, ropes, gaskets and glass.
2. Any form of rust and/or corrosion to the painted finish of the heater.
3. Salted air of a coastal region or a highly humid environment may contribute to some oxidation of the cast iron, in this case the warranty is therefore not valid for damages originating from these causes.
4. All defects or faults resulting from poor maintenance, inappropriate use or a non-compliant installation which does not abide by Australian & New Zealand Standards AS/NZS 2918:2018 or instructions are listed in this manual are not warranted.
5. Any device or accessory not provided by Seguin Duteriez or Sculpt Fireplace Collection are strictly forbidden and will result in a void of all warranties by the manufacturer and distributor.
6. No modifications can be made to the firebox or to original components supplied with the appliance.
7. The manufacturer and distributor are by no means responsible for any indirect damage originating from a handling accident.
8. Cost of removal of a defective heater or re-installation of a replacement heater is not covered.
9. All warranties are void if the unit is outside and exposed to the elements
10. Overfiring of fireboxes will void all warranties

PERFORMANCE

The performance of our fireplaces are given as an indication and comparison after testing under optimum conditions. These values reported under standard conditions may be subject to variations if the installation and conditions of use are not equivalent to our testing conditions. In any case, the closed fireplace remains an supplementary form of heat and should not replace a main heating system.

WARRANTY CLAIMS

In the case of a faulty part, the user should immediately inform the retailer and the retailer the distributor, Sculpt Fireplace Collection.

For all warranty claims, we will require photos, proof of purchase and the date of installation along with the compliance certificate from your licensed installer.

The guarantee is strictly limited to the exchange or repair by ourselves of parts agreed to be defective, without exception. Costs of dismantling, installation, assembly and transport will under no circumstance be covered by this warranty by the manufacturer or distributor and should be handled

WARRANTY CARD

DATE OF PURCHASE
PLACE OF PURCHASE
DATE OF INSTALLATION
COMPLIANCE CERTIFICATE NO.
MODEL NO.
NAME AND ADDRESS OF PURCHASER
PHONE NO.
EMAIL ADDRESS
Please include a copy of your receipt and compliance certificate

EMAIL OR POST WARRANTY INFORMATION TO
 info@sculptfireplaces.com.au
 PO Box, 1232 Mornington, VIC 3931
 1300 851 304

SEGUIN 
 DUTERIEZ

Whilst every effort is taken to avoid errors, SCULPT FIREPLACE COLLECTION cannot accept responsibility for the accuracy of any statement, extract or information contained within this manual nor can any of its contributors who have submitted material for inclusion. SCULPT FIREPLACE COLLECTION may change or update this manual and anything described in it without notice. We will endeavour to ensure that information, materials and data on this site are complete, accurate and up-to-date. Information on this manual is for guidance only and cannot cover all circumstances. E&OE

Sculpt Fireplace Collection is an Australian owned company who exclusively supply some of world's most sought after **high-end luxury fireplaces.**

Intent on providing Australians with a dynamic collection of designer fires, Sculpt fireplace collection has strategically gathered not only award winning fireplace designs, but also fireplaces that have been manufactured with high quality materials and the best raw steel that is built to last.

Our wood fire manufacturers integrate innovation, technology, environmental impact, operational expertise and quality, whilst holding design at the forefront. We aim to fill homes with the maximum of comfort while capturing the true art and meaning of a sculptural fireplace in any living space.



JC BORDELET
créateur d'harmonie

SEGUIN
DUTÉRIEZ

Sculpt is proud to be the sole importer of Seguin, Axis and Bordelet fireplaces, with exclusive distribution rights throughout Australia and New Zealand.



SCULPTTM

FIREPLACE
COLLECTION

1300 851 304
info@sculptfireplaces.com.au
www.sculptfireplaces.com.au

Edition 12/03/2021