

# SCULPT™

FIREPLACE  
COLLECTION

## JC BORDELET

Eva 992 | Zelia 908 | Lea 998 | Tatiana 997 |  
Linea 914

---

### 1. SPECIFICATIONS & COMPONENTS LIST

- 1.1 BORDELET TATIANA 997
- 1.2 BORDELET LEA 998
- 1.3 BORDELET ZELIA 908
- 1.4 BORDELET EVA 992
- 1.5 BORDELET LINEA 914

### 2. PRELIMINARY INSTALL GUIDE

### 3. INSTALLATION GUIDE

### 4. OPERATION & MAINTENANCE

### 5. WARRANTY

### 6. TEST RESULTS

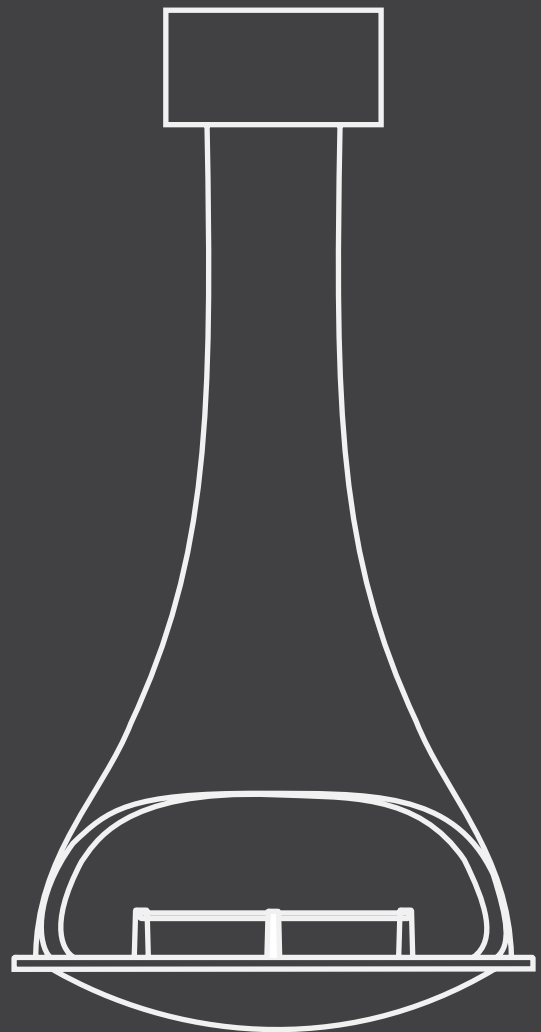

#### NOTICE TO INSTALLER:

These instructions must be left with the owner, who should keep them for future use.

## COMPLIANCE PLATE AND SERIAL NUMBER.

**THE BORDELET UNITS IN THIS MANUAL CONFORM TO AUSTRALIAN AND NEW ZEALAND STANDARDS AS/NZS 2918:2001 DOMESTIC SOLID FUEL BURNING APPLIANCES & AS/NZS 4012/4013(2014).**

### **IMPORTANT**

Heating capacity of the following appliances are a guide only and refers to areas with 2.4m ceilings and 6 or more star rated buildings. Heating output may vary depending on factors such as building characteristics, quality of insulation and type of firewood used and climate zone.

All dimensions shown are approximate. Check all dimensions accurately prior to installation. In line with our policy of continuous improvement, we reserve the right to alter specifications without notice.

All units comply and MUST be installed to Australian & New Zealand Standard AS/NZS 2918:2001. When in use some parts may become hot, a suitable fire guard is recommended where very young, elderly or infirm are concerned.

The instructions in this manual are recommendations only, the distributor and manufacturer bears no liability to the interpretation of these instructions.

© Copyright 2019 Sculpt Fireplaces Collection

## CONGRATULATIONS!

Thank you for choosing Sculpt Fireplaces as your heater of choice.

Your fireplace is the result of careful design, artisan engineering and safety tests. If it is properly installed, used and maintained, you may be sure that you will have an outstanding heating feature in your home for years to come.

We advise you to read through this guide in order to become acquainted with the installation methods specific to your fireplace.

It is recommended that this fireplace be installed by a qualified and licensed trades professional. You will find in this guide the answers to most of your questions, should you require further assistance we recommend you contact your retailer.

Before igniting your fireplace for the first time, please carefully read this manual.

Follow [@sculptfireplacecollection](#) on Instagram, [SculptFireplaceCollection](#) on Facebook and be sure to post your latest masterpiece installed with the hashtag [#sculptfires](#).

We hope we've helped make you the envy of your friends this winter and for years to come.

**From all of us,  
Sculpt Fireplace Collection**

# Tatiana 997

|   |                                      |
|---|--------------------------------------|
| <b>MATERIAL</b>                               | 4mm thick spun steel                 |
| <b>HEARTH DIMENSIONS</b>                      | Minimum 1770mm diameter X 40mm thick |
| <b>CLEARANCES TO COMBUSTIBLES</b>             | Minimum 750mm                        |
| <b>INCLUDES</b>                               | Fire grate                           |
| <b>FIREPLACE WEIGHT</b>                       | 120kg                                |
| <b>TRIPLE SKIN FLUE SIZES</b>                 | 240mm, 290mm, 340mm                  |
| <b>MINIMUM FLUE HEIGHT</b>                    | 4.5m                                 |
| <b>BEARING FLAME &amp; DROPPER BOX WEIGHT</b> | 50kg                                 |

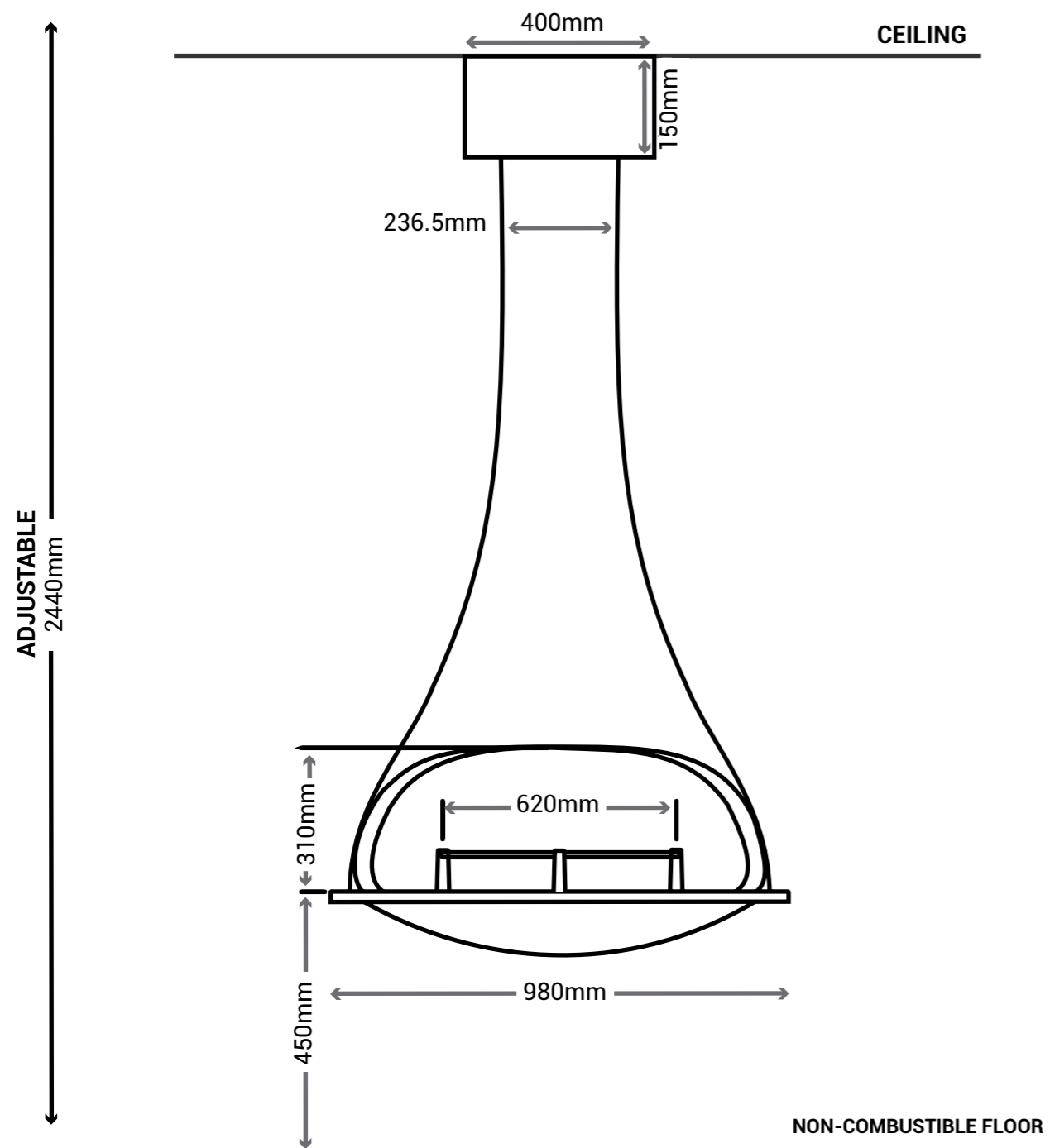

# Tatiana 997

1. BEARING PLATE & DROPPER BOX
2. CEILING COVER PLATE
3. ADDITIONAL PIPE (OPTIONAL LENGTHS)
4. THE FIREPLACE
5. ASH GRATE

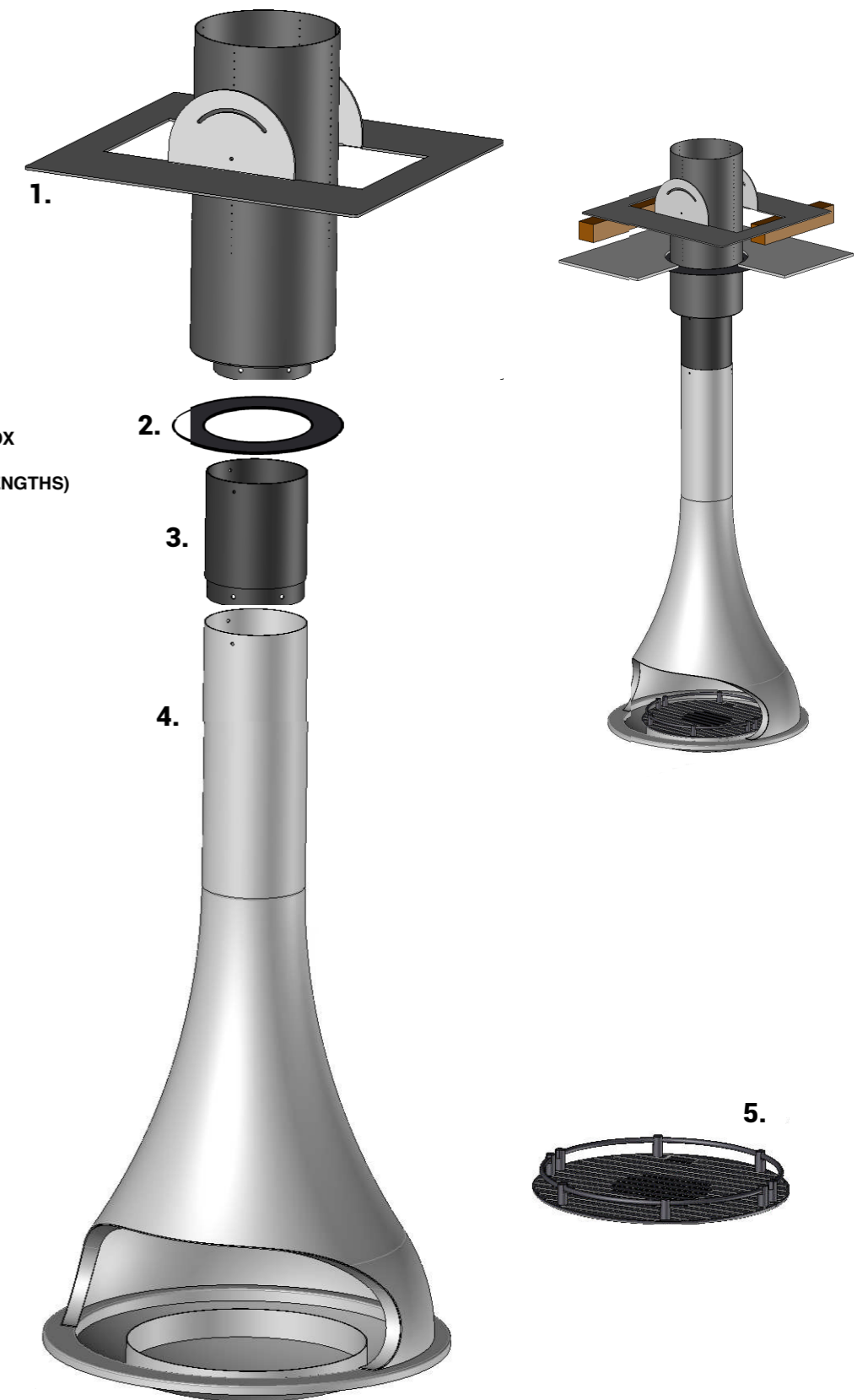

# Lea 998

|   |  |
|---|--|
| <b>MATERIAL</b>                               | 4mm thick spun steel with safety glass |
| <b>HEARTH DIMENSIONS</b>                      | Minimum 1300mm diameter X 40mm thick   |
| <b>CLEARANCES TO COMBUSTIBLES</b>             | Minimum 500mm                          |
| <b>INCLUDES</b>                               | Fire grate and ash pan                 |
| <b>FIREPLACE WEIGHT</b>                       | 130kg                                  |
| <b>TRIPLE SKIN FLUE SIZES</b>                 | 215mm, 265mm, 315mm                    |
| <b>MINIMUM FLUE HEIGHT</b>                    | 4.5m                                   |
| <b>BEARING FLAME &amp; DROPPER BOX WEIGHT</b> | 50kg                                   |

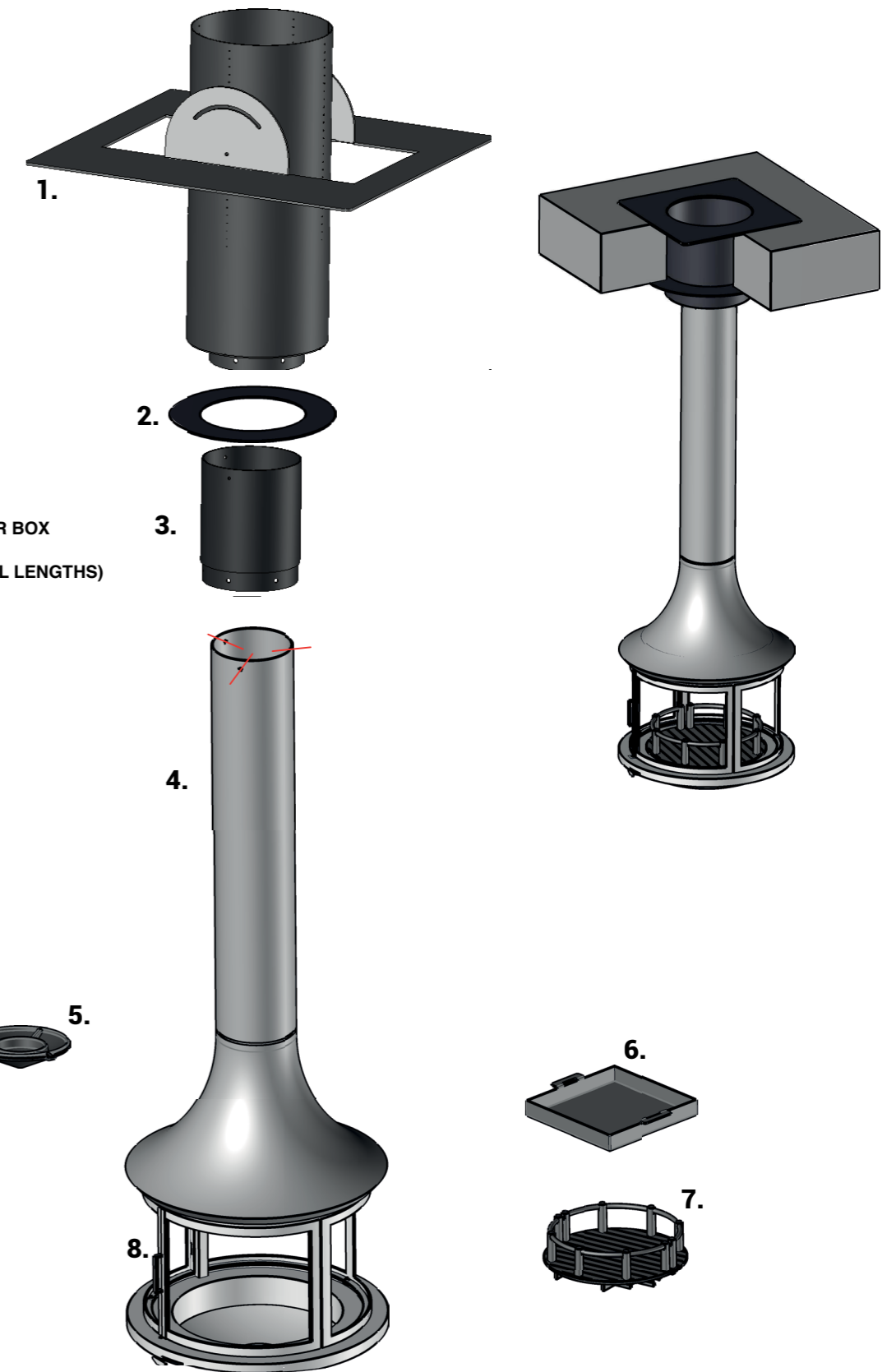
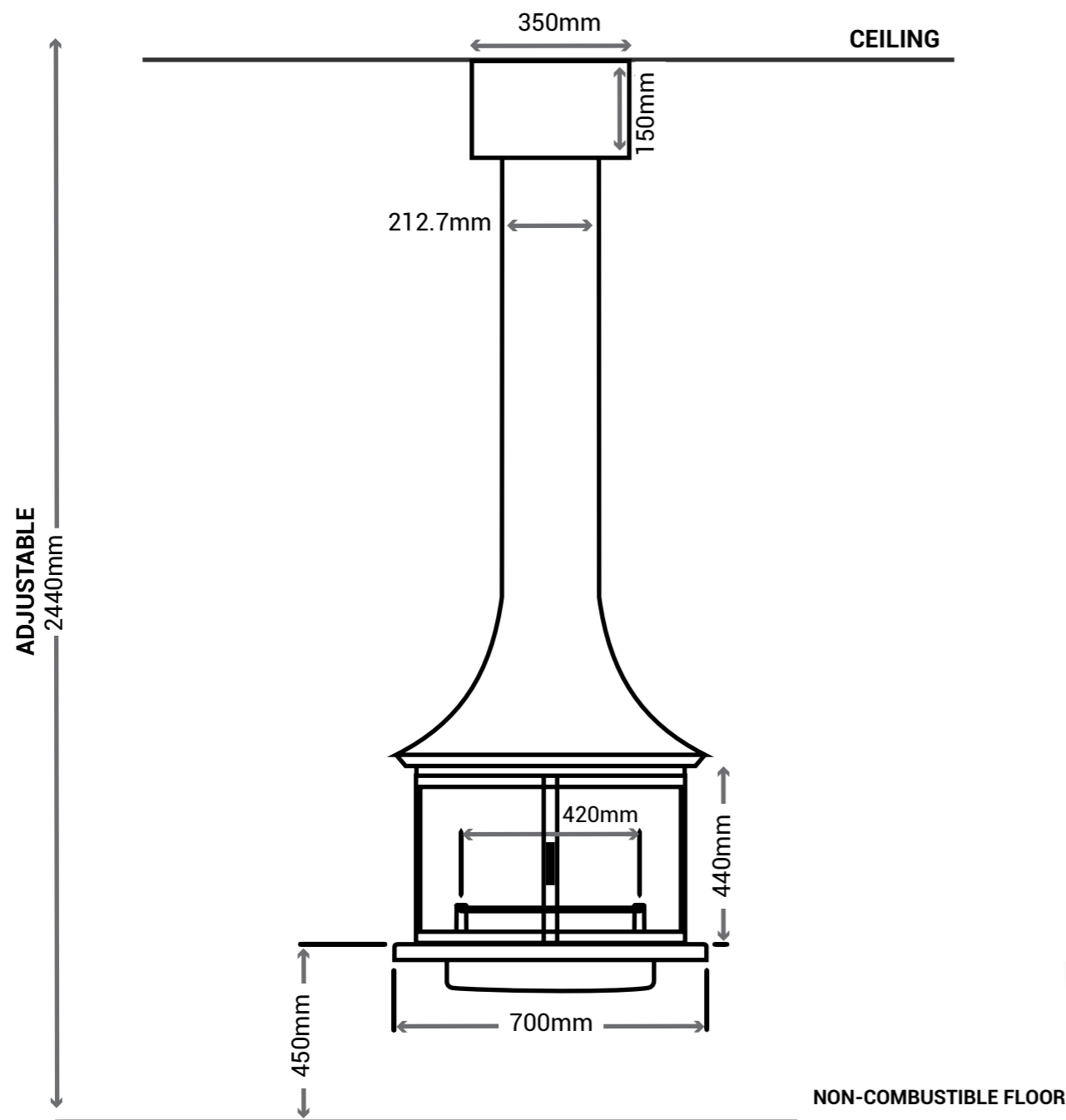

## Lea 998

1. BEARING PLATE & DROPPER BOX
2. CEILING COVER PLATE
3. ADDITIONAL PIPE (OPTIONAL LENGTHS)
4. THE FIREPLACE
5. THE BAFFLE
6. ASH PAN
7. ASH GRATE
8. GLASS PANELS

# Zelia 908

|   |  |
|---|--|
| <b>MATERIAL</b>                               | 4mm thick spun steel with safety glass |
| <b>HEARTH DIMENSIONS</b>                      | Minimum 1770mm diameter X 40mm thick   |
| <b>CLEARANCES TO COMBUSTIBLES</b>             | Minimum 750mm                          |
| <b>INCLUDES</b>                               | Fire grate and ash pan                 |
| <b>FIREPLACE WEIGHT</b>                       | 150kg                                  |
| <b>TRIPLE SKIN FLUE SIZES</b>                 | 240mm, 290mm, 340mm                    |
| <b>MINIMUM FLUE HEIGHT</b>                    | 4.5m                                   |
| <b>BEARING FLAME &amp; DROPPER BOX WEIGHT</b> | 50kg                                   |

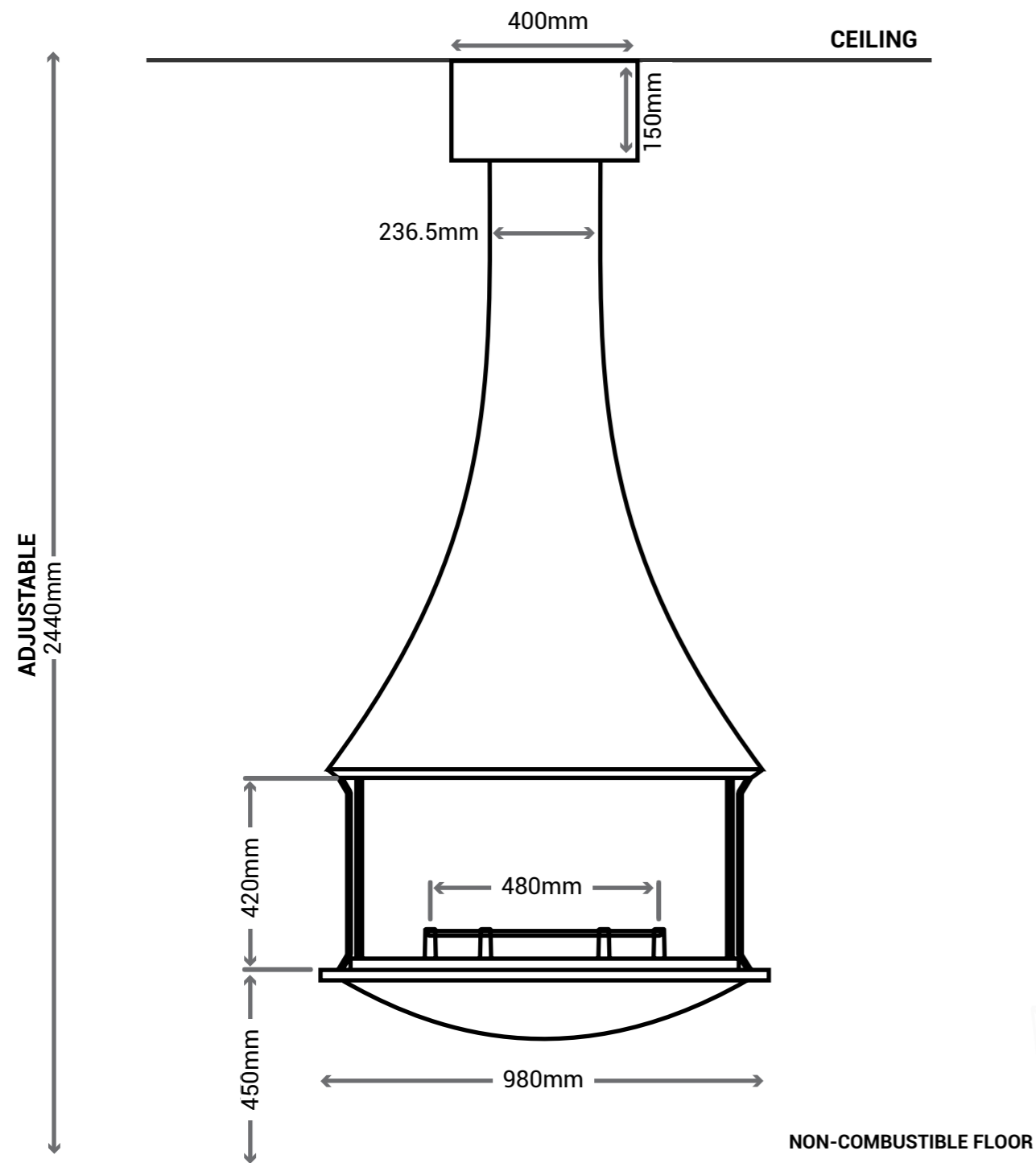

## Zelia 908

1. BEARING PLATE & DROPPER BOX
2. CEILING COVER PLATE
3. ADDITIONAL PIPE (OPTIONAL LENGTHS)
4. THE FIREPLACE
5. THE BAFFLE
6. SLIDING GLASS & FIXED GLASS (X2)
7. ASH PAN
8. ASH GRATE

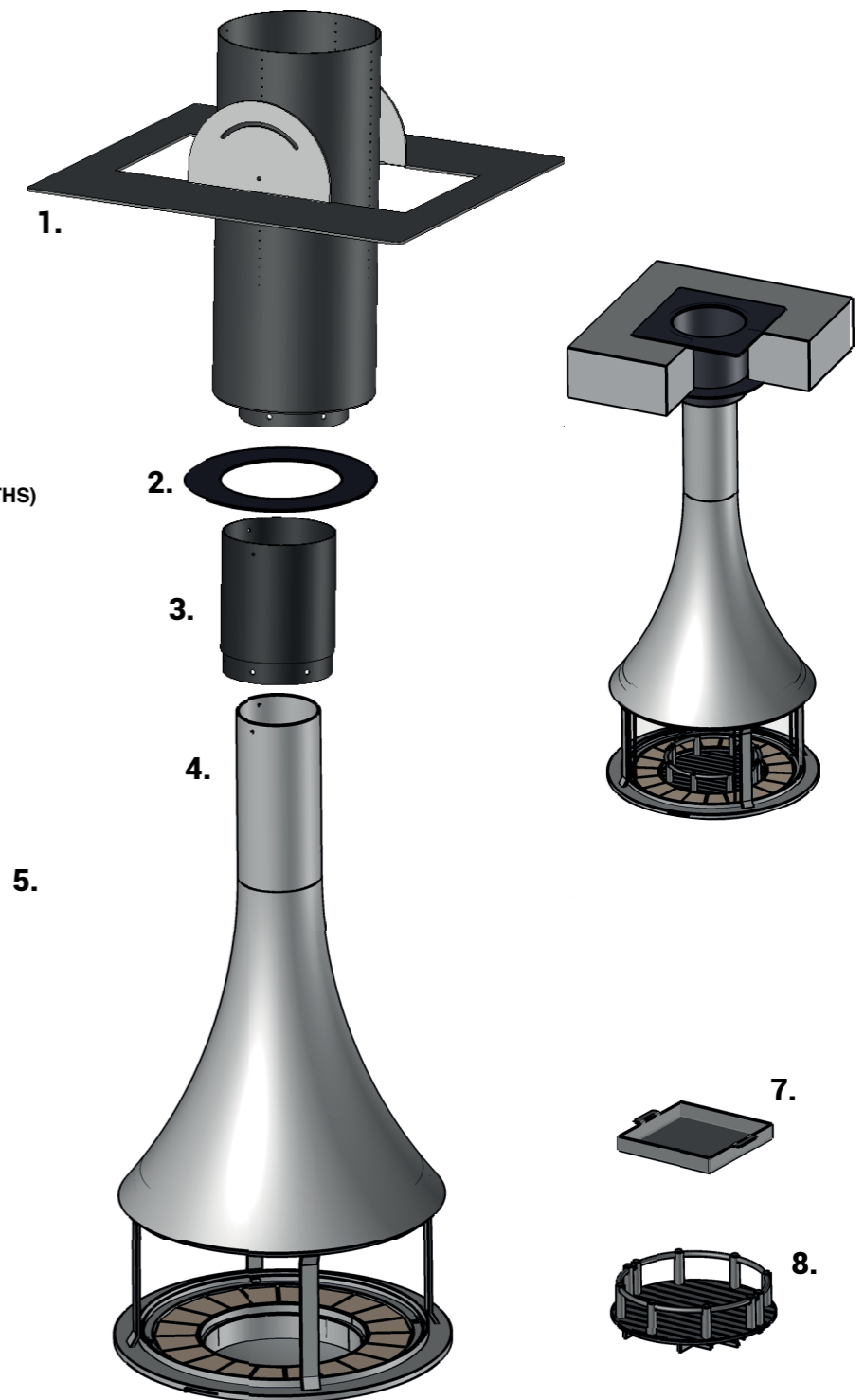

# Eva 992

|   |  |
|---|--|
| <b>MATERIAL</b>                               | 4mm thick spun steel with safety glass |
| <b>HEARTH DIMENSIONS</b>                      | Minimum 1770mm diameter X 40mm thick   |
| <b>CLEARANCES TO COMBUSTIBLES</b>             | Minimum 750mm                          |
| <b>INCLUDES</b>                               | Fire grate and ash pan                 |
| <b>FIREPLACE WEIGHT</b>                       | 200kg                                  |
| <b>TRIPLE SKIN FLUE SIZES</b>                 | 265mm, 315mm, 365mm                    |
| <b>MINIMUM FLUE HEIGHT</b>                    | 4.5m                                   |
| <b>BEARING FLAME &amp; DROPPER BOX WEIGHT</b> | 50kg                                   |

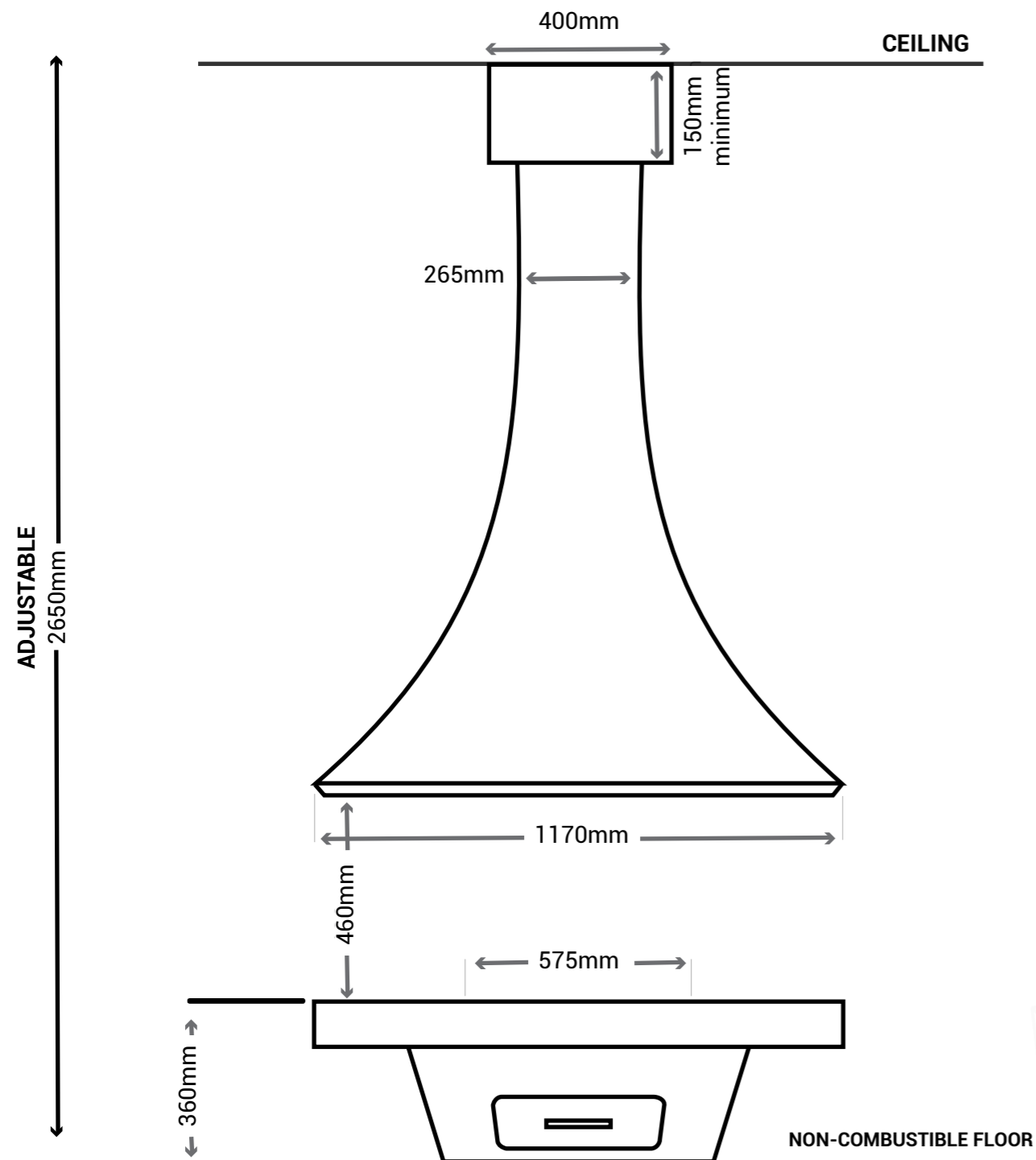

# Eva 992

1. BEARING PLATE & DROPPER BOX
2. CEILING COVER PLATE
3. ADDITIONAL PIPE (OPTIONAL LENGTHS)
4. THE FIREPLACE
5. THE BAFFLE
6. SLIDING GLASS & FIXED GLASS (X2)  
PLACE THE TWO CAPS ON EITHER SIDE OF THE BASE, IF AN OUTSIDE AIR KIT IS INSTALLED UNDER THE FLOOR.
7. METALLIC RING  
PUT IN PLACE THE METALLIC RING TO HIDE SCREWS.
8. THE BASE
9. SHUTTER (X2)
10. ASH PAN
11. ASH GRATE



# Linea 914

|   |  |
|---|--|
| <b>MATERIAL</b>                               | 4mm thick spun steel with safety glass |
| <b>HEARTH DIMENSIONS</b>                      | Minimum 1300mm diameter X 40mm thick   |
| <b>CLEARANCES TO COMBUSTIBLES</b>             | 850mm                                  |
| <b>INCLUDES</b>                               | Fire grate and ash pan                 |
| <b>FIREPLACE WEIGHT</b>                       | 130kg                                  |
| <b>TRIPLE SKIN FLUE SIZES</b>                 | 240mm, 290mm, 340mm                    |
| <b>MINIMUM FLUE HEIGHT</b>                    | 4.5m                                   |
| <b>BEARING FLAME &amp; DROPPER BOX WEIGHT</b> | 50kg                                   |

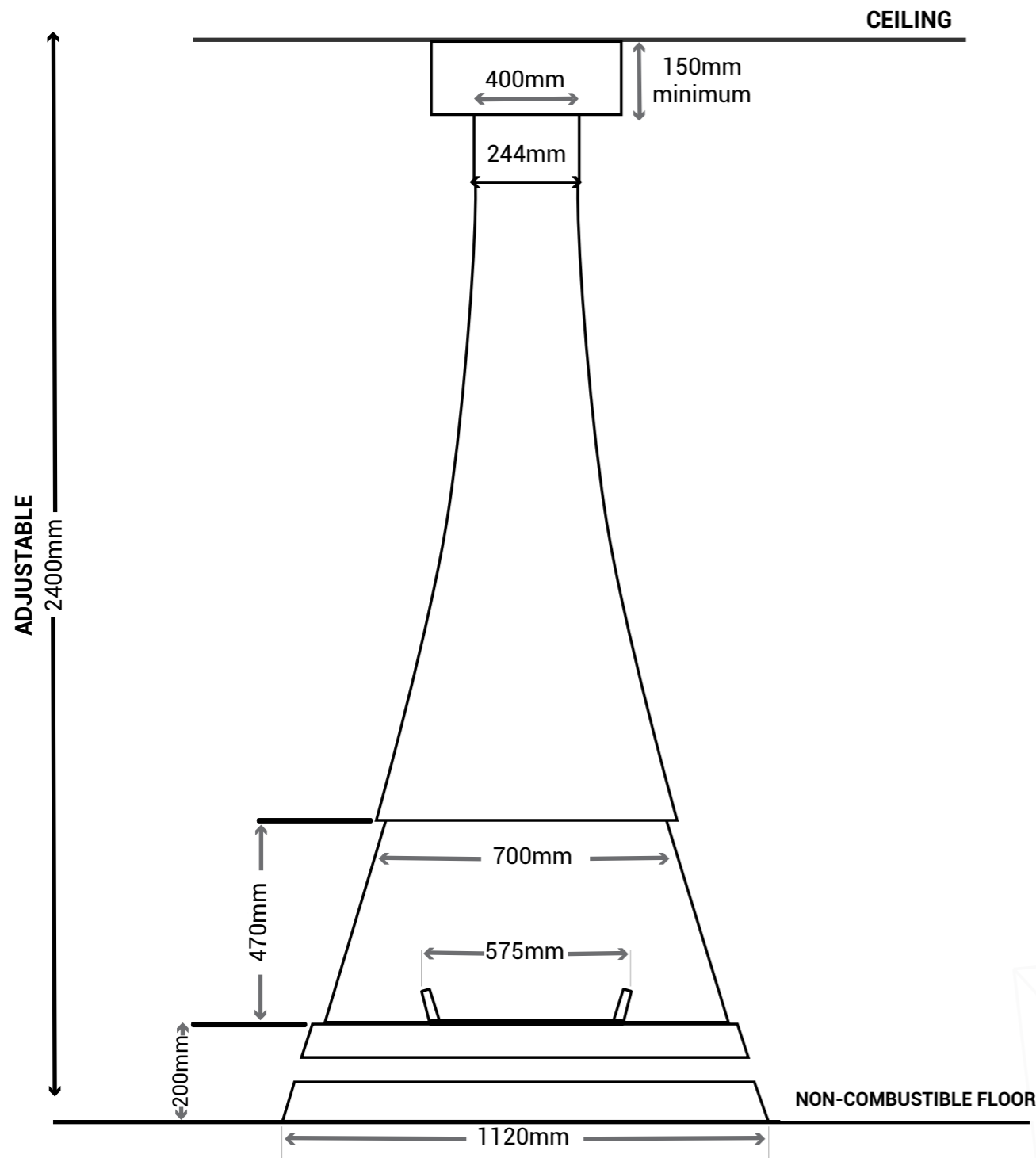

# Linea 914

1. BEARING
2. CEILING
3. ADDITIONAL
4. THE FIREPLACE
5. THE BEARING
6. SLIDING PLATE TO PLACE THE FIREPLACE ON THE CEILING
7. METAL RING TO PUT IN PLACE
8. THE BEARING
9. ASH PAN
10. ASH GRATE

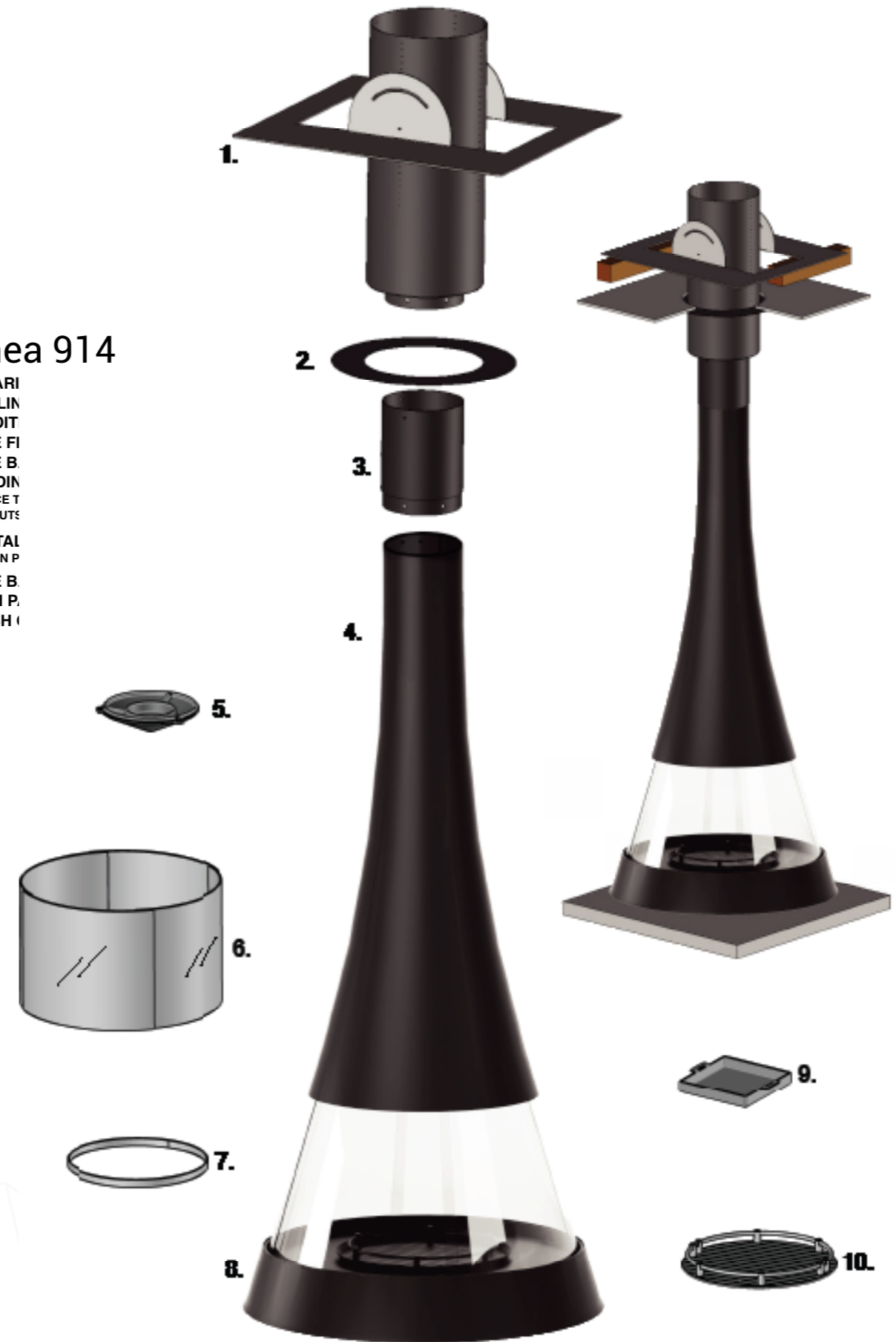



It is the users duty to make themselves aware of and apply all national or more restrictive local standards and instructions (AS/NZS 2918:2018).

### **IMPORTANT**

**Prior to unpacking and installation ensure the appliance has not been damaged during transit. Please ensure you check the glass/door, the air flow damper controls and the door locking mechanism where applicable.**

**Before any work is carried out, as per local and national regulations and laws, this appliance MUST be installed by a licensed professional as per and AS/NZS 2918:2018.**

### **IMPORTANT WARNING**

**It is strictly forbidden to use any combustible materials (ie; wooden framing, plaster, etc) near or around this appliance. Any exception from this rule is a health and safety hazard which will result in a non-compliant installation and a void of warranties.**

**Electrical cables and components must not be placed in the vicinity of the appliance as it is a fire hazard.**

### **PRELIMINARY INSTALL INFORMATION**

For the installation and use of this appliance, the fitter and the user should strictly adhere to local and national regulations in addition to AS/NZS 2918:2018. The installer should comply with the instructions and recommendations detailed in this manual. The safety and operation of the fireplace is directly dependent thereon. The liability of the manufacturer or distributor can neither be retained nor assured following failure of installation or incorrect use which does not comply with AS/NZS 2918:2018.

As each installation is unique, a qualified and licensed trades professional should take all required preliminary precautions depending on the technical elements inherent to each job.

In-observance of the assembly instructions in conjunction with AS/NZS 2918:2018 entails the liability of the person who carries it out.

**As a result of faulty assembly, irrational use of parts or additional components that were not supplied by the manufacturer, and/or modifying of the appliance or components will result in inferior or unsafe operation. Should this occur the manufacturer bears no liability, and will result in a null and void product warranty.**

### **PLEASE READ PRIOR TO INSTALL**

All images and diagrams in this manual are for installation reference purposes only and are not to scale, the distributor and manufacturer bears no accuracy of these images and accepts no liability. The purpose of these images and diagrams is to act as a guide in conjunction with the written components, and are NOT to be used to instruct independently. The order of steps listed in this manual are recommendation only.

It is strongly recommended that the licensed trade professional who is performing the installation of this appliance, completely read and comprehend all instructions in this manual prior to proceeding.

**Sculpt Fireplaces & Bordelet reserves the right to change these specifications without prior notice.**

#### **ACCEPTABLE VARIANCE ALLOWANCE**

Due to the production of these hand crafted and manufactured fireplaces, there is an acceptable allowance of 3-5mm variance of the unit, including the door frame (if applicable). This variance in production is non-claimable under any warranties.

#### **HEAT RESISTANT MATERIALS**

Heat resistant materials must meet AS/NZS 2918:2018 clause 1:4.27 a material with an allowable service temperature of 600° Celsius or greater.



### ASSEMBLING THE FIREPLACE

For reasons of shipping and handling, all our fireplaces are delivered in separate components and require assembly.

Assembly should be carried out according to this manual which should be read in its entirety prior to commencing installation. Any in-observance of the assembly instructions entails the liability of the licensed trade professional who carries it out.

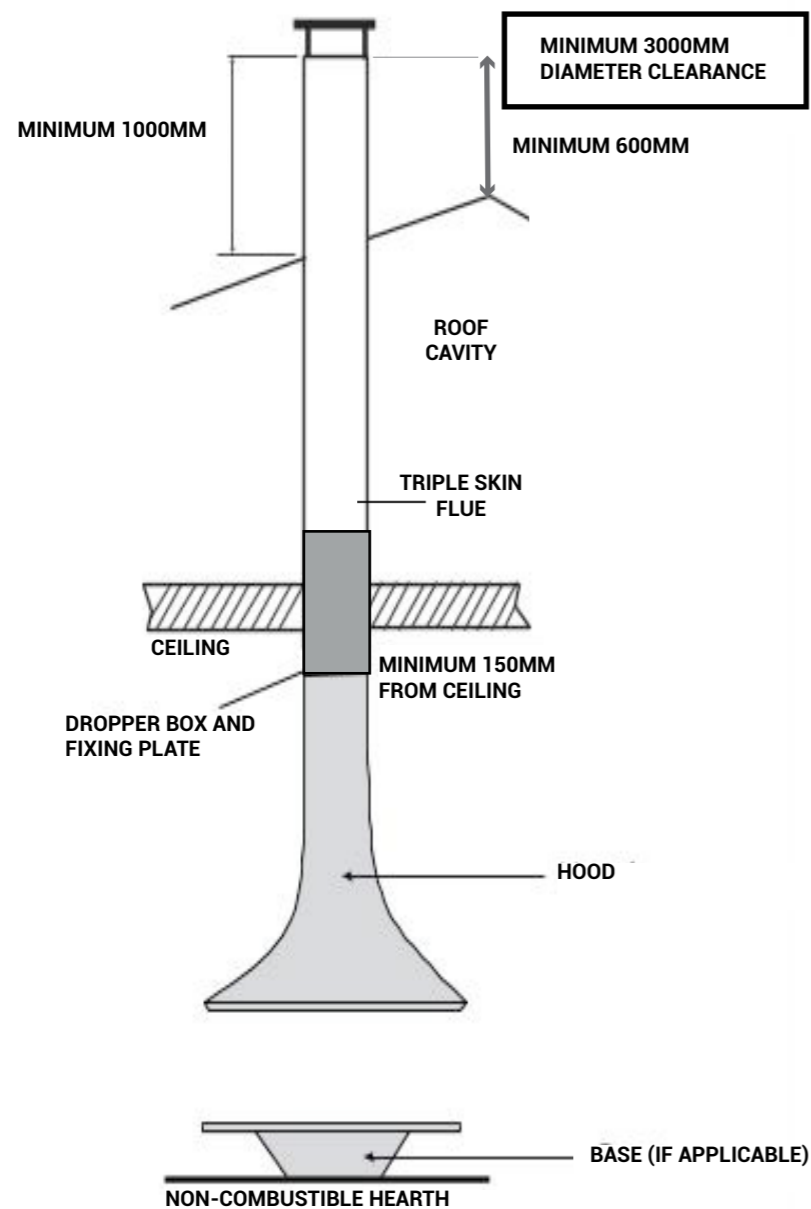

BORDELET EVA 992 DIAGRAM USED

### 1. INSTALLING THE BEARING FRAME AND THE DROPPER BOX

Determine the exact location of the bearing frame and the dropper box above the ceiling in accordance with the proposed location of the; **LEA 998, TATIANA 997** and **ZELIA 908** will be centred in the room and hang a minimum of 450mm above the hearth (non-combustible floor). The **EVA 992** and **LINEA 914** will be centred in the room below and the lowest edge of the fireplace hood will be 820mm above the hearth. Beams in the roof may need to be altered to suit the **Bordelet** bearing frame and dropper box.

**IMPORTANT:** When connected to the bearing frame, the dropper box must sit a minimum 150mm below the ceiling.

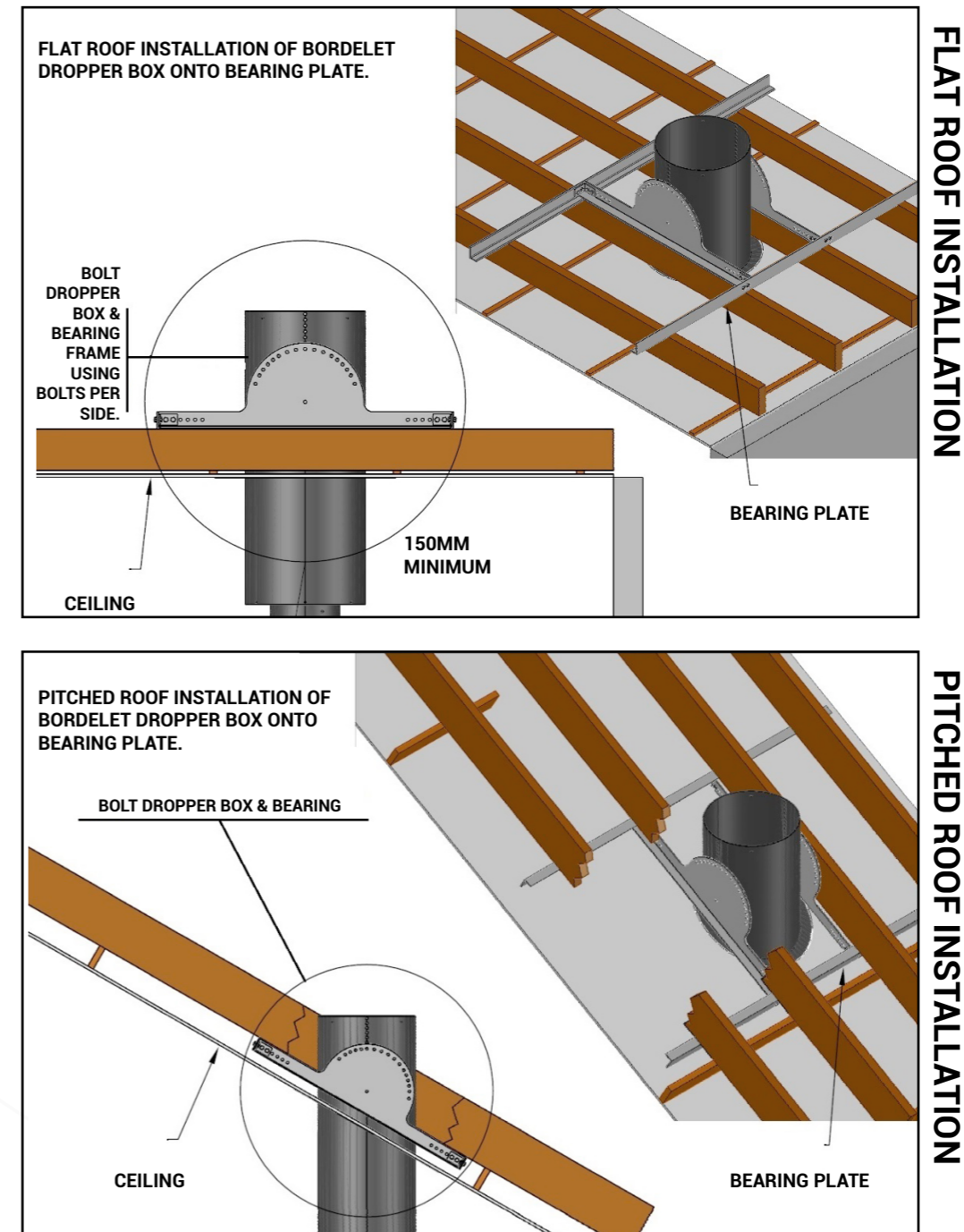

FLAT ROOF INSTALLATION

PITCHED ROOF INSTALLATION

## 2. INSTALLING THE ADDITIONAL PIPES

For added height (floor to ceiling), install the additional pipes (if required), onto the dropper box (using the 3 screws TF M8x16).

## INSTALLING THE FIREPLACE

### LEA 998, ZELIA 908 AND TATIANA 997

Install the LEA 998, TATIANA 997 and ZELIA 908 onto the dropper box (or the additional pipe if requested) with the lower shelf of the fireplace 450 mm above the finished hearth.

### EVA 992 AND LINEA 914

Install the EVA 992 and LINEA 914 canopy onto the dropper box (or the additional pipe if required) with the lower edge of the fireplace hood 820mm above the finished hearth. Make sure that all the fasteners are tight. Centre the base of the EVA 992 and LINEA 914 on the non-combustible hearth in perfect vertical alignment with the hood and bolt it down making sure that the exact 460mm clearance between the canopy and the base is maintained.

## 3. 45° OFFSETS OF CONNECTING FLUES

The connecting flue should not include more than two 45° offsets (i.e. more than one non-vertical portion), the angle of these offsets should not exceed 45° with the vertical.

**IMPORTANT:** When a controlled mechanical ventilation includes an electric extractor, it is absolutely necessary to stop operation of the fireplace. The electric extractors of the kitchen, the bathroom, or the toilets, should also be switched off when operating the fireplace.

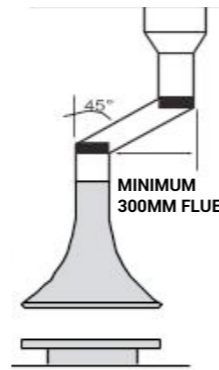

## 4. INSTALLING THE HEARTH NON-COMBUSTIBLE

Centred on the planned location of the fireplace, install a hearth made of approved non-combustible material such as ceramic tiles, stone, masonry or concrete etc.

## 5. INSTALLING THE INTERNAL COMPONENTS

### TATIANA 997, LEA 998 and ZELIA 908

Install the baffle plate ensuring the flat surface is positioned upwards, proceed to gently position the plate on the lugs located on the inside of the fireplace. Once in position ensure the plate sits securely, the baffle plate should not rock or shift when touched if placed correctly. Install the ash pan and the ash grate on the base of the fireplace, it should be noted an ash pan and baffle plate is **NOT** supplied with the TATIANA 997.

### EVA 992 AND LINEA 914

Install the baffle plate ensuring the flat surface is positioned upwards, proceed to gently position the plate on the lugs located on the inside of the fireplace. Once in position ensure the plate sits securely, the baffle plate should not rock or shift when touched if placed correctly. Install the ash pan and the ash grate on the base of the fireplace. Install the ring screw caps at the bottom of the base if necessary. Install the 2 shutters at the bottom of the base, in case the fireplace is not connected to an air intake from the floor.

## 6. AIR INTAKE

Air intake is essential for the proper operation of the appliance, if installed in a well insulated/ 6 or more star rated home. The air intake should be located in an area vented to the outdoors or in an area exposed to non de-pressurised prevailing winds.

The air intake outlet should be located either directly in the chimney, or as close as possible to the appliance. The air intake should be vermin proof.

## MINIMUM FRESH AIR INTAKE

### EVA 992, LINEA 914 AND TATIANA 997

- 300cm<sup>2</sup>

### LEA 998 AND ZELIA 908

- 200m<sup>2</sup>

## 7. INSTALLING ANTI-SWAY BRACKET

If the TATIANA 997, ZELIA 908 and LEA 998, reach a height of more than 4 meters from floor to ceiling then an Anti-Sway bracket must be installed to stabilize the installation and prevent oscillations which might, in the long run, loosen fasteners.

If the EVA 992 and LINEA 914 reaches a height of more than 5 meters from floor to ceiling then an Anti-Sway bracket is highly recommended.

## TYPES OF ANTI SWAY BRACKETS

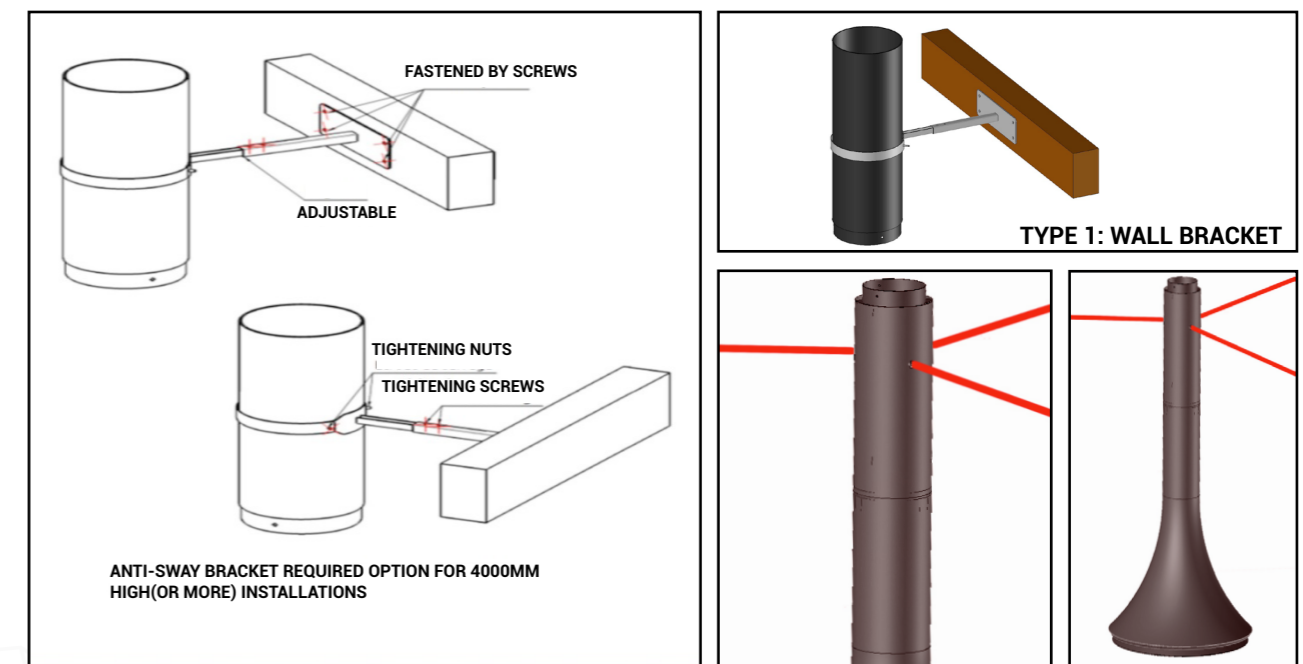

TYPE 2: CENTRAL BELT BRACKET WITH CABLE TIES

## INSTALLING ZELIA 908, EVA 992, AND LINEA 914 SAFETY GLASS PANELS

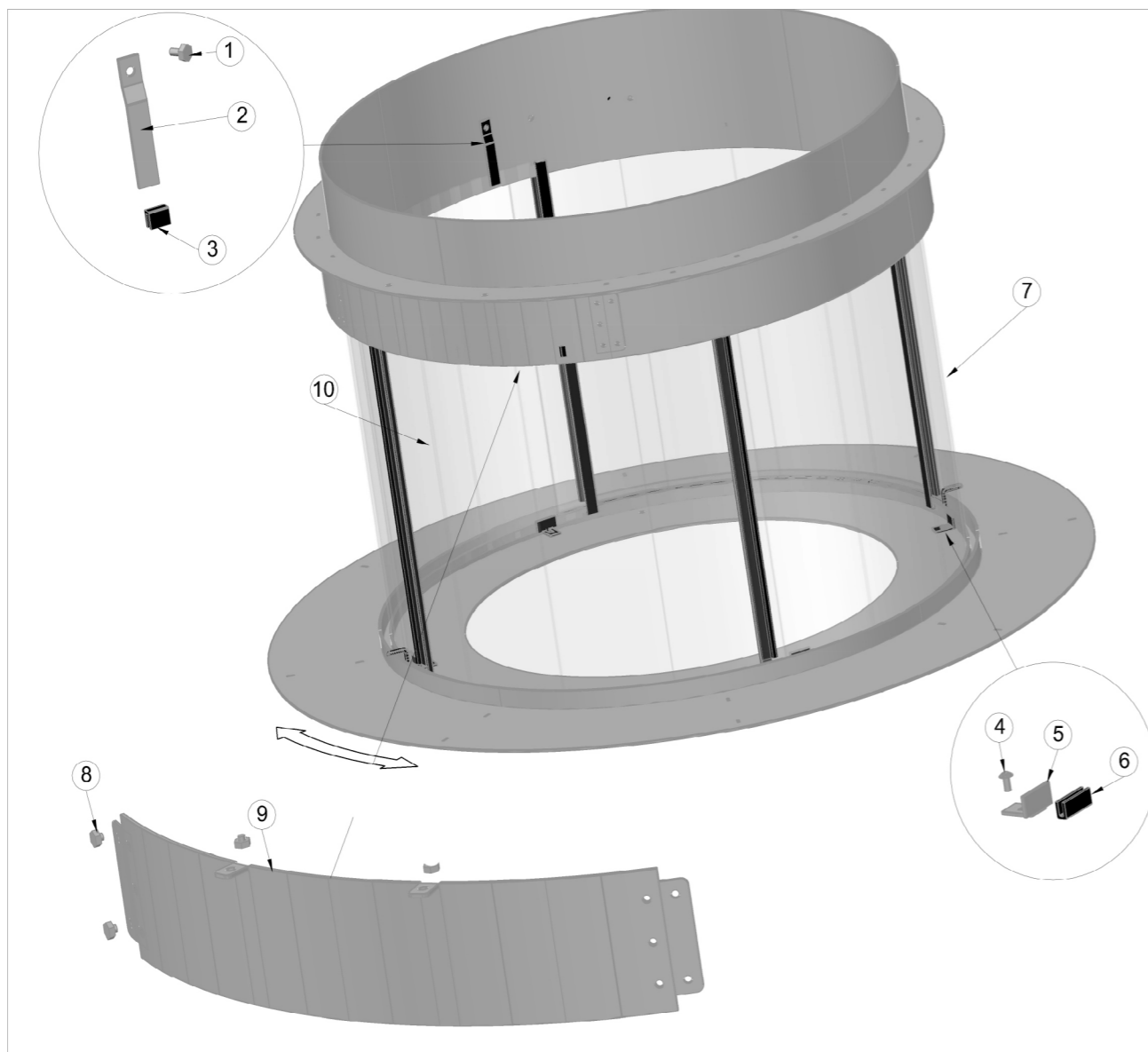

### MOUNTING OF THE FIXED GLASS

1. Insert the glass (7) by the central part of the fireplace, then slide until it fits into location.
2. Place 2 legs (2) and joints (3), then tighten the screws (1).
3. Place the 2 legs (5) and joints (6), then tighten the screws (4).

### MOUNTING OF THE MOBILE GLASS

1. Remove the removable plate (9) by unscrewing the screws (8).
2. Place the sliding glass (10) in the rails.
3. Replace the removable plate (9) and tighten the screws (8).

## OPERATION & USER GUIDE

**OPERATING THE WOOD BURNER WITH THE DOOR OPEN EXPOSES YOU TO MULTIPLE HAZARDS (FALLING EMBERS, SMOKE EMISSIONS IN THE ROOM, ETC.). ALWAYS OPERATE THE APPLIANCE WITH THE DOOR CLOSED.**

### PRECAUTIONS FOR THE FIRST IGNITION - CURE WITH 10 SMALL FIRES

The first ten fires should be light, moderate and not overly loaded with wood. We recommend a small fire consisting of 3-4 logs weighing around 3kg in total. Remember to open the flue damper control prior to lighting a fire.

**NOTE:** The flue damper must be opened while the fireplace is in operation. The flue damper must only be closed when the fireplaces is not in operation.

### PAINT

It is strongly recommended that no person(s) come into contact with the external faces of the appliance without the protective gloves provided, this will avoid any 'marking' on the paint surface prior to it being cured. The paint will polymerise after several fires. Do not scrub or clean the fireplace with any rough surface (such as a sponge). In the case of accidental scratches, make several fires until the paint is cured, at which time you can delicately clean the outside of the appliance with a hot sponge. Do not scratch or rub the fireplace while it is lit. It is recommended contact with the fireplace should be kept to a minimum. Do not paint the fireplace using products NOT recommended by the supplier, please contact your authorised dealer should you require further assistance.

**Avoid scratches and markings on your appliance by not placing any objects on your appliance during operation and when not in use.**

### VENTILATION

A strong burning smoke odour may be smelt during the first several fires, it is therefore recommended to ventilate the premises by opening windows/doors in order for the paint to cure. This phenomenon will disappear after these initial burns cycles.

### LIGHTING THE FIRE

The fire is started with the airways open (except Tatiana 997). Open all airways to allow maximum air intake. In order to limit smoke emission, it is preferable to use the inverted or top-down fire lighting method (see illustration below). An initial load of 3kg of wood can provide a sufficient layer of embers.

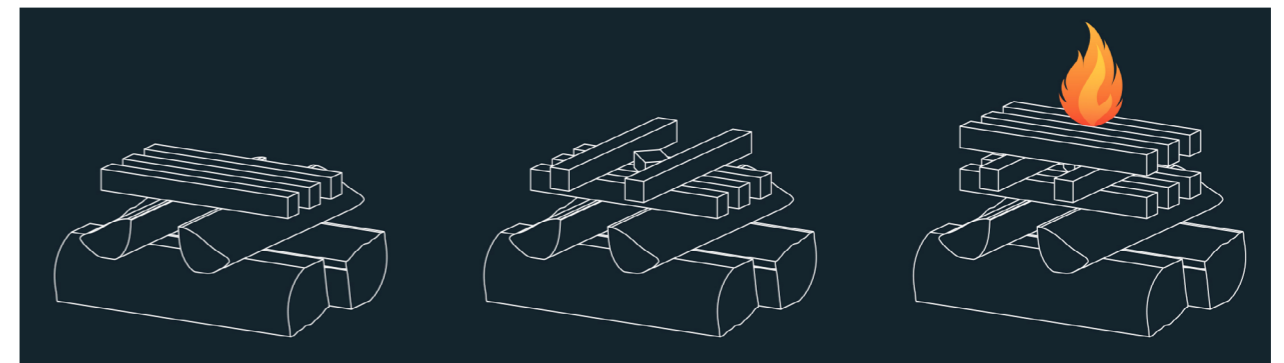

### IGNITION INSTRUCTIONS

Before any ignition ensure the primary air is open in order to accelerate combustion and evacuate the fumes. This adjustment should then be reduced as the fire has stabilised in order to maintain a longer fire term and avoid any possible overheating. The door of the fireplace should be closed in order to avoid any risk of back-flow.

Always slowly and gradually light the fire; split wood and fire starters are recommended. It is strictly forbidden to use any volatile substances including; methylated spirits, gasoline, solvents or the likes as these will result in a risk of explosion or thermal shocks by a sudden rise of temperature.



## OPERATION & USER GUIDE (CONTINUED)

### IGNITION INSTRUCTIONS (continued)

After an extended time of non-use, it is recommended that the firebox be checked and cleaned by a professional to ensure there is no obstruction in the flue and no blocking of the manoeuvring members (damper) before ignition.

### DAMPER CONTROL

When preparing the unit for use (ignition and wood loading), it is important that the damper is in the open position. While the unit is functioning ensure the damper is in the open position. Once the fire has extinguished, close the damper.

**NOTE:** The flue damper must be opened while the fireplace is in operation. The flue damper must only be closed when the fireplace is not in operation.

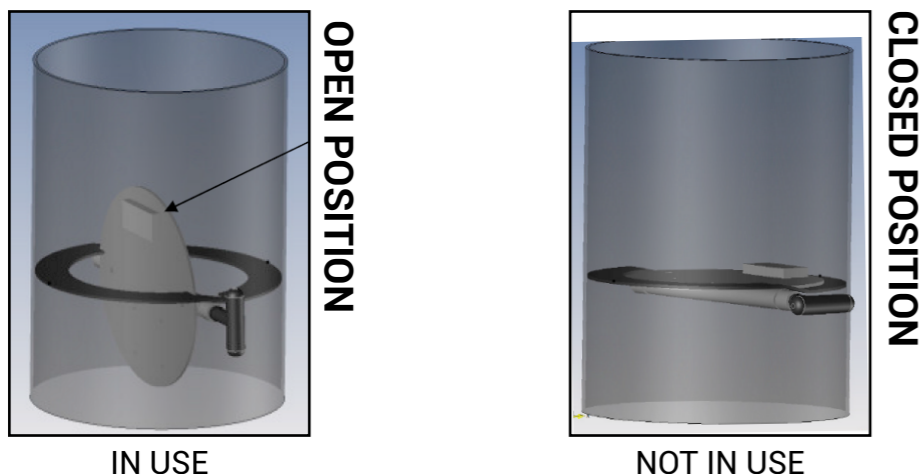

### COMBUSTION AIR SETTINGS

The combustion air control is located on the base below the fireplace shelf. This mechanism controls flow of air entering the firebox, which allows for a more precise control of the fire. The quantity of combustion air entering the firebox can be altered by moving the combustion air control from the left (low) to the right (high).

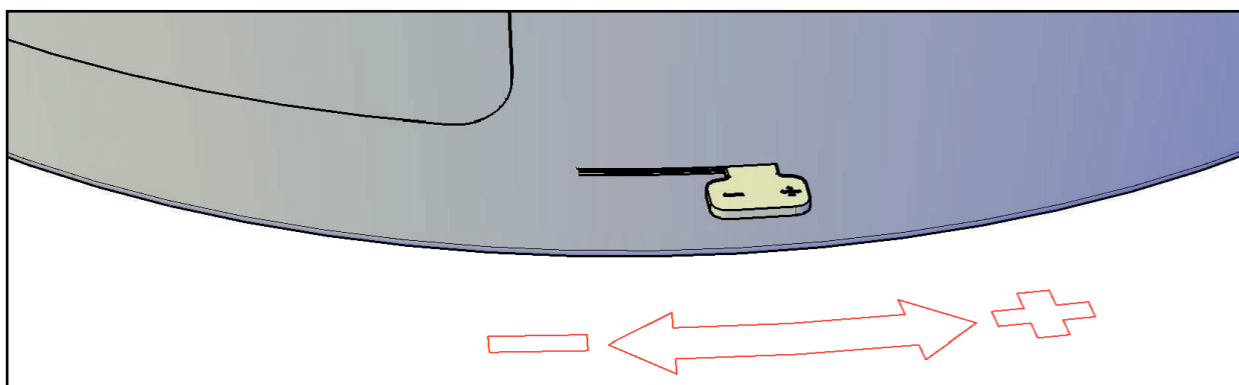

### ACCELERATED COMBUSTION

The maximum heat output for JC Bordelet fireplaces is achieved with the combustion air control fully opened. The fireplace can achieve an optimal heat output with two large or three medium size pieces of wood.

### MEDIUM COMBUSTION

This is the recommended mode for operating JC Bordelet fireplaces as it will deposit the least amount of creosote on glass panels and in the flue. The combustion air control should be set to half-open after ignition. The most efficient setting will vary depending on many factors including flue length and the moisture content of the wood. Two large or three medium size pieces of wood should be burning over a bed of hot coals.

## OPERATION & USER GUIDE (CONTINUED)

### SLOW COMBUSTION

When the air combustion control is nearly closed, the fireplace is in its slowest combustion phase. If the fire is hot enough, slow combustion will not stop the fire, but there will be a noticeable change in the flame pattern. The flames will be slow and may appear dirty if the wood is too wet (moisture content of 15% and more). This method of operation is not recommended and will produce excessive creosote in the fireplace and the flue. **Creosote may also accumulate on the glass panels.**

**CAUTION:** Continuous and intensive slow burn operation may cause early deterioration of the appliance and its components, as well as a chimney fire if the flue has not been regularly cleaned.

### ESTABLISHING THE FIRST FIRE

Before establishing the first fire, remove all labels or equipment parts located in the ash box or in the furnace. Open the flue damper control.

While building your first fire, keep the combustion rate at a moderate level to ensure that the sealant binds with the paint. All materials should be seasoned.

**Please note:** Before building a big fire, establish several fires. The curing process is necessary to ensure that the paint is not damaged and that the insert is well seasoned.

Do not overload the furnace. The optimum amount of fuel should not exceed one third of the insert volume. Before reloading, make sure that the fire has subsided. This will keep the fireplace from over-firing.

Flow of air can be regulated by the primary air controls at the front of the unit.

Except for the short time required to build a fire, the fireplace door should be fully closed. If doors are left partly open, flue gas may be drawn out of the opening creating risks from both fire and smoke.

### IMPORTANT

Ventilation devices which operate with the fireplace on the same premises or on the premises which share the same ventilation shaft may not function properly.

Please ensure the grate is never blocked.

During installation please allow for access to have the fireplace and the connecting shaft cleaned.

If required, install cut-off and stifling devices.

### RECOMMENDED FUEL

This fireplace is designed for wood fuel only. Any fuel other than wood is strictly forbidden. As a general rule it is recommended; use dry, well-seasoned **HARD WOOD** with a 15% moisture content or less in order for the unit to burn effectively and avoid any tarring. The heating output of wood depends on the moisture percentage.

### AVERAGE WOOD DRYING TIME BASED ON MOISTURE CONTENT

|              | C   | L   |             | C   | L   |
|--------------|-----|-----|-------------|-----|-----|
| DIRECTLY CUT | 75% | 78% | 1 YEAR      | 33% | 35% |
| 3 MONTHS     | 48% | 62% | 1 1/2 YEAR  | 18% | 27% |
| 6 MONTHS     | 37% | 46% | 2 YEARS     | 16% | 24% |
| 9 MONTHS     | 36% | 38% | 2 1/2 YEARS | 15% | 24% |

**C: Chunks L: Logs**

## OPERATION & USER GUIDE (CONTINUED)

### RECOMMENDED FUEL

If the wood is piled up loosely, it will burn faster because the necessary oxygen for the combustion will easily reach every piece of wood. This piling is recommended if you want to heat over a short period of time. When the wood is piled more compact, it will burn slower as the combustion air cannot reach all the logs at the same time. This piling is recommended if you want to heat over a longer period of time.

### ATMOSPHERIC CONDITIONS

Misty or foggy weather may possibly favour back-flow of the smoke, which may be a health hazard. In this case only use the fireplace as is necessary.

**For safety reasons, assemblies of appliances and accessories not provided or recommended by Bordelet or Sculpt Fireplaces are NOT PERMITTED. Unsuitable equipment may affect the functionality of the fireplace and can be dangerous in certain situations.**

### EXTINGUISHING THE FIRE

Stop fuelling the fire and let it burn out. The fire should burn out without any constraints. Do not close the air slides before the fire is completely extinguished, otherwise it may release noxious gases.

**CAUTION:** Do not hang or install objects within 2m of the appliance. This includes paintings, photos, televisions, and any other combustible material.

### IMPORTANT WARNING

**Storing any flammable materials (paper, linen, furniture, solvents, flammable liquids, spray containers, gas bottle, etc.) close to the fireplace is strictly forbidden.**

**All these products should never be stored even for a short while in wood storages or recesses laid out under or near the appliance.**

**CAUTION:** The window, the front panel of the appliance, as well as all external faces including the facade, will attain high temperatures (above 100°C). Uninitiated persons, young children and infants should be monitored at all times while in the vicinity of the appliance.

### TRANSITION PERIOD, INSUFFICIENT CHIMNEY DRAUGHT AND POOR WEATHER CONDITIONS

Pay attention to the operations of the insert during transition periods and/or when chimney draught is insufficient or when weather conditions are unfavourable, especially during severe cold weather. Such conditions may cause flue gas to flow into the room. To prevent such a situation, you should reduce the intensity of fire by curbing the influx of air into the combustion chamber until smoke disappears. Afterwards you may increase air flow monitoring for any appearance of smoke in the room.

## MAINTENANCE

Before the first fires in autumn we strongly recommend cleaning the top of the appliance to prevent carbonising the dust that could then be deposited on the convection grate.

### CLEANING THE GLASS

The window of the fireplace requires regular cleaning with specific products intended for this use. The use of moist hard wood with a moisture content above 15% causes excessive creosote build up on the glass. Once again we recommend only burning very dry hard wood.

## MAINTENANCE (CONTINUED)

### CLEANING THE GLASS (CONTINUED)

We recommend waiting for the glass to cool before cleaning it. The use of products that are too aggressive (eg. abrasive cleaners) may lead to the deterioration of some of the wood heater parts. An effective and ecological method of cleaning the glass is to use a piece of damp newspaper dipped in ash and then rinsing with clean water. You can also use a commercially available glass cleaning product.

### FLUE & FIREBOX

Flues should be professionally cleaned and checked twice a year, including at least once during the peak period of use and more if required. A professional should also check seals, door ropes, baffle plates and all consumable parts of the firebox and flue to ensure the unit is in safe working order.

### DO NOT REMOVE THE BAFFLE EXCEPT WHEN PERFORMING A CHIMNEY SWEEP

**CAUTION:** Cracked and/or broken components (eg. glass panels or baffles) may render the installation/operation unsafe. Do not use the appliance if this is the case and contact your dealer.

### ASH PAN

The ash pan should be emptied regularly in order to avoid any overflow and clogging of the fire grate. You will find some ashes catching in the cavities between the ribs of the fireplate. This bed of ashes caught between the fireplate is essential as it will create a more effective start up operation of the fire.

### FORBIDDEN FUELS

This appliance is not designed for burning the following fuels:

- Solid mineral fuels (all coals or similar)
- Liquid mineral fuels (Gasoline, fuel oil, solvents, drainage oils or similar)
- Methylated spirit
- Creosote-treated woods and too moist or green woods
- Paper or cardboard
- Wood workshop residues (Shavings, saw dusts or similar)
- Other forbidden fuels that may harm the appliance or the environment

### CHIMNEY SWEEPING

It is necessary to perform a chimney sweep and ensure it's clear of any build up (creosote, bird's nest, etc). Chimney sweeps should be performed twice a year, including at least once during the period of use.

### CHIMNEY FIRES

Chimney fires can be caused due to incorrect use of the appliance and lack of periodic cleaning.

Visible signs of a chimney fire include:

- Abundant fumes
- Strong smell of soot
- Roaring in the flue
- Significant increase in the temperature of the flue
- Cinders flying out of the top of the flue

## MAINTENANCE (CONTINUED)

### CHIMNEY FIRES (CONTINUED)

Suggested course of action in case of chimney fires:

1. Put out the fire by carefully removing the glowing logs and fully close the fireplace door.
2. Use a chimney sieve screen (metal mesh 2 x 10mm, preferably brass, on a 60x60cm frame). Place the screen on the chimney top and inspect the lower parts for cracks through which fire flames may escape. A hot screen reduces the draught in the chimney and, consequently, slows down the soot burning process.
3. If required, call the Fire Department.

**In the event of any emergency, put out the fire immediately by cutting off airflow and, where necessary, cover glowing wood with sand. Try to remove fuel from the hearth.**

**Do NOT use water to put out the fire as it may cause permanent damage.**

### TROUBLESHOOTING AND COURSE OF ACTION TO PUT OUT THE FIREPLACE IN THE EVENT OF AN EMERGENCY.

**NOTE:** These course of actions are only recommendations. For more detailed information contact your dealer or licensed technician

| Symptoms   | Possible cause   | Proposed course of action  |
|--|--|--|
| 1. Smoke comes from the fireplace  | <ol style="list-style-type: none"> <li>1. Air supply ventilation is choked</li> <li>2. Size of chimney shaft or its length is not sufficient</li> <li>3. Fault location of chimney relevant to roof ridge</li> <li>4. No chimney cap installed</li> <li>5. Improper connection of insert with smoke shaft</li> <li>6. Chimney not clear</li> </ol> | <ol style="list-style-type: none"> <li>1. Provide a clear ventilation shaft</li> <li>2. Extend chimney</li> <li>3. Extend chimney</li> <li>4. Mount chimney cap</li> <li>5. Apply reducer between fireplace insert and smoke shaft</li> <li>6. Call authorised specialist</li> </ol>                 |
| 2. Ash comes from the fireplace  | Too much ash in ash box  | Remove ash from ash box, clear grate   |
| 3. Glass becomes dirty   | Improper firewood used (too much resin, too wet or wood from coniferous trees) or inadequate draught in chimney  | Use special cleaning agent or clean ash from fireplace. If inadequate draught, see other troubleshooting suggestions.  |
| 4. Starting a fire is a problem or fire is weak  | <ol style="list-style-type: none"> <li>1. Logs too thick</li> <li>2. Wood too wet</li> <li>3. Ash box full</li> <li>4. Chimney cold</li> <li>5. Air supply installation malfunctions</li> <li>6. Chimney not clear</li> </ol>  | <ol style="list-style-type: none"> <li>1. Use recommended fuel</li> <li>2. Use seasoned firewood</li> <li>3. Remove ash from ash box, clear grate</li> <li>4. Heat up chimney by burning more paper</li> <li>5. Provide or clear ventilation shaft</li> <li>6. Call authorised specialist</li> </ol> |
| 5. Fire is too strong  | <ol style="list-style-type: none"> <li>1. Fireplace door open</li> <li>2. Too strong draught in chimney</li> </ol>   | <ol style="list-style-type: none"> <li>1. Close door</li> <li>2. Install draught regulator</li> </ol>  |
| 6. Movable part is damaged in use (grate, baffle board, rear panel, side panels, glass plate, seals) | Parts subjected to normal wear and tear need to be replaced (not covered by warranty - see warranty terms and conditions)  | Buy new spares from the dealer (dealers information can be found on the website: <a href="https://sculptfireplaces.com.au/stockists/">https://sculptfireplaces.com.au/stockists/</a> )   |

## TEST REPORTS

### BORDELET APPLIANCE OUTPUT TEST

|                       |  |
|-----------------------|--|
| TESTING LABORATORY    | HRL Technology   |
| MANUFACTURER          | JC BORDELET  |
| MODEL                 | EVA 992   TATIANA 997   ZELIA 908   LEA 998  |
| ISSUE DATE            | 17.11.2015 (EVA & LEA)   18.11.2015 (ZELIA & TATIANA)  |
| INVESTIGATING OFFICER | Steve Marland  |
| RESULTS               | The maximum carbon dioxide output of the EVA 992 / TATIANA 997 / ZELIA 908 was performed at the high burn rate prescribed in AS/NZS4013 (2014) gave a maximum carbon dioxide output of 3.2% (by volume). And 2.8% (by volume) for the LEA 998. |

### CONCLUSION

Based on this result, exemption from testing the EVA 992 / TATIANA 997 / ZELIA 908 / LEA 998 solid fuel appliance should be claimed under section 1.2.3 (f) of AS/NZS4013 (2014) as the maximum carbon dioxide output from combustion is less than 5% by volume when fired at the prescribed high burn rate.

## TEST REPORTS

### BORDELET APPLIANCE OUTPUT TEST

|                       |  |
|-----------------------|--|
| TESTING LABORATORY    | ASFT   |
| MANUFACTURER          | JC BORDELET  |
| MODEL                 | LINEA 914  |
| ISSUE DATE            | 31.10.2017   |
| INVESTIGATING OFFICER | Steve Marland  |
| RESULTS               | The maximum carbon dioxide output of the LINEA 914 was performed at the high burn rate prescribed in AS/NZS4013 (2014) gave a maximum carbon dioxide output of 3.2% (by volume). And 2.8% (by volume) for the LEA 998 and EVA 992. |

### CONCLUSION

Based on this result, exemption from testing the LINEA 914 solid fuel appliance should be claimed under section 1.2.3 (f) of AS/NZS4013 (2014) as the maximum carbon dioxide output from combustion is less than 5% by volume when fired at the prescribed high burn rate.

## WARRANTY

JC Bordelet fireplaces are guaranteed for 5 years. This excludes the ash pan, ash grates, fire grate retainers and baffles which are guaranteed for 1 year. Glass is not covered under any warranty.

The warranty becomes effective at the date of purchase.

### WARRANTY DOES NOT COVER

1. Door seals, ropes, gaskets and glass
2. Any form of rust and/or corrosion to the painted finish of the heater
3. Salted air of a coastal region or a highly humid environment may contribute to some oxidation of the steel, in this case the warranty is therefore not valid for damages originating from these causes
4. All defects or faults resulting from poor maintenance, inappropriate use or a non-compliant installation which does not abide by Australian & New Zealand Standards AS/NZS 2918:2018 or instructions are listed in this manual are not warranted
5. Any device or accessory not provided by JC Bordelet or Sculpt Fireplace Collection are strictly forbidden and will result in a void of all warranties by the manufacturer and distributor
6. No modifications can be made to the firebox or to original components supplied with the appliance
7. The manufacturer and distributor are by no means responsible for any indirect damage originating from a handling accident
8. Cost of removal of a defective heater or re-installation of a replacement heater
9. Any glass breakage can only result from poor assembly, impact or incorrect use of the appliance. Glass is not covered under warranty.

### PERFORMANCE

The performance of our fireplaces are given as an indication and comparison after testing under optimum conditions. These values reported under standard conditions may be subject to variations if the installation and conditions of use are not equivalent to our testing conditions. In any case, the fireplace remains an extra heater and should not replace a main heating system.

### WARRANTY CLAIMS

Any defects / faults resulting from negligent maintenance, poor installation practices, altering or repair of the appliance not recommended by the supplier or inappropriate use of the appliance, are excluded from being covered under the warranty.

In the case of a faulty part, the user should immediately inform the authorised dealer.

For all warranty claims, we will require photos, proof of purchase, serial number and the date of installation along with the compliance certificate from your licensed installer.

The guarantee is strictly limited to the exchange or repair by ourselves of parts agreed to be defective, without exception. Costs of dismantling, assembly and transport will under no circumstance be covered by this warranty, the manufacturer, distributor and should be handled between the user and installer.

## WARRANTY CARD

|  |
|--|
| <b>DATE OF PURCHASE</b>  |
| <b>PLACE OF PURCHASE</b>   |
| <b>DATE OF INSTALLATION</b>                                      |
| <b>COMPLIANCE CERTIFICATE NO.</b>                                |
| <b>MODEL NO.</b>   |
| <b>NAME AND ADDRESS OF PURCHASER</b>                             |
| <b>PHONE NO.</b>   |
| <b>EMAIL ADDRESS</b>   |
| Please include a copy of your receipt and compliance certificate |

EMAIL OR POST WARRANTY INFORMATION TO  
 info@sculptfireplaces.com.au  
 PO Box, 1232 Mornington, VIC 3931  
 1300 851 304

**JC BORDELET**  
 créateur d'harmonie



Sculpt Fireplace Collection is an Australian owned company who exclusively supply some of world's most sought after **high-end luxury fireplaces.**

Intent on providing Australians with a dynamic collection of designer fires, Sculpt fireplace collection has strategically gathered not only award winning fireplace designs, but also fireplaces that have been manufactured with high quality materials and the best raw steel that is built to last.

**Our wood fire manufacturers integrate innovation, technology, environmental impact, operational expertise and quality, whilst holding design at the forefront. We aim to fill homes with the maximum of comfort while capturing the true art and meaning of a sculptural fireplace in any living space.**



JC BORDELET  
créateur d'harmonie

SEGUIN  
DUTÉRIEZ

Sculpt is proud to be the sole importer of Seguin, Axis and Bordelet fireplaces, with exclusive distribution rights throughout Australia and New Zealand.

Whilst every effort is taken to avoid errors, SCULPT FIREPLACE COLLECTION cannot accept responsibility for the accuracy of any statement, extract or information contained within this manual nor can any of its contributors who have submitted material for inclusion. SCULPT FIREPLACE COLLECTION may change or update this manual and anything described in it without notice. We will endeavour to ensure that information, materials and data on this site are complete, accurate and up-to-date. Information on this manual is for guidance only and cannot cover all circumstances. (E&OE)



SCULPT<sup>TM</sup>  
FIREPLACE  
COLLECTION