

Models:

Rinnai 650 Gas Fire (RDV600ER)

Rinnai 750 Gas Fire (RDV700ER)

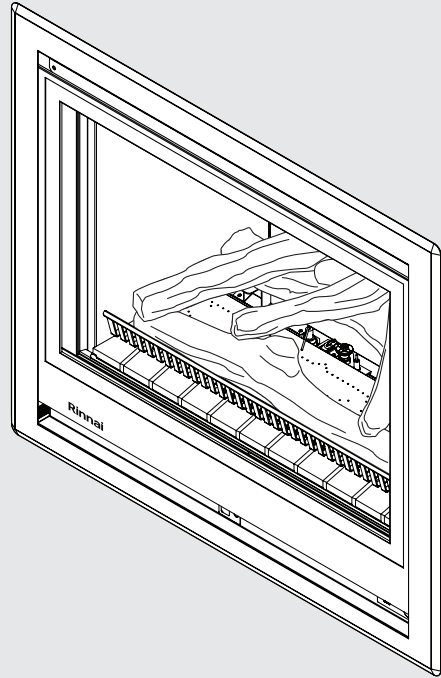
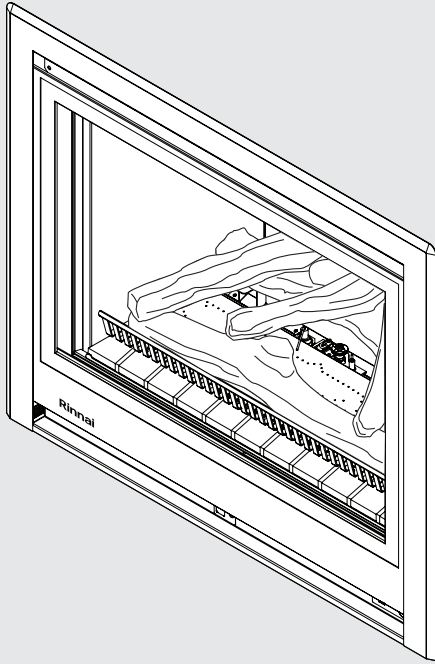

Gas Fireplace

Installation Manual

Rinnai

Congratulations on the purchase of your Rinnai 650 or 750 Gas Fire. We trust you will have many years of comfort and enjoyment from your appliance.



BEFORE USING THIS APPLIANCE

Before proceeding with the operation or installation read this manual thoroughly and gain a full understanding of the appliance, to ensure safe and correct use.

This version of the Installation Manual supersedes and replaces combined Operation & Installation Manuals Part Number: 12891 Issue 10 (April 2019) and all previous issues.

For details on how to use this appliance refer the Operation Manual Part Number: 12902.

This appliance must be installed in accordance with:

- Manufacturer's Installation Instructions
- Current AS/NZS 3000, AS/NZS 3500 & AS/NZS 5601
- Local Regulations and Municipal Building Codes including local OH&S requirements

This appliance must be installed, maintained and removed **ONLY** by an Authorised Person.

For continued safety of this appliance it must be installed and maintained in accordance with the manufacturer's instructions.



The Australian Gas Association
All Rinnai gas products sold in Australia are A.G.A. certified.

TABLE OF CONTENTS

Warnings & Important Information	5
Before Using or Installing This Appliance	5
Regulatory Information	5
Notice to Victorian Consumers	5
Dress Guard Warnings	5
Mandatory Inspection Prior To Installation	5
Modifications	6
General Safety Warnings	6
Before You Start	7
Installation Requirements	7
Certification	7
General Installation Information	8
Location	8
Additional Installation Information	9
Framing	10
Enclosure Requirements	10
Masonry Fireplace Installation	10
False Fireplace Installation	10
Enclosure Dimensions	11
Gas Supply	12
Installation of Consumer Piping	12
Purging Gas Supply	12
Leak Testing the Connection	12
Supply Connections	12
Electrical Supply	13
Socket Outlet	13
Direct Wired Installations	13
Flueing	14
Flue Installation Options	14
Flue Installation Options	14
Flue Components	15
Basic Flue Kits	16
Additional Flue Components	16
Flue Installation Dimensions & Restrictions Flue Terminal Clearances	17
Flue Terminal Clearances (extract from AS/NZS 5601)	18



This appliance **MUST** be installed, maintained and removed **ONLY** by an Authorised Person.
For continued safety of this appliance it **MUST** be installed and maintained in accordance with the manufacturers instructions.

INSTALLATION TABLE OF CONTENTS

Installation	19
Masonry Installation	19
Flue Installation Options	19
False Fireplace Installation	21
Connecting Gas	25
Connecting The Gas Supply	25
Leak Testing	25
Burner Media Installation	26
Ceramic Log Set Installation	26
Ceramic Stone Set Installation	28
Commissioning	29
General Information	29
Commissioning The Appliance For Different Gas Type	32
Attaching Fascia Assembly	33
Burn Media Installation	34
Abnormal Flame Pattern	34
Specifications	35
Table 1. Appliance Details	35
Table 2. Dimensions	36
Wiring Diagram	37
Contacts	40



This appliance **MUST** be installed, maintained and removed **ONLY** by an Authorised Person.
For continued safety of this appliance it **MUST** be installed and maintained in accordance with the manufacturers instructions.

WARNINGS & IMPORTANT INFORMATION



BEFORE USING OR INSTALLING THIS APPLIANCE

Before proceeding with the operation or installation read this manual thoroughly and gain a full understanding of the appliance, to ensure safe and correct use.

Failure to carefully read and follow all instructions in this manual can result in equipment malfunction, fire or explosion, property damage, personal injury and/or death.

DANGER: Indicates an imminently hazardous situation which, if not avoided, will result in personal injury or death.

WARNINGS: Indicates a potentially hazardous situation which, if not avoided, could result in personal injury or death.

CAUTIONS: Indicates a potentially hazardous situation which, if not avoided, could result in minor or moderate injury or damage to the appliance. It may also be used to alert against unsafe practices.



REGULATORY INFORMATION

This appliance shall be installed in accordance with:

Manufacturer's Installation Instructions.

Current AS/NZS 3000, AS/NZS 3500 & AS/NZS 5601.

Local Regulations and Municipal Building Codes including local OH&S requirements.

This appliance has been certified by the Australian Gas Association. The A.G.A. Certification Number is shown on the data plate.

This appliance **MUST** be installed, maintained and removed **ONLY** by an Authorised Person.

For continued safety of this appliance it **MUST** be installed and maintained in accordance with the manufacturer's instructions.

NOTICE TO VICTORIAN CONSUMERS

This appliance **MUST** be installed by a person licensed with the Victorian Building Authority. **ONLY** a licensed person will have insurance protecting their workmanship.

So make sure you use a licensed person to install this appliance and ask for your Compliance Certificate. For further information contact the Victorian Building Authority on 1300 815 127.



DRESS GUARD WARNINGS

The guard is fitted to this appliance to reduce the risk of fire or injury from burns and no part of it should be permanently removed. For protection of young children or the infirm, a secondary guard is required.

The glass dress guard supplied with this appliance **MUST NOT** be permanently removed as it fulfils an operational safety function. Additional dress guards including free standing types may be used in conjunction with, but **NOT** replace, the dress guard supplied with this appliance.



MANDATORY INSPECTION PRIOR TO INSTALLATION

Immediately report any damage or discrepancies to the Supplier of the appliance. This appliance was inspected and tested at the time of manufacture and packaging, and released for transportation without known damage. Upon receipt, inspect the exterior for evidence of rough handling in shipment. Ensure that the appliance is labelled correctly for the gas and electrical supply, and/or other services it is intended to be connected to.

For safety and warranty purposes, appliances that may be damaged or incorrect **MUST NOT** be installed or operated under **ANY** circumstances. Installation of damaged or incorrect appliances may contravene local government regulations. Rinnai disclaims any liability or responsibility whatsoever in relation to the installation or operation of damaged or incorrect appliances.

Take care when opening or unpacking this appliance. Failure to do so may result in serious injury or product failure.

Check the label for the correct gas type (refer rating plate, inside the appliance). Refer to local gas authority for confirmation of the gas type if you are in doubt.



MODIFICATIONS

DO NOT MODIFY THIS APPLIANCE, modifying from original specifications may create a dangerous situation and will void your warranty. Failure to comply with these instructions could result in a fire or explosion, which could cause serious injury, death or property damage.

DO NOT modify the electrical wiring of this appliance.

If the power cord is damaged or deteriorated it **MUST** be replaced by an authorised person. Failure to do so may result in electric shock, fire, serious injury or product failure.

Improper installation, adjustments, service or maintenance can cause serious injury, death or property damage. Such work **MUST ONLY** be performed by an authorised person.



GENERAL SAFETY WARNINGS

This appliance is **HEAVY**, during installation the use of a mechanical lifting aid is recommended, noting that improper lifting may result in serious injury.

WARNING: This heater **MUST NOT** be used if any of the glass panels are damaged.

Flue terminal **MUST** always vent directly to outdoors. **DO NOT** extend the flue vertically or horizontally in ways other than prescribed in this appliance manufacturer’s installation instructions. **ONLY** the flue components specified by Rinnai **MUST** be used.

When considering installation ensure minimum clearances as follows are adhered to, refer Fig. 1.

Heat radiating from the front of this heater may over time affect the appearance of some materials used for flooring such as carpet, vinyl, cork or timber. This effect may be amplified if the air in the room contains cooking vapours, candle vapours and cigarette smoke, etc. To avoid this possibility, it is recommended that a mat or similar protective sheet be placed in front of the appliance, extending at least 750 mm in front of the dress guard. Refer to "Location" on page 8 for mantel clearances, additional installation information and warnings.

This appliance **MUST NOT** be installed where curtains or other combustible materials could come into contact with it. In some cases curtains may need restraining.

This appliance is **NOT** intended for use by persons (including children) with reduced physical, sensory or mental capabilities or lack of experience and knowledge, unless they have been given supervision or instruction concerning use of the appliance by a person responsible for their safety.

The appliance is **NOT** intended for use by young children or infirm persons without supervision. Young children and the infirm **SHOULD** be supervised at all times when in the vicinity of this heater while it is in operation.

The heater **MUST NOT** be located immediately below a power socket outlet.

A dedicated 230 V earthed 10 Amp power point must be used with this appliance.

Refer to local gas authority for confirmation of the gas type if you are in doubt.

Suitable **ONLY** for indoor installation.

DO NOT operate this appliance before leak checking hoses and gas cylinder connection.

This heater **MUST NOT** be used if either of the glass panels are damaged.

NOT to be connected to an LP gas cylinder located indoors.

Please keep this instruction booklet in a safe place for future reference. All dimensions referred to in these instructions are in millimetres, unless otherwise specified.

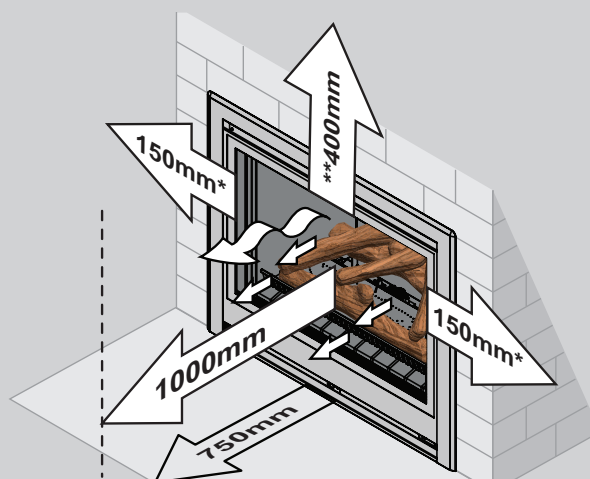

*150mm is the minimum clearance from edge of glass to combustibles.

**400mm is the minimum top clearance from edge of glass to combustible items other than mantel, overhanging 250mm or less. (Refer Mantel Clearance Table, page 9 and TV & Ornamentation Warning, page 10)

BEFORE YOU START

INSTALLATION REQUIREMENTS

This heater **MUST** be installed **ONLY** by an authorised person.

The installation **MUST** conform to local regulations.

The installation **MUST** also comply with the instructions supplied by Rinnai.

Service and removal **MUST** be carried out **ONLY** by an authorised person.

CERTIFICATION

The Rinnai 650 and 750 Gas Fires have been certified by the Australian Gas Association.

The AGA Certification Number is shown on the appliance data plate.

No parts or functions should be modified or permanently removed from the heater.

Please keep these instructions in a safe place for future reference.

CARTON CONTENTS / ITEM CHECKLIST

The components for Rinnai 650 and 750 Gas Fires are supplied in separate cartons, the following tables list which components are in each carton. Ensure that the components listed for the installation method being installed are present before proceeding with the installation.



The Engine, Fascia and Burner Media are packed into three separate cartons. One of each are required for all installation types.

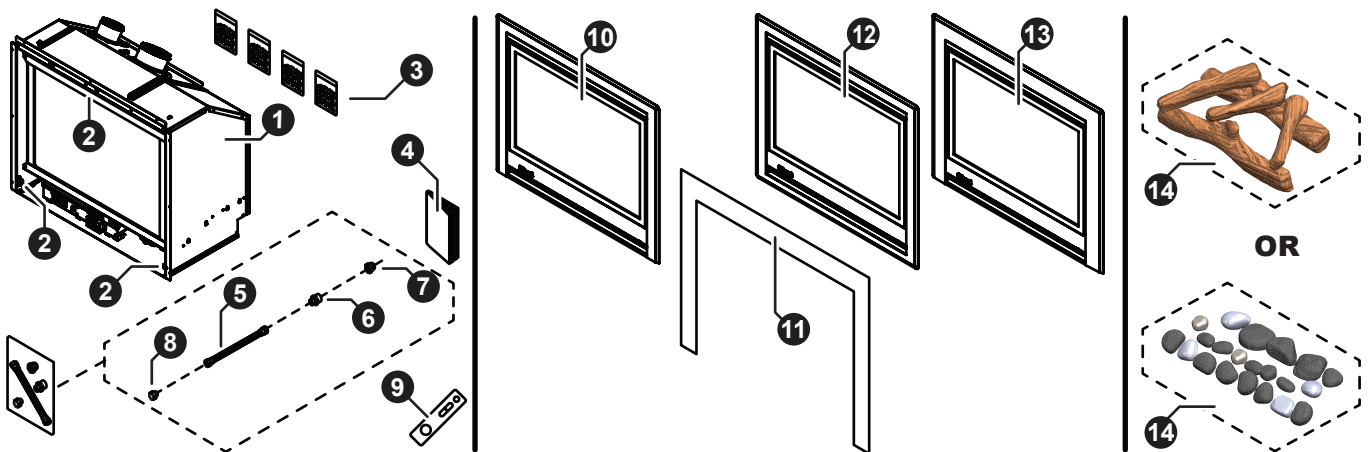

Major component descriptions and carton contents		Engine	Fascia Options			Burner Media
(1)	Rinnai 650 or 750 Engine (RVD600ER or RVD700ER).	●				
(2)	Fascia attachment screws (3 x 8g black, pre-fitted within the heater engine).	●				
(3)	Four Satchels - granule pack (x2), crushed glass (x1) and rockwool (x1).	●				
(4)	Operation and Installation manual.	●				
(5)	Semi rigid stainless steel gas pipe with 5/8" connections (x1).	●				
(6)	1/2" BSP - 5/8" UNF flared brass adaptors (x1).	●				
(7)	1/2" BSP Flared nut (x1).	●				
(8)	5/8" UNF Plug (x1).	●				
(9)	Remote Control, Infra Red (IR).	●				
(10)	Three sided fascia.*		●			
(11)	Three sided fascia infill (used to create an infill for masonry installations).			●		
(12)	Four sided fascia (used for elevated installations).*				●	
(13)	Three sided masonry fascia (alternative to infill, available for RVD700ER models Only).					●
*False fire place (Zero clearance) applications will require the use of a Zero clearance frame.						●
(14)	Ceramic log set OR Ceramic stone set, there is a different set of each for each model.					●

GENERAL INSTALLATION INFORMATION

LOCATION

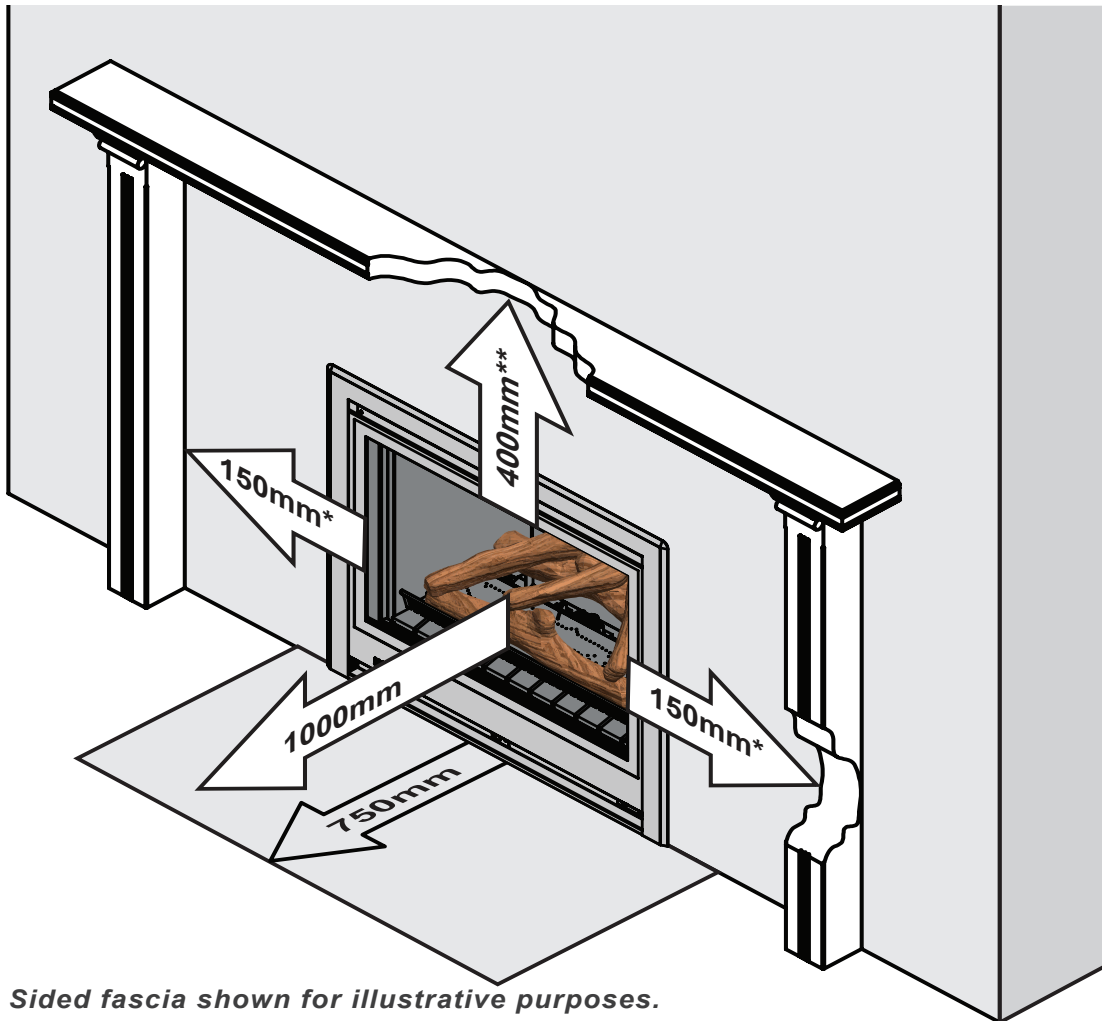

Sided fascia shown for illustrative purposes.

**150 is the minimum side clearance from edge of glass to combustibles.*

***400 is the minimum top clearance from edge of glass to combustible mantel with a depth of 250mm. (Refer Mantel Clearance Table on page 9)*

- When positioning the heater, the main variables governing the location are Flueing and Warm Air Distribution.
- This heater **MUST NOT** be installed where curtains or other combustible materials could come into contact with it. In some cases curtains may need restraining. **Refer to the warnings on page 6 for clearances to furnishings, adjacent walls, curtains and combustibles.**
- Mantels and surrounds can be added to complement the design provided that they conform to the clearances shown in the diagrams..
- The minimum clearance from the **edge of the appliance glass fascia** is 150mm on the sides and 300mm above.
- The depth of the mantel / surround at the minimum vertical clearance may not exceed 200mm
- An additional 100mm of vertical clearance is required for every extra 50mm of mantel depth, i.e. for a 300mm deep mantel the minimum vertical clearance is 500mm. This ratio applies incrementally to increases less than 50mm.

ADDITIONAL INSTALLATION INFORMATION

The diagrams below are to assist owners and installers in determining the clearance area around the fire without having the unit on site. The 4-sided frame is shown as this is used in mock chimney installations, which typically have mantels and surrounds made of combustible material. The 4-sided frame sits approximately 26mm below the engine. Refer to dimensions.

Rinnai 650 4-sided frame

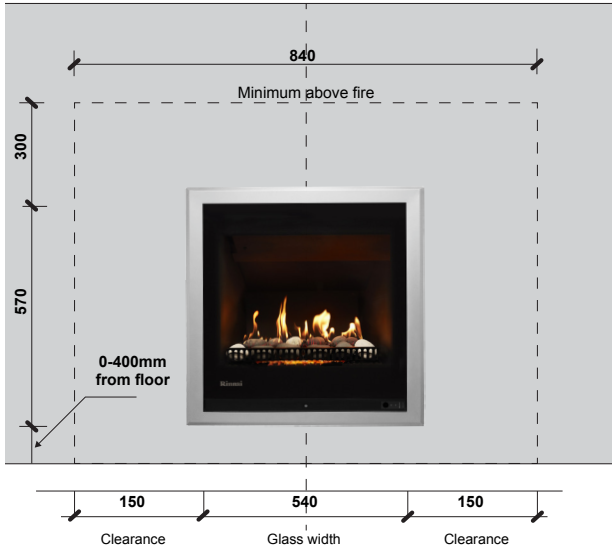

Rinnai 750 4-sided frame

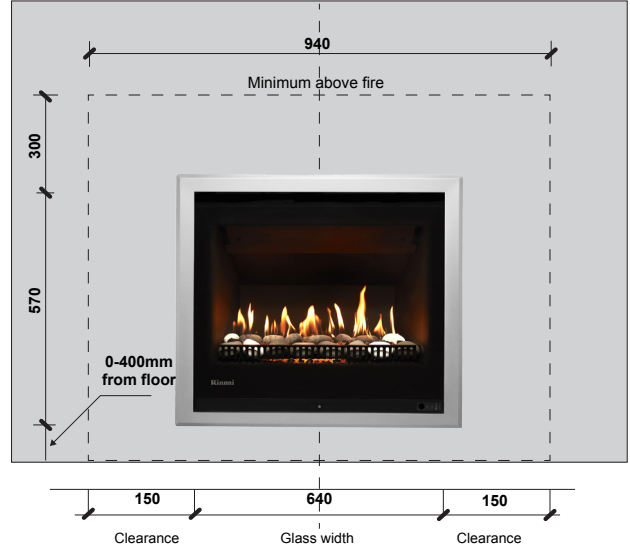

AT A GLANCE MANTEL AND SURROUND CLEARANCE CHART

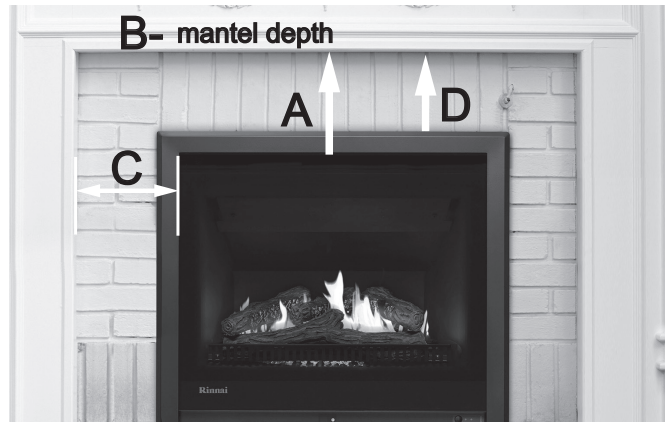

For every 50 mm of added mantel depth there must be an additional 100 mm of clearance from the edge of the glass

Depth of Mantel (B)	Minimum Clearance to Glass (A)	Minimum Clearance to Frame (D)
150	300	230
200		
250	400	330
300	500	430
350	600	530
400	700	630
Minimum Distance from Surround to Edge of Glass (C)		
150		
<i>All dimensions in mm</i>		

FRAMING

TV & ORNAMENTATION WARNING



INSTALLATION OF TV OR ORNAMENTATION ABOVE THE HEATER

The installation of electrical appliances above and in the vicinity of the heater such as, but not limited to, TVs, Home Theatre Screens, Speakers, etc., **MUST** comply with their manufacturer's instructions. It is the responsibility of the installer/end-user to check the installation instructions of these items and to ensure the location is suitable.

This caution also extends to, but is not limited to, ornaments such as: Paintings, Prints, Photographs, Tapestries, Mirrors, Stuffed Animals, etc.

Please note the recommended clearances in the diagrams above. Wall surface temperature may be elevated directly above the appliance and may discolour paint finishes or distort vinyl coverings. For durability of surfaces consult the relevant manufacturer's specification.



RINNAI DOES NOT TAKE ANY RESPONSIBILITY FOR ANY DAMAGE OCCURRING TO ANY ITEMS INSTALLED ABOVE AND IN THE VICINITY OF THE HEATER.



Use either a shelf or mantel below the TV or ornament or alternately you can construct a recess to mount TV or ornament in. Check the manufacturer's installation instructions for these items and ensure the recess is suitable.

ENCLOSURE REQUIREMENTS

Masonry Fireplace Installation

The appliance **MUST** be positioned within the fireplace on a flat level surface.

If the appliance is elevated from the ground within the structure, a base **MUST** be constructed using suitable material with supporting joists capable of supporting a minimum of 1.5 times the weight of the appliance.



In a masonry fireplace, use a slurry of sand and cement to level the base as required. Refer to page 21 and page 20 for "False Fireplace Elevated Installation"

False Fireplace Installation

Framework of the installation **MUST** conform to local building codes. Non-combustible materials need not be used. If the appliance is elevated from the ground within the structure, a base **MUST** be constructed using suitable material with supporting joists capable of supporting a minimum of 1.5 times the weight of the appliance.



AS/NZS 5601 "GAS INSTALLATIONS" requires that flue components be supported independently of the appliance.

ENCLOSURE DIMENSIONS

Enclosure dimensions are shown below. The enclosure dimensions specified are critical to the successful installation of this appliance and **MUST** be strictly adhered to.

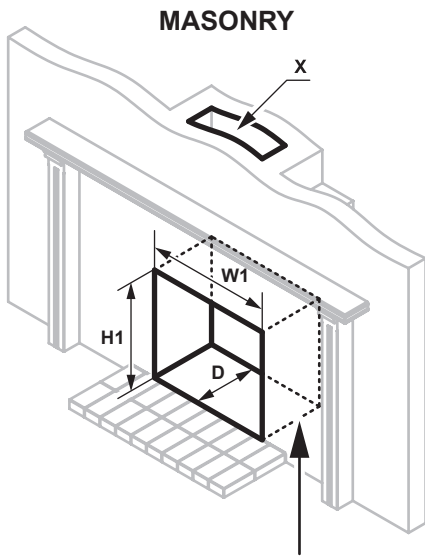

Level base with a slurry of sand and cement.

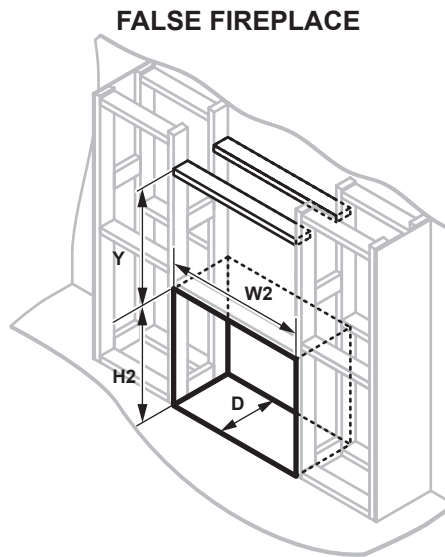

Refer to Elevated Installation section.

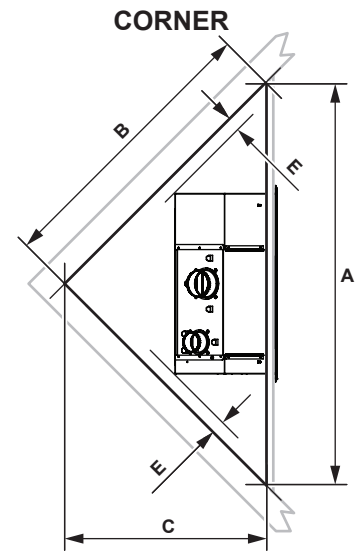

Minimum internal dimensions and clearances.

Models	Enclosure Type (All dimensions are minimums and are in mm unless otherwise stated)											
	Masonry				False Fireplace				Corner ‡			
	Height (H1)	Width (W1)	Depth (D)	Chimney (X)	Height (H2)	Width (W2)	Depth (D)	Support (Y)	Face (A)	Sides (B)	Depth (C)	Clearance (E)
RDV600ER	600	600	400 *	200 x 200	700 #	700 #	400 *	Max 600 §	1404	993	702	25
RDV700ER	600	700	400 *	200 x 200	700 #	800 #	400 *	Max 600 §	1504	1063	752	25



§ Framing **MUST** include supports for the mounting of the co-linear to coaxial flue adaptor.

The co-linear flexible flue **MUST NOT** come into contact with **ANY** combustible material.

The enclosure dimension for False Fireplace installations are larger, to make allowances for the fitment of the zero clearance frame. The fitment of this frame is necessary to provide the required clearances from any combustibles.



For clarity, the consumer piping gas supply, electrical connections have been omitted, refer to page 12 and page 13 for details. Construction details have also been simplified.

* As the heater engine is installed flush with the external surface, when preparing the cavity the minimum depth needs to be inclusive of the external cladding thickness for false fireplace installations. It is the installers responsibility that adequate clearance be provided between the heater engine and any electrical connections on the inside of a masonry fireplace.

‡ Corner installations use False Fireplace enclosure dimensions and framing specifications.

SUPPLY CONNECTIONS

GAS SUPPLY



Gas pipe sizing **MUST** consider the gas input to this appliance as well as all other gas appliances in the premises. The gas meter and regulator **MUST** be specified for the total gas rate.

A suitable sizing chart such as the one in AS/NZS 5601 should be used.

The use of rubber hose for any gas connection to a fixed appliance is **NOT** authorised by the manufacturer.



Confirm correct gas type (see labels located on top or rear panels). Refer to local gas authority for confirmation of gas type if you are in doubt.

Installation of Consumer Piping

The gas supply (consumer piping), termination is inside the heater and enters through the rear of the appliance.

Refer to the dimensional drawings on page 36 for appliance gas inlet location and other relevant dimensions.

Mark off the location for the vertical centre line **(1)** of the heater enclosure (inbuilt installations) or heater (freestanding installations).

To the right of the vertical centre line **(1)**, mark off both the vertical **(2)** and horizontal **(3)** location for the gas supply penetration (consumer piping). For measurements refer to the Gas Supply Dimension Table below.

The length of the gas supply (consumer piping) termination **(4)** is measured from the front of the enclosure.

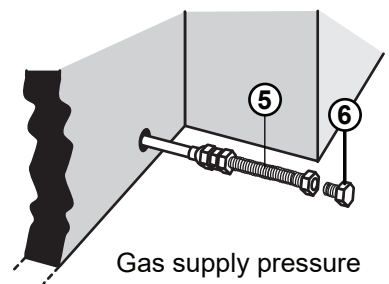
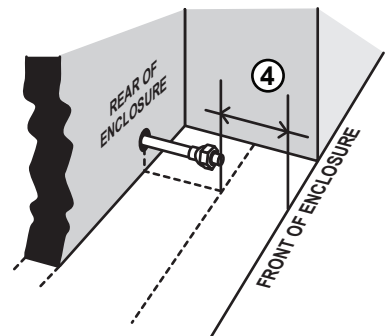
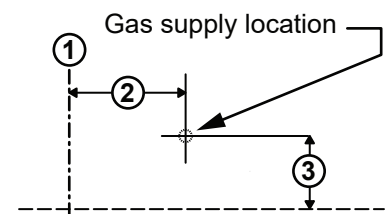

Gas Supply Dimension Table

	RDV600ER	RDV700ER
(2)	265 mm to the right of the appliance centre-line	312 mm to the right of the appliance centre-line
(3)	18mm from base of enclosure	
(4)	Consumer piping to be terminated 295 mm from the front of enclosure.	



For masonry fireplace installations:

Gas supply dimension **(4)** **MUST** include the thickness of an infill panel (when fitted). A standard Rinnai infill panel adds 2mm to the front of the enclosure.

For false fireplace installations:

Gas supply dimension **(4)** **MUST** include the thickness of the cladding to be used.

Once the consumer piping has been terminated to the above requirements the supplied flexible gas connection **(5)** may then be fitted.

Purging Gas Supply

Foreign materials and debris such as swarf, filings, etc. **MUST** be purged/removed from the gas supply, failure to do so may cause damage to the gas control valve causing it to malfunction.

Leak Testing the Connection

With the supplied plug **(6)** inserted into the end of the flexible gas connection, leak test all joints.



Use a soapy solution to test all gas connections. If a leak is present bubbles will form at the leak point. When finished remove any residue with a rag. Prevent any soapy solution from coming in contact with electrical components.

ELECTRICAL SUPPLY



HAZARDOUS VOLTAGE.
Risk of Electrical Shock.



Disconnect all
sources of supply
prior to servicing

**Socket Outlet**

Where a power point is used it **MUST** be 230 V, rated at 10A and **MUST** be earthed. This power point **MUST NOT** be located above the heater. Alternatively the appliance can be direct wired if the power supply is to be concealed.

The heater engine is fitted with a 1.5 m power cord and three pin plug (**7a**) which exits the appliance from the rear panel at the lower left.

Direct Wired Installations

Alternatively the appliance can be direct wired if so required.



A qualified electrician will need to be consulted where a direct wired installation is required.

Any such installation **MUST** comply with the requirements of AS/NZS 5601, AS/NZS 3000 and any other relevant local regulations.

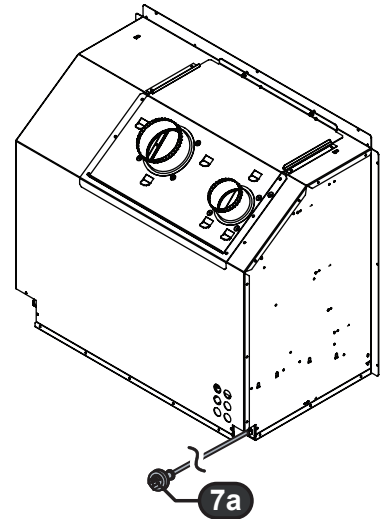

FLUEING

FLUE INSTALLATION OPTIONS



The following diagrams illustrate the flue installation options that are available for the RDV600ER and RDV700ER space heaters. **ONLY** the genuine Rinnai flue is certified as part of the space heaters installation requirements.

ONLY an authorised person **MUST** install, service and remove the Rinnai RDV600ER and RDV700ER space heater and flue system.

Only the flue system components described in this Manual are suitable and **MUST** be used. **‘DO NOT USE AN UNLINED MASONRY CHIMNEY AS THE FLUE FOR THIS APPLIANCE’.**

Components that are not described in that manual, whether manufactured by Rinnai or otherwise, are **NOT** compatible and **MUST NOT** be used.

Rinnai appliance warranty conditions may be voided if non Rinnai Flue Components are fitted.

AS/NZS 5601 “GAS INSTALLATIONS” requires that flue components be supported independently of the appliance.

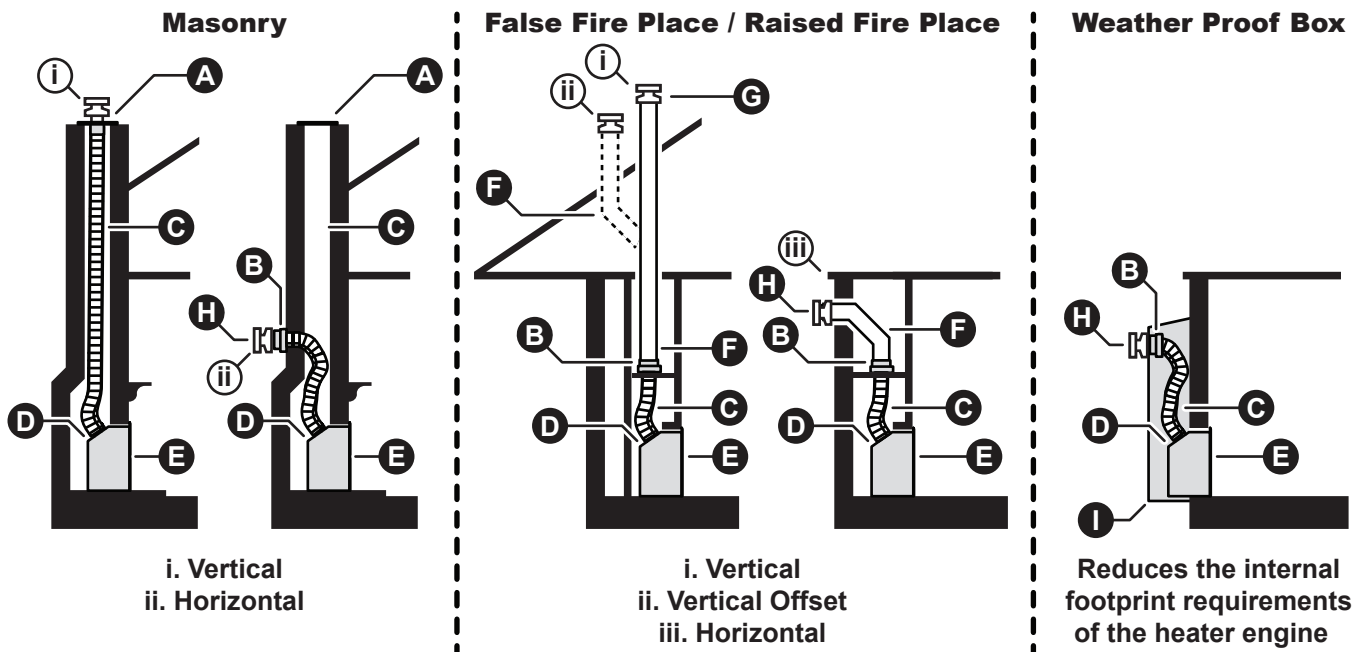

- (A) Masonry (Co-linear) cowl
- (B) Co-linear to coaxial adaptor & support plate/mount
- (C) Flexi pipes (100Ø exhaust / 75Ø air intake)
- (D) Spigot plate (this is part of the heater engine)
- (E) Heater engine
- (F) Coaxial pipe components (170Ø outer pipe, a max of 2 x 45° bends ONLY are allowed)
- (G) Vertical cowl
- (H) Horizontal terminal
- (I) Weather proof box.

FLUE COMPONENTS

RDVFF (RDV Flexi Flue)
For Masonry Installations **ONLY**

WARNING RDVFF is **NOT** suitable for combustible material constructions.

RDVFF Terminal Topside View

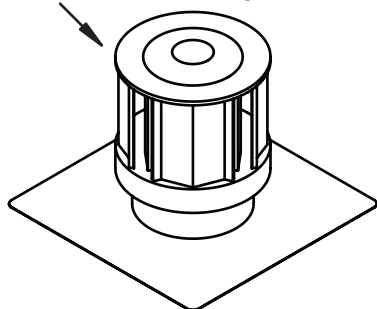

RDVFF Terminal Underside View

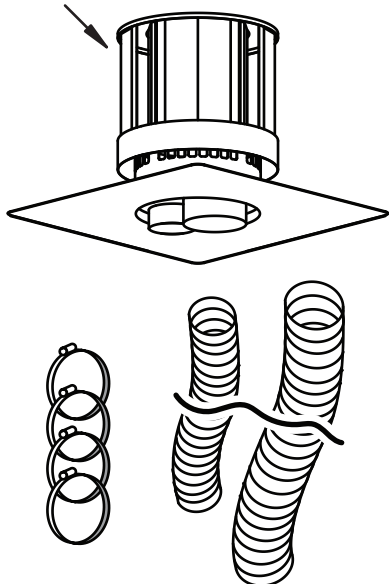

RDVFA (RDV Flue Adaptor)

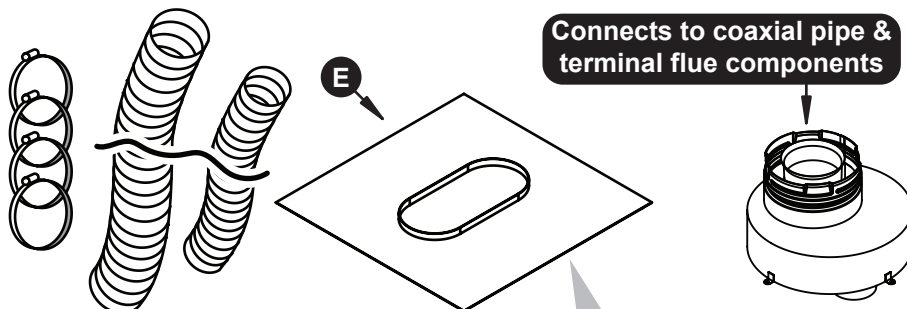

IMPORTANT The coaxial mounting plate (E), is used for vertical and horizontal **False Fireplace** installations **ONLY**. The coaxial mounting plate (E), may require cutting to size on some installations.

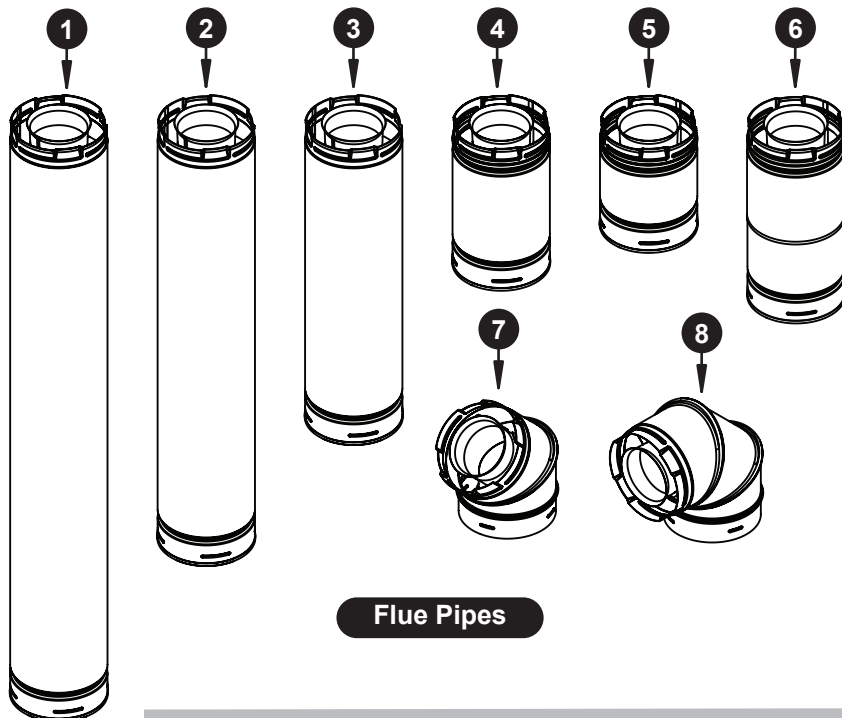

Flue Pipes

IMPORTANT Minimum and maximum flue length requirements **MUST** be observed, refer to page 15 for details.

IMPORTANT A horizontal masonry installation **MUST** use a horizontal masonry terminal mount (11) to affix both the co-linear adaptor (supplied with RDVFA) and the horizontal terminal (10) (supplied as an additional flue component) to the exterior wall.

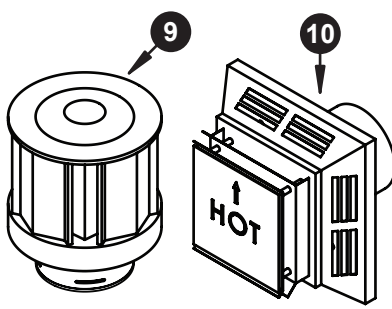

Flue Terminals

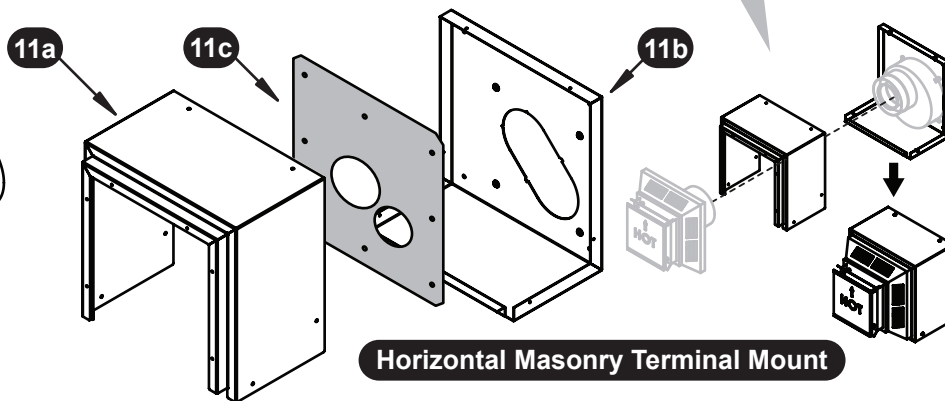

Horizontal Masonry Terminal Mount

BASIC FLUE KITS

RDVFF	Masonry chimney kit - RDV Flexi Flue 650/750. 2 x flexi pipes, 4x pipe clips and high wind terminal cap. <i>Rinnai Order Code: RDVFF</i>
--------------	--

 **RDVFF is NOT suitable for combustible material constructions.**

 **RDVFF- Masonry chimney flexi vertical flue kit extends out to 8m. Actual chimney size needs to be at least 200 x 200 mm for the flexi flues to fit down the chimney,**

RDVFA	False Fire place base kit - RDV Flue Adaptor 650/750. 2 x flexi pipes (Ø75mm & Ø100) , 4x pipe clips, co-linear to coaxial adaptor and coaxial mounting plate (455x455mm) (E) . <i>Rinnai Order Code: RDVFA</i>
--------------	--

 **A horizontal masonry installation will utilise the RDVFA as the basis for the installation.**
A horizontal masonry installation MUST use a horizontal masonry terminal mount (11) to affix both the co-linear adaptor (supplied with RDVFA) and the horizontal terminal (10) (supplied as an additional flue component) to the exterior wall.

 **RDVFA- False Fire Place base kit - RDV Flue Adapter extends out to 1.2m .**

ADDITIONAL FLUE COMPONENTS

- (1) Pipe length 48 inch - (1200mm), Rinnai Order Code: - RDV902
- (2) Pipe length 36 inch - (900mm), Rinnai Order Code: - RDV903
- (3) Pipe length 24 inch - (600mm), Rinnai Order Code: - RDV904
- (4) Pipe length 12 inch - (300mm), Rinnai Order Code: - RDV906
- (5) Pipe length 9 inch - (230mm), Rinnai Order Code: - RDV907
- (6) Adjustable Pipe Length 11 - 14 inch - (275 - 375mm), Rinnai Order Code: - RDV911 7
- (7) 45° Elbow, Rinnai Order Code: - RDV945G
- (8) 90° Elbow, Rinnai Order Code: - RDV990G
- (9) High Wind Terminal Cap (Vertical Cowl) - Rinnai Order Code: - RDV991

 **RDV991 may ONLY be used in conjunction with RDVFA (RDV Flue Adaptor). NOT suitable for use with RDVFF (RDV Flexi Flue).**

- (10) Square Horizontal Terminal Cap (Horizontal Terminal), (600mm), Rinnai Order Code: - RDV984
- (11) Horizontal Masonry Terminal Mount Kit - Rinnai Order Code: RDVHFS. This kit exists of three components:
 - (11a) = Mount Cowl Masonry
 - (11b) = Plate Chimney Mount and
 - (11c) = Template. (This template is used for the installation only, discard this template after use).

FLUE INSTALLATION DIMENSIONS & RESTRICTIONS FLUE TERMINAL CLEARANCES

Masonry Fireplace (Non-combustible ONLY)

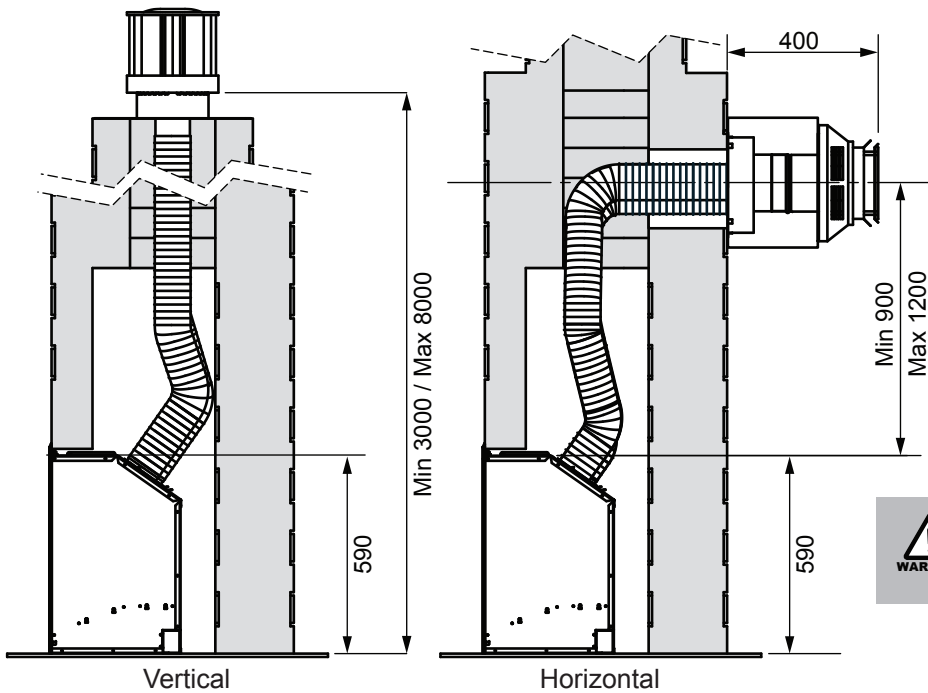

WARNING This method **NOT** suitable for combustible material constructions.

All dimensions in mm

False Fireplace

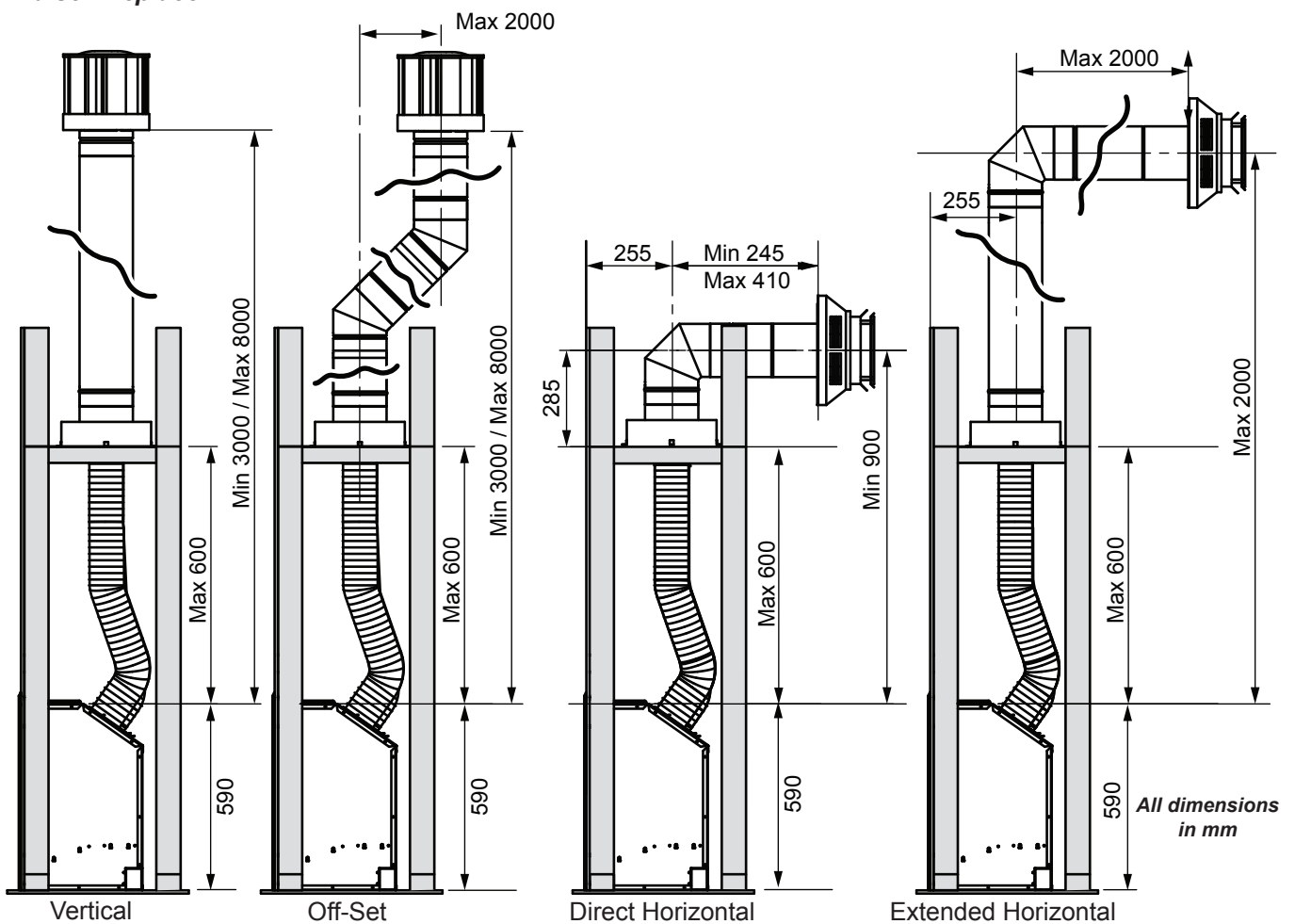

All dimensions in mm

FLUE TERMINAL CLEARANCES (EXTRACT FROM AS/NZS 5601)

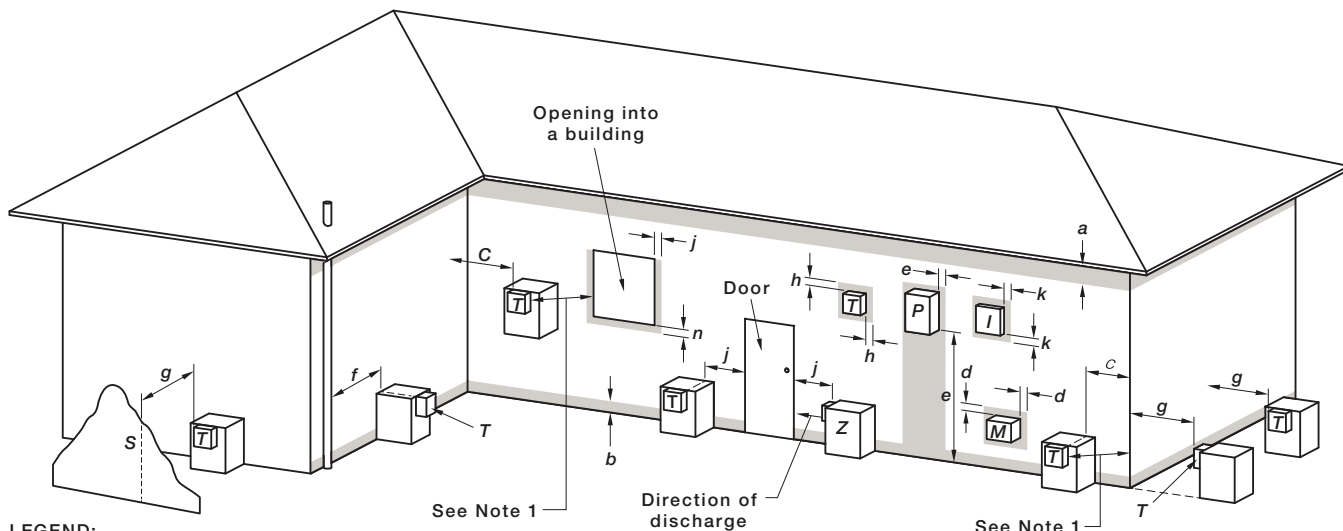

LEGEND:
 I = Mechanical air inlet
 M = Gas meter
 P = Electricity meter or fuse box
 S = Structure
 T = Flue terminal
 Z = Fan-assisted appliance only
 ■ Shading indicates prohibited area for flue terminals

Ref.	Item	Min. Clearances (mm)
		Natural Draught
a	Below eaves, balconies and other projections:	
	• Appliances up to 50 MJ/h input	300
	• Appliances over 50 MJ/h input	500
b	From the ground, above a balcony or other surface *	300
c	Front a return wall or external corner *	500
d	From a gas meter (M) (see 5.11.5.9 for vent terminal location of regulator) (see Table 6.6 for New Zealand requirements)	1000
e	From an electricity meter or fuse box (P) †	500
f	From a drain pipe or soil pipe	150
g	Horizontally from any building structure* = or obstruction facing a terminal	500
h	From any other flue terminal, cowl, or combustion air intake †	500
j	Horizontally from an openable window, door, non-mechanical air inlet, or any other opening into a building with the exception of sub-floor ventilation:	
	• Appliances up to 150 MJ/h input *	500
	• Appliances over 150 MJ/h input up to 200 MJ/h input *	1500
	• Appliances over 200 MJ/h input up to 250 MJ/h input *	1500
	• Appliances over 250 MJ/h input *	1500
	• All fan-assisted flue appliances, in the direction of discharge	-
k	From a mechanical air inlet, including a spa blower	1500
n	Vertically below an openable window, non-mechanical air inlet, or any other opening into a building with the exception of sub-floor ventilation:	
	• Space heaters up to 50 MJ/hr input	150
	• Other appliances up to 50 MJ/hr input	500
	• Appliances over 50 MJ/h input and up to 150 MJ/h input	1000
	• Appliances over 150 MJ/h input	1500

* - unless appliance is certified for closer installation
 † - Prohibited area below electricity meter or fuse box extends to ground level.

NOTES:

- Where dimensions c, j or k cannot be achieved an equivalent horizontal distance measured diagonally from the nearest discharge point of the terminal to the opening may be deemed by the Technical Regulator to comply.
- See Clause 6.9.4 for restrictions on a flue terminal under a covered area.
- See Figure J3 for clearances required from a flue terminal to an LP Gas cylinder. A flue terminal is considered to be a source of ignition.
- For appliances not addressed above acceptance should be obtained from the Technical Regulator.

FIGURE 6.2 (in-part) MINIMUM CLEARANCES REQUIRED FOR FAN-ASSISTED FLUE TERMINALS, ROOM-SEALED APPLIANCE TERMINALS AND OPENINGS OF OUTDOOR APPLIANCES

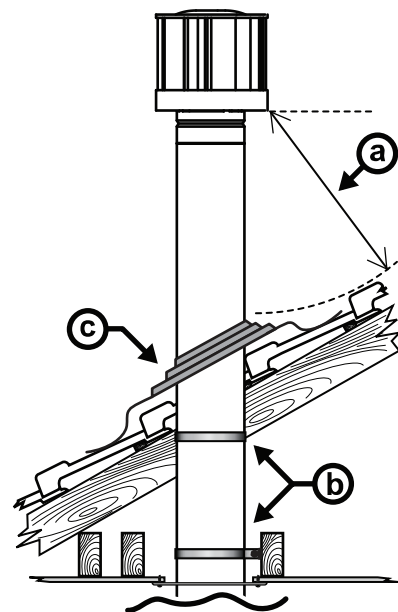

- (a) Minimum clearance 500 mm to nearest part of roof.
- (b) Minimum clearance 25 mm to combustible materials.
- (c) Decktite or lead collar flashing.



This appliance is a natural draft appliance and does not contain a combustion fan.

MASONRY INSTALLATION



Read this manual thoroughly and gain a full understanding of the requirements before undertaking installation. Ensure gas supply to heater is turned off for the first stages of this instruction.

FLUE INSTALLATION OPTIONS

- | | | | |
|--------|--------------------------------------|---------|--|
| Step 1 | Prepare Site – p. 19 | Step 7 | Insert Heater Engine Into Fireplace – p.20 |
| Step 2 | Unpack the Heater – p. 19 | Step 8 | Securing The Heater Engine – p.20 |
| Step 3 | Masonry Flue Installation – p.19 | Step 9 | CONNECTING THE GAS SUPPLY – p.25 |
| Step 4 | Positioning The Heater Engine – p.20 | Step 10 | LEAK TESTING – p.25 |
| Step 5 | Connect Electrical Supply – p.20 | Step 11 | BURNER MEDIA INSTALLATION – p.26 |
| Step 6 | Prepare Gas Supply – p.20 | Step 12 | COMMISSIONING INSTRUCTIONS – p.29 |

Step 1. Prepare Site



Ensure the intended enclosure meets the requirements of the dimensions as stipulated in “ENCLOSURE REQUIREMENTS” on page 10 and that gas and electrical supplies have been prepared in accordance with the dimensions stipulated in “GAS SUPPLY” on page 11 and “ELECTRICAL SUPPLY” on page 13.

In a masonry fireplace use a slurry of sand and cement to level the base as required.

Step 2. Unpack The Heater Engine

The heater engine is supplied in one carton, check to ensure you have all contents as listed under “BEFORE YOU START” on page 7 at the start of this manual before proceeding. Carefully remove carton by removing the straps and lifting the carton off the appliance. Remove all packaging materials and check all components for damage. If **ANY** damage is evident **DO NOT** install or operate this appliance. Contact your supplier for advice.



Retain the cardboard carton for use in the “Positioning The Heater Engine” on page 20.

Step 3. Masonry Flue Installation

Connect both the Ø 100mm exhaust pipe (A) and the Ø 75mm inlet pipe (B) flues to the masonry cowl (C1) / co-linear to coaxial adaptor (C2), noting that the larger diameter pipe is for the exhaust, securing both pipes to the cowl / co-linear to coaxial adaptor firmly with pipe clamps (D).

Feed the flexi-liner flue pipes down the chimney ensuring that exhaust pipe (A) is on the right when being viewed from the front of the fireplace. Once the pipe ends are accessible from fire place, the cowl / co-linear to coaxial adaptor components may then be secured and weather sealed in place.

At the fire place attach both exhaust pipe (A) and inlet pipe (B) flues to the engines spigot plate (E), noting again that the larger diameter pipe is for the exhaust, when viewed from the front this will be to the right. Secure both pipes to the spigot plate (E) firmly with pipe clamps (F).

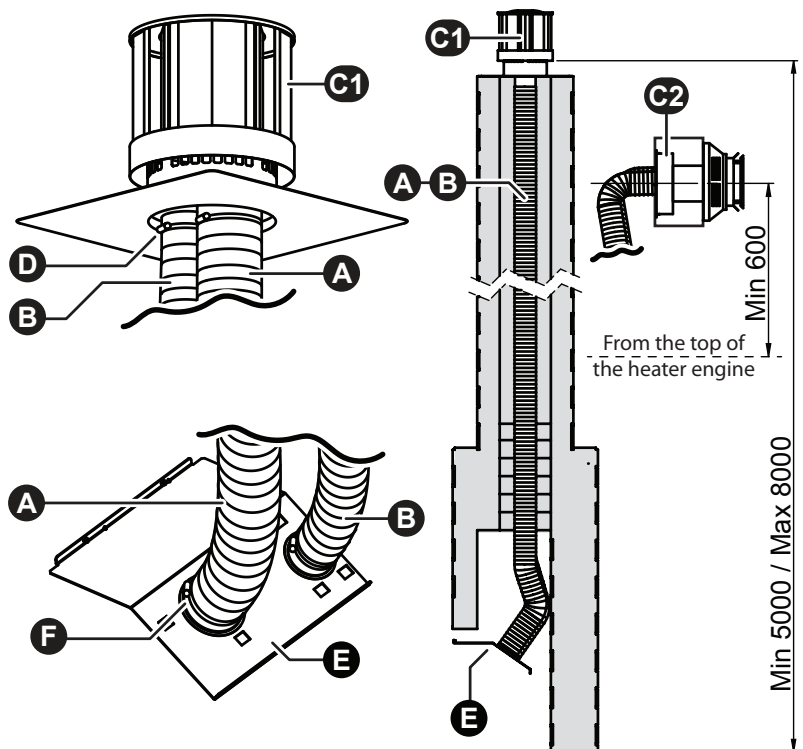

A horizontal masonry installation **MUST** use a horizontal masonry terminal mount to affix the co-linear adaptor and the horizontal wall terminal to the exterior wall

INSTALLATION

Step 4. Positioning the Heater Engine

Before installing the heater, check it is labelled for the correct gas type, (refer to the gas type label on the top body panel of the heater). Refer to the local gas authority for confirmation of gas type if you are in doubt.

Place the heater engine in front of the fireplace enclosure.



A panel from the cardboard packing carton placed on the floor underneath the heater will help prevent possible damage to flooring.

Step 5. Connect Electrical Supply

Ensure that the external isolation switch is OFF before connecting the power to the heater engine.

Step 6. Prepare Gas Supply

Remove the threaded brass plug from the S/S flexi pipe consumer gas supply pipe.

Step 7. Insert Heater Engine Into Fireplace

Position the heater engine so that the outer edges of the spigot plate (E) can be aligned with the guide rails (G) on top of the engine. Then carefully move the heater engine into the fireplace ensuring that the gas supply pipe and fittings (H) feed into the rear access hole and that the outer edges of the spigot plate (E) engage the guide rails (G).

Use two screw bolts (I) located in the upper flange of the heater to engage the nutserts installed in the front tab of the spigot plate (E).

Tighten these screw bolts, to pull the spigot plate (E) forward and allows the six locating / locking tabs (J) of the engine to engage the corresponding holes (K) of the spigot plate (E) and form a seal between the flue components and the engine.



Take care so that the electrical cord loosely coils up behind the heater engine to avoid pinching.

Step 8. Securing The Heater Engine

Fasten the heater to the masonry work using appropriate fasteners (not supplied) using the three holes across the top of the fascia assembly mounting panel and the 3 holes on each side of the side panels as shown (L).

Step 9. Connecting Gas

Continue to "CONNECTING GAS" on page 25.

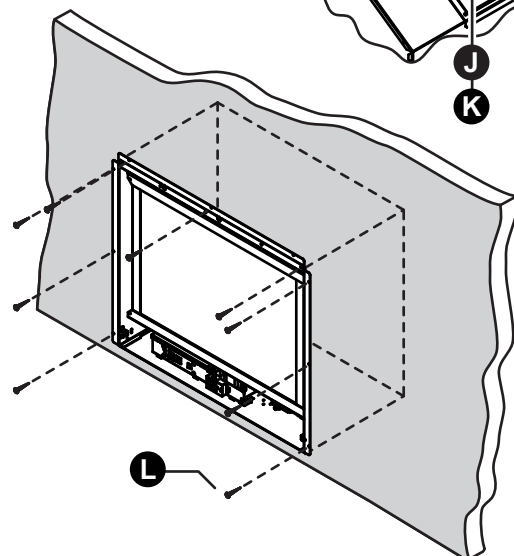
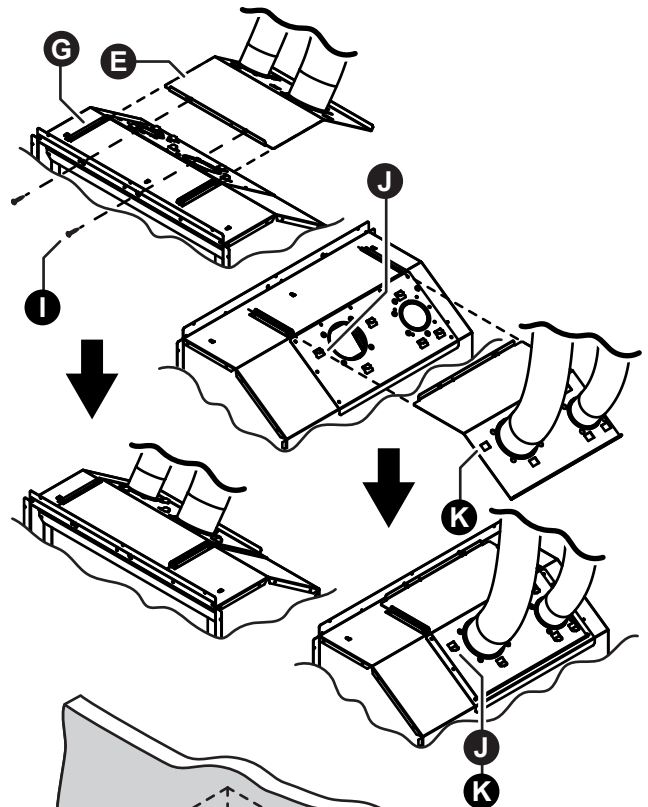
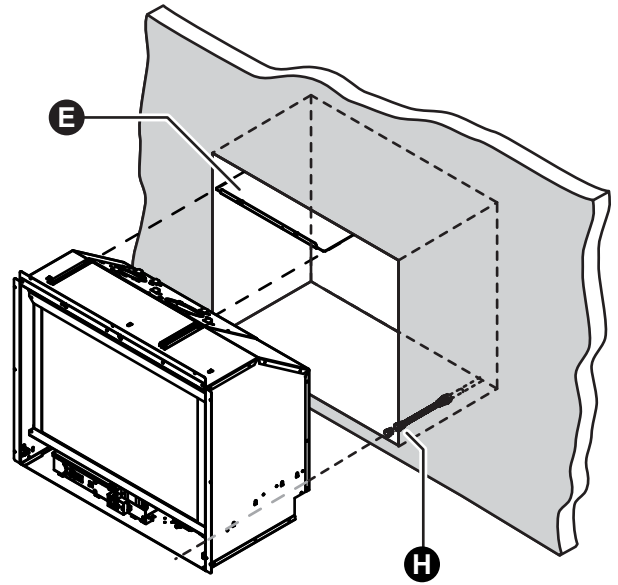

FALSE FIREPLACE INSTALLATION



When installing the Rinnai 650/750 into a purpose built mock chimney or chase, which is not open to the roof space of the building, you will need to add cavity vents.

Heat from the fire lost through the outer skin of the appliance and the flue system will not be able to adequately vent. This can lead to a build-up of excess heat in the cavity. In some cases the fire may overheat and the overheat safety mechanisms may operate.

Adding two vents of at least 200 cm² one at floor level and one at ceiling level, will allow adequate airflow in a cavity of approximately 1.2 m wide x 2.4 m high and 0.8 m deep. An additional benefit is that the ventilation of the cavity will return some of this heat into the room.



Read this manual thoroughly and gain a full understanding of the requirements before undertaking installation. Ensure gas supply to heater is turned off for the first stages of this instruction.

Step 1	Prepare Site – p.21	Step 8	Prepare Gas Supply – p.24
Step 2	Unpack The Heater Engine – p.21	Step 9	Inserting Heater Engine & Connecting Flue Spigot Plate – p.24
Step 3	Install Flue – p.22	Step 10	Securing The Heater Engine – p.24
Step 4	“Zero Clearance Frame Installation” – p.23	Step 11	CONNECTING THE GAS SUPPLY – p.25
Step 5	Install Cladding – p.23	Step 12	LEAK TESTING – p.25
Step 6	Positioning the Heater Engine– p.24	Step 13	BURNER MEDIA INSTALLATION – p.26
Step 7.	Connect Electrical Supply – p.24	Step 14	COMMISSIONING INSTRUCTIONS – p.29

Step 1. Prepare Site



Ensure the intended enclosure meets the requirements of the dimensions as stipulated in “ENCLOSURE REQUIREMENTS” on page 10 and that gas and electrical supplies have been prepared in accordance with the dimensions stipulated in “GAS SUPPLY” on page 11 and “ELECTRICAL SUPPLY” on page 13.

Ensure there are no wall studs, noggins, ceiling joists, wiring or other obstruction within the wall and or ceiling cavity where the flue is proposed to penetrate.

Step 2. Unpack The Heater Engine

The heater engine is supplied in one carton, check to ensure you have all contents as listed under “BEFORE YOU START” on page 7 at the start of this manual before proceeding. Carefully remove carton by removing the straps and lifting the carton off the appliance. Remove all packaging materials and check all components for damage. If **ANY** damage is evident **DO NOT** install or operate this appliance. Contact your supplier for advice.



Retain the cardboard carton for use in the “Positioning The Heater Engine” on page 24.

INSTALLATION

Step 3. Install Flue

Connect both the \varnothing 100mm exhaust pipe **(A)** and the \varnothing 75mm inlet pipe **(B)** flues to co-linear to coaxial adaptor **(C)**, noting that the larger diameter pipe is for the exhaust, securing both pipes to the co-linear to coaxial adaptor firmly with pipe clamps **(D)**.

Affix the coaxial mounting plate **(E)** with the flange fold upwards to the framing (max from top of heater height 600mm). Feed the flexi-liner flue pipes through the coaxial mounting plate **(E)** and down to the enclosure opening ensuring that exhaust pipe **(A)** is on the right when being viewed from the front of the opening, then secure co-linear to coaxial adaptor **(C)** to the coaxial mounting plate **(E)**.

Once the pipe ends are accessible from the opening, the adaptor and other flue components may then be secured in place and weather sealed where necessary

At the enclosure opening attach both exhaust pipe **(A)** and inlet pipe **(B)** flues to the engines spigot plate **(F)**, noting again that the larger diameter pipe is for the exhaust, when viewed from the front this will be to the right. Secure both pipes to the spigot plate **(F)** firmly with pipe clamps **(G)**.

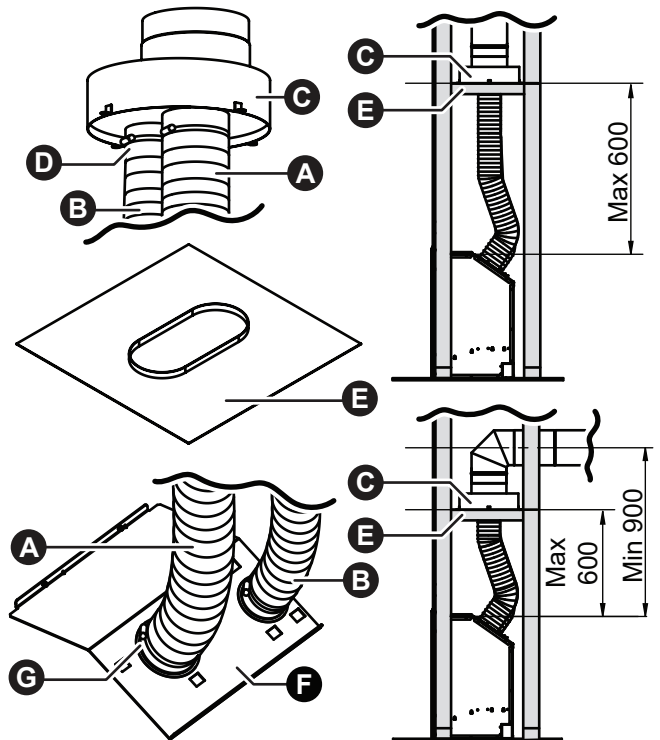

If pre-fitting flue prior to engine delivery, leave sufficient lengths of both the \varnothing 100mm exhaust pipe **(A)** and the \varnothing 75mm inlet pipe **(B)** within the enclosure opening. This will enable connection of the flues to the engine spigot plate **(F)** which is on the heater to be installed.

Step 4. Zero Clearance Frame Installation

A MDF, (Custom wood) board or equivalent of 20 mm thick, **MUST BE USED** in the base of the framework to support the heater engine.

The frame serves three purposes:

- Maintains the required clearances to combustibles around the fire
- Keeps the enclosure square and provides rigidity above the fireplace.
- Allows for a thin profile frame and for the engine to slip easily in and out of the enclosure

Carefully remove the contents from the carton and check to ensure you have all contents as listed in the instruction sheet supplied with the frame are present. If **ANY** damage is evident or parts are missing **DO NOT** assemble the zero clearance frame and contact your supplier for advice.

Assemble all four sides of the zero clearance frame (**H**) together in accordance with the instructions provided with the frame, noting that the frame can be assembled for the RVD600ER or RVD700ER using the same components.

Then secure the zero clearance frame (**H**) using the holes provided to the inside of the frame opening on the top (**I**) and on both sides (**J**) tabs using appropriate fixings (not provided).

Once the zero clearance frame (**H**) is secured in position remove the bottom frame component of the zero clearance frame (**K**) assembly as this part is only used to keep the frame square during installation and is no longer required.

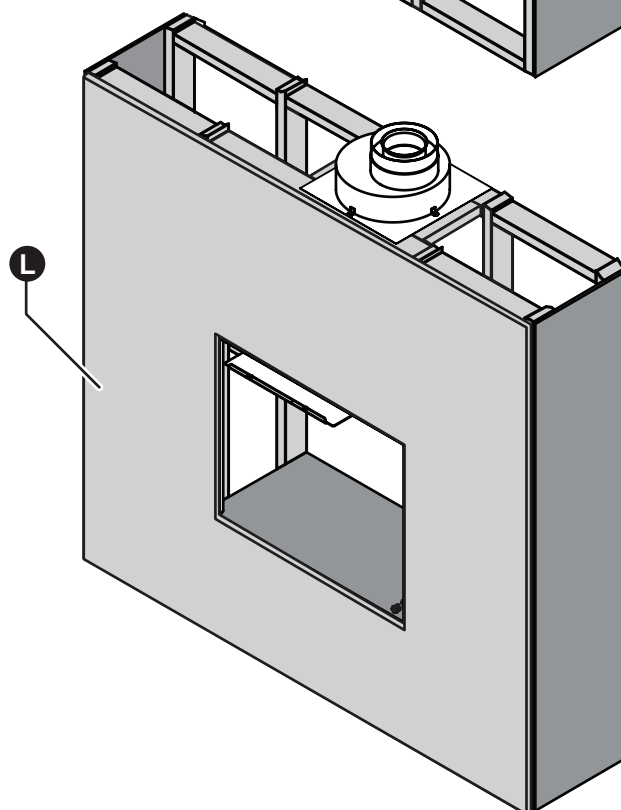
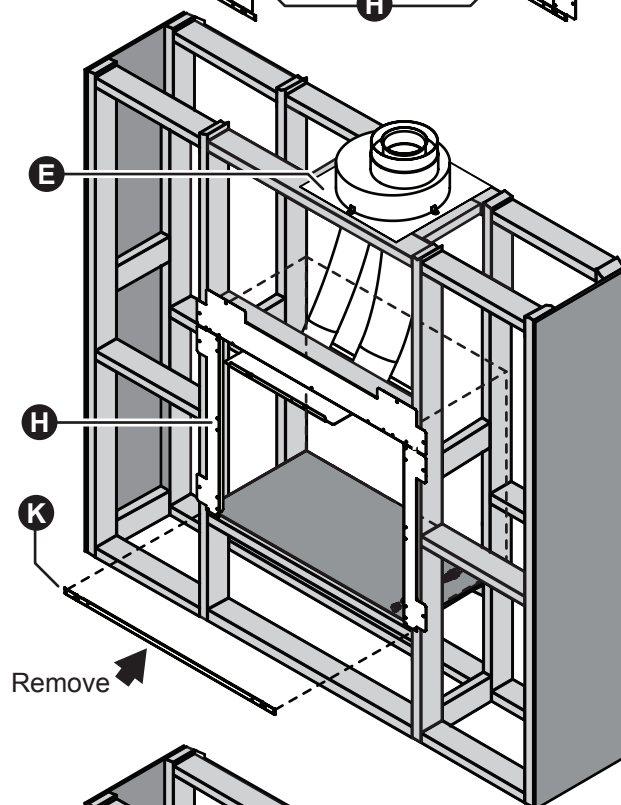
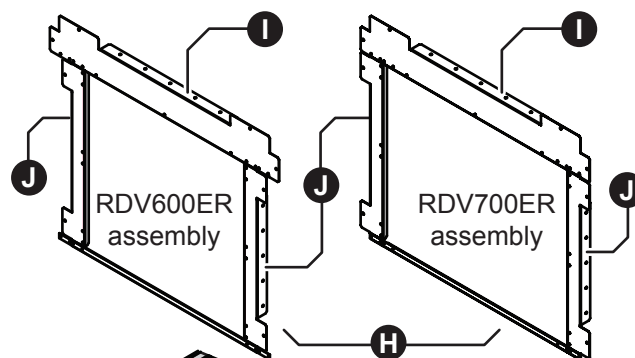

Step 5. Install Cladding



The *sheet wall cladding, (**L**), around the heater cavity **MUST** be installed in one complete section and attached to the frame as per the cladding manufacturer's specifications and requirements. This will avoid creating joints in the vicinity of the corners which may crack with normal operational expansion and contraction. Rinnai takes no responsibility in the event of such occurrences.

*Stone or ceramic tile type cladding reacts differently than plaster or board type claddings. Rinnai requires the installer to check with the product manufacturer for the suitability of their product for this application. Rinnai accepts no responsibility for the type of cladding chosen.

The cladding (**L**) may now be installed, ensuring that the cavity opening is cut flush to the inside edges of the zero clearance frame (**H**).



To assist with flue and electrical connections, if possible leave any side cladding of the false fire place open until the heater engine installation is finalised.

INSTALLATION

Step 6. Positioning the Heater Engine

Before installing the heater, check it is labelled for the correct gas type, (refer to the gas type label on the top body panel of the heater). Refer to the local gas authority for confirmation of gas type if you are in doubt.

Place the heater engine in front of the fireplace enclosure.



A panel from the cardboard packing carton placed on the floor underneath the heater will help prevent possible damage to flooring.

Step 7. Connect Electrical Supply

Ensure that the external isolation switch is OFF before connecting the power to the heater engine.

Step 8. Prepare Gas Supply

Remove the threaded brass plug from the S/S flexi pipe consumer gas supply pipe.

Step 9. Inserting Heater Engine & Connecting Flue Spigot Plate

Position the heater engine so that the outer edges of the spigot plate (F) can be aligned with the guide rails (M) on top of the engine. Then carefully move the heater engine into the fireplace ensuring that the gas supply pipe and fittings (N) feed into the rear access hole and that the outer edges of the spigot plate (F) engage the guide rails (M).

Use two screw bolts (O) located in the upper flange of the heater to engage the nutserts installed in the front tab of the spigot plate (F).

Tighten these screw bolts, to pull the spigot plate (F) forward and allows the 6 locating / locking tabs (P) of the engine to engage the corresponding holes (Q) of the spigot plate (F) and form a seal between the flue components and the engine.



On completion of heater installation **DO NOT** allow any portion of the 100mmØ exhaust flue to remain in contact with any combustible materials. Flue temperature may be hot enough to ignite certain materials.



Take care that the electrical cord does not bunch up or get pinched behind the heater engine while inserting the engine.

Step 10. Securing The Heater Engine

Fasten the heater to the masonry work using appropriate fasteners (not supplied) using the three holes across the top of the fascia assembly mounting panel and the 3 holes on each side of the side panels as shown (R).

Step 11. Connecting Gas

Continue to "CONNECTING GAS" on page 25.

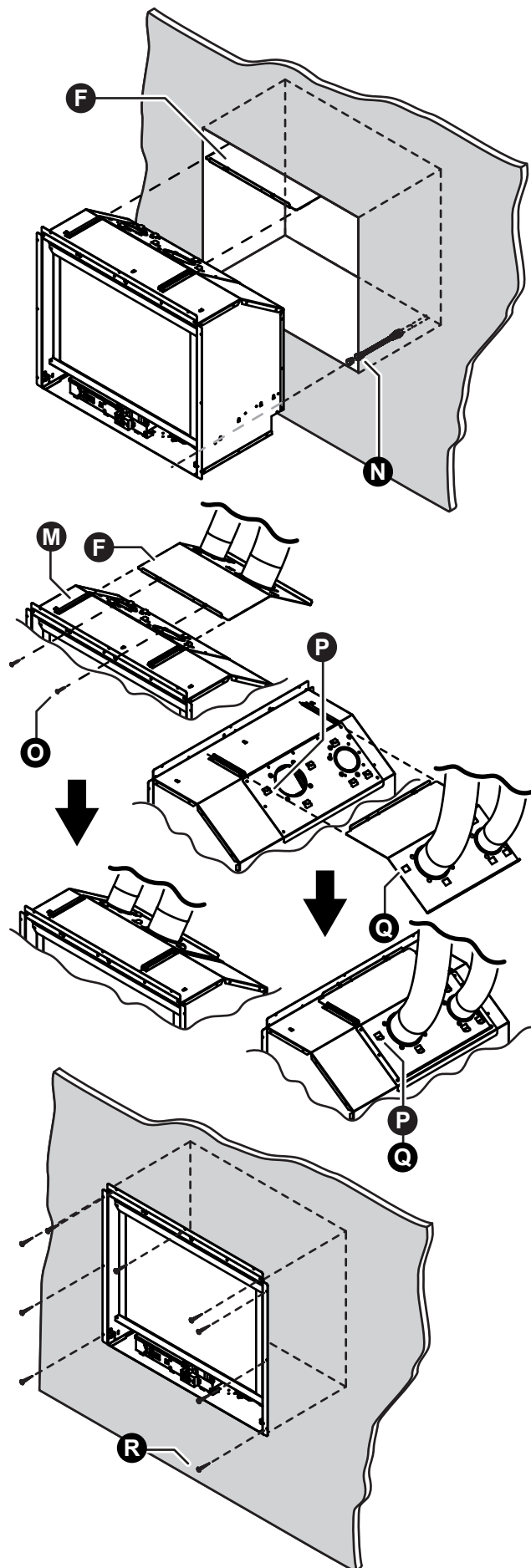

CONNECTING GAS

CONNECTING THE GAS SUPPLY

Firmly grasp the S/S flexi pipe **(A)** and bend at 90° approximately mid way to line up with the gas control valve inlet **(B)** then attach pipe to gas control valve and tighten. To assist there is a small spanner, located in the pouch that contains the commissioning instructions which is located on the top of the PCB cover **(C)**.

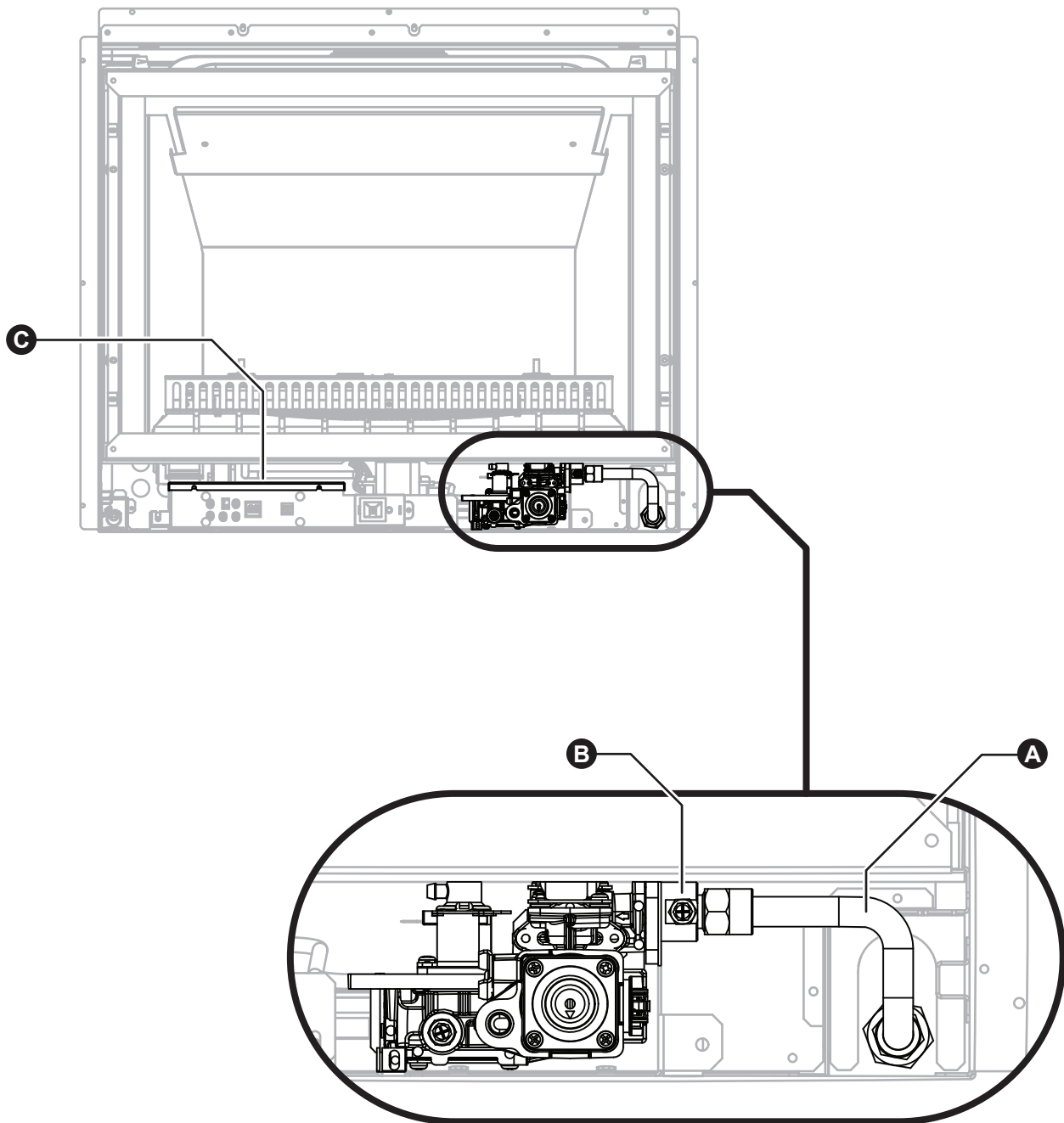

When the gas connection is completed, ensure that the spanner is returned to the commissioning instruction pouch, so that it can be available for the next installer / service person.

LEAK TESTING

Turn gas back ON and leak test appliance connection.



Use a soapy solution to test all gas connections. If a leak is present bubbles will form at the leak point. When finished remove any residue with a rag. Prevent any soapy solution from coming in contact with electrical components.

Continue to "BURNER MEDIA INSTALLATION" on page 26.

BURNER MEDIA INSTALLATION

CERAMIC LOG SET INSTALLATION

Carefully unpack and inspect each log for damage one at a time, temporarily returning each of the logs to the packaging for safe keeping until required. If **ANY** damage is evident on the logs **DO NOT** continue with installation and contact your supplier for advice.



For clarity the drawings are displayed without showing the entire heater.

Use extreme care when handling the Ceramic Log Set components, they are made from a very fragile high temperature material and will damage if handled roughly. Only remove the components from their packaging as required using the specific order as stated.

Step 1. Removing the Burner Box Glass



A set of instructions is attached to the burner box glass that has pictures of the suggested stone media placement, ensure to retain this instruction for use with "CERAMIC STONE SET INSTALLATION" on page 28.

While supporting the burner box glass panel in place (A), unscrew and remove the four retaining screws (B). Once unscrewed pull the burner box glass panel away and place it and the retaining screws safely aside where the glass and frame can not get damaged or the screws become lost.

Step 2. Burner Inspection

Check to ensure that the ports of the burner are clean and clear of any particles and all packaging material.

Step 3. Ember Bed Installation

Remove the stone guard (C), by unscrewing the three retaining screws, then gently lift the stone guard out, taking care to avoid scratching any of the interior surfaces or fittings.

Fill the perforated ember tray (D) evenly with the glass ember granules (E), then take between 6 to 8 pieces of the black burner granules (F) and spread these randomly over the glass layer of the ember bed.

When satisfied with the placement of the ember bed material, carefully re-fit the stone guard (C).

Step 4. REAR Log Installation

Identify the "REAR" log and then carefully remove it from the protective packaging.

Locate the two slots in the base of the log and carefully place these over the positioning pins (G) which are located at the rear of the burner box, ensuring that the detailed surface of the log is facing out to the front.

Artificial log set as supplied in protective packaging

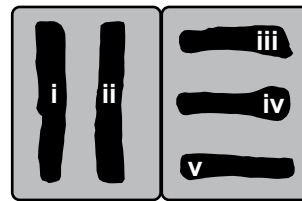

LOG	RDV600	RDV700
i	REAR	FRONT
ii	FRONT	REAR
iii	MIDDLE	
iv	RIGHT	
v	LEFT	

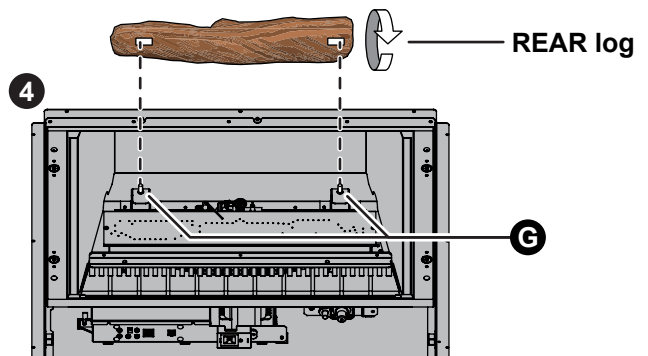
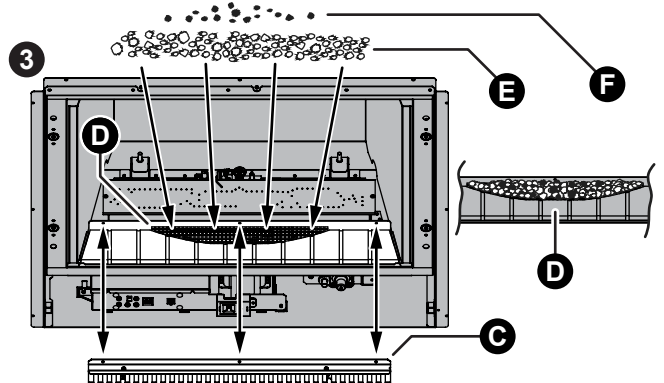
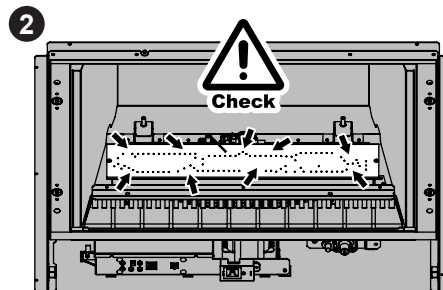
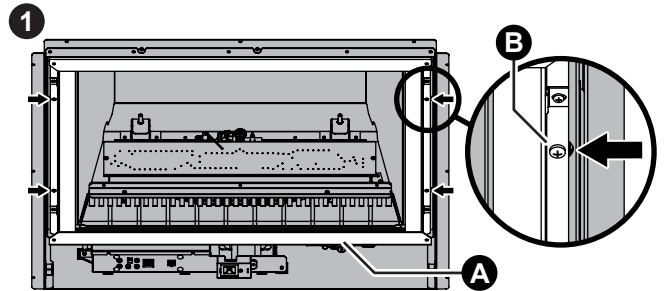

Step 5. Charcoal Bed Installation

The charcoal bed is placed directly onto the burner (I).
 For the RDV700 you will need use both bags of the black burner granules (F), while for the RDV600 approximately only one and three quarter bags worth.
 The brown burner fibre (H) will need to be pinched into approximately ten cent piece sized tufts.
 To produce the best flame effect results, in a random manner carefully place the black burner granules (F) and the brown burner fibre tufts (H) loosely across the entire surface of the burner (I).

Allowing the burner media to sit over and around the burner ports, will ensure that the flames from the gas jets are diffused, which reduces any 'candling' effect of the flame while also enhancing the realistic log burning look of the heater.

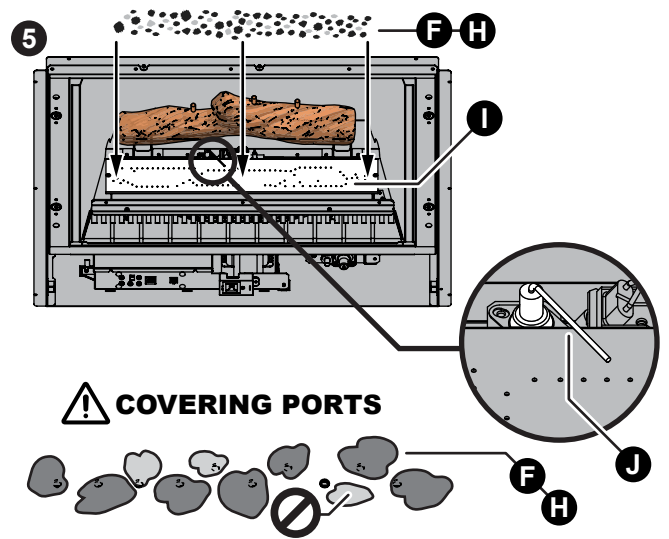

IMPORTANT  **DO NOT** force any granular or fibrous materials into the burner ports or completely block any of the burner ports.
 Keep the flame probe (J) free of any direct contact with any of the burner media.

Step 6. FRONT log Installation

Identify the "FRONT" log and then carefully remove it from the protective packaging.

Locate the two slots in the base of the log and carefully place these over the positioning pins (K) which are part of the stone guard (C), ensuring that the detailed surface of the log is facing out to the front.

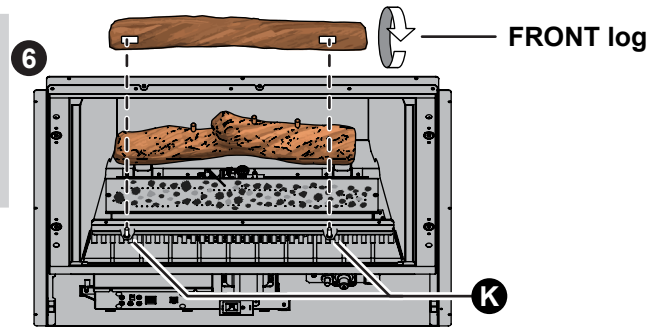

Step 7. LEFT, MIDDLE & RIGHT log Installation

Identify the "LEFT" log and then carefully remove it from the protective packaging.

Locate the two slots in the base of this log, noting that the long slot is the rear most slot, and carefully place these slots over the set of two left outermost positioning pins located on both the "FRONT" and "REAR" logs.

Identify the "MIDDLE" log and then carefully remove it from the protective packaging.

Locate the two slots in the base of this log, noting that the long slot is the rear most slot, and carefully place these slots over the set of two central positioning pins located on both the "FRONT" and "REAR" logs.

Finally carefully remove the "RIGHT" log from the protective packaging.

Locate the two slots in the base of this log, noting that the long slot is the rear most slot, and carefully place these slots over the set of two right outermost positioning pins located on both the "FRONT" and "REAR" logs.

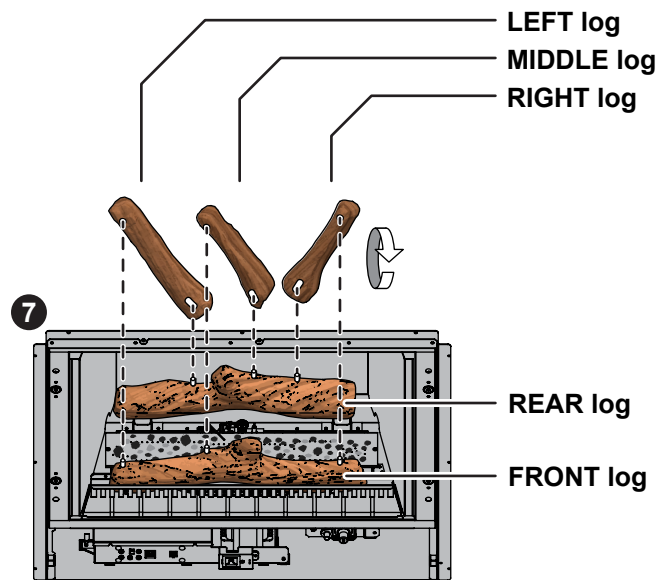

Step 8. Replacing the Burner Box Glass

Replace burner box glass panel assembly in the reverse sequence to that explained in Step 1. on page 26.

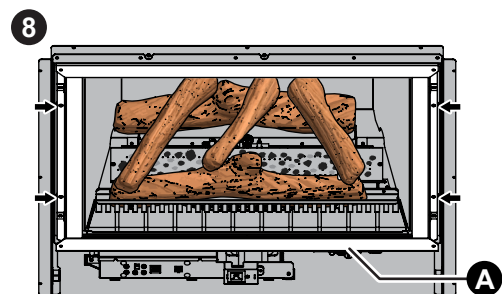

CERAMIC STONE SET INSTALLATION

Carefully unpack and inspect each stone for damage one at a time, temporarily returning each of the stones to the packaging for safe keeping until required. If **ANY** damage is evident on the stones **DO NOT** continue with installation and contact your supplier for advice.

Complete steps 1 through 3 of the "Ceramic Log Set Installation" on page 26

Step 4 . Remove Log Positioning Pins

When installing stones it is necessary to remove the Log locating pins as follows.

The front pins **(A)** are held into the stone guard by a single screw, undoing this screw will allow each pin to be removed.

The rear pins are mounted to support brackets **(B)**, each support bracket is attached to the burner box floor with two screws. The entire pin/bracket assembly for the pins is to be removed. However, the four fixing screws for the support brackets **MUST** be screwed back into the floor of the burner box.



Once removed place all the pin components in a safe place as they will be required if a log set is to be installed in the future.

Step 5. Stone Placement

A set of instructions is attached to the burner box glass has pictures of the suggested stone media placement, use these pictures as a basic guide to the stone placement, the key element to good stone placement is the avoidance of repetitive patterns, be this due to shape and or colour.

Step 6 . Charcoal Bed Installation

Use the same method described on 27 Step 5. Charcoal Bed Installation to place the black burner granules and the brown burner fibre around the stones onto the burner.



DO NOT force any granular or fibrous materials into the burner ports or completely block any of the burner ports.

Keep the flame probe media **(C)** free of any direct contact with any of the burner media.

Step 7 . Replacing the Burner Box Glass

Replace burner box glass panel assembly in the reverse sequence to that explained on 26 in Step 1. Removing the Burner Box Glass.

GENERAL INFORMATION



**HAZARDOUS VOLTAGE.
Risk of Electrical Shock.**



Disconnect all sources of supply prior to servicing



Step 1. Unpack the Fascia

For commissioning, the control panel located on the fascia will need to be connected to the communication cable of the heater engine.

The Fascia Assembly is supplied in a separate carton, check to ensure you have all the contents as listed on "CARTON CONTENTS / ITEM CHECKLIST" on page 4 at the start of this manual before proceeding. Remove all packaging materials and check all components for damage. If **ANY** damage is evident **DO NOT** install or operate this appliance. Contact your supplier for advice.

Step 2. Connect Push Button Control

Carefully pick up fascia assembly, and position the fascia close to the heater engine.

Connect the RJ45 plug **(A)** into the socket **(B)** located on the back of fascia on the bottom left hand corner, (this connects the push button control panel via a communications cable to the heater engine's control box).

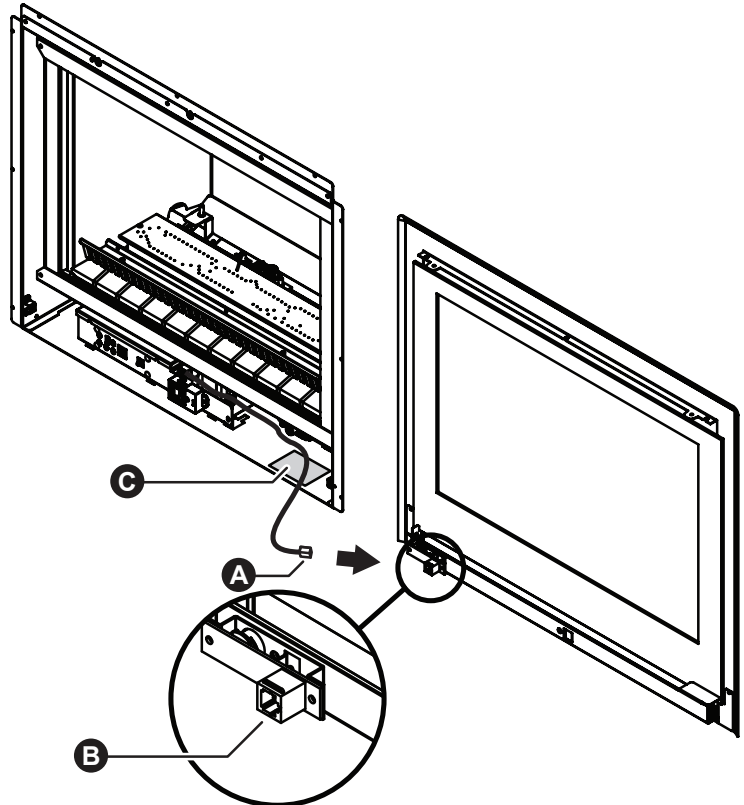

Carefully lean the fascia up against a wall, placing the card board carton between the fascia and the wall will protect both the wall and the fascia from being damaged while completing the heater commissioning.

Step 3. Switch On the Electricity Supply



230 VOLTS, RISK OF ELECTRICAL SHOCK!

Installation and commissioning **MUST** be carried out **ONLY** by an Authorised person.

Wiring inside this appliance may be at 230V potential, when performing the commissioning, the appliance electrical power will need to be connected. Exercise **CAUTION** as there is potential for electric shock from the exposed wiring and circuitry. **DO NOT** leave the appliance unattended when power is connected and the panels are removed.

Step 4. Commission the Appliance



DO NOT test for gas leakage with an open flame.

The gas type codes and gas pressures for this appliance **MUST** be checked and set in accordance with these instructions when the appliance is installed, **OR** after the replacement of any component or reassembly after service.

Burner gas pressures and gas types are factory set.

The location of the gas control is in the air gap at the lower right hand side of the appliance.

The location of the data plate **(C)** is on the base plate of the heater engine within the air gap on the right hand side of the appliance.



Gas supply pressure is to be checked with all other gas appliances in the household running on high. Failure to check this may result in lower than recommended required gas pressures, resulting in poor performance and reduced flame effect.

Step 5. Checking Supply Pressure (Ensure gas is connected)

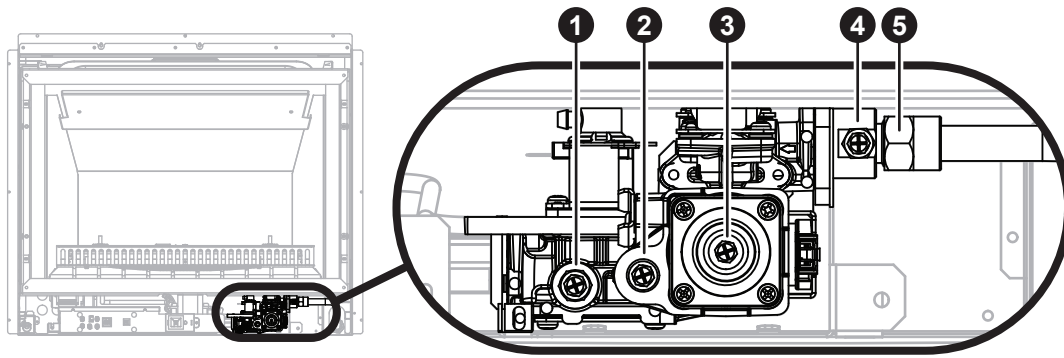

1. Remove the gas inlet test point screw **(4)**, and connect the positive pressure manometer hose. Refer to valve drawing above.
2. Press the heater ON/OFF button **(12)**, on the PCB control panel to start the ignition sequence. The appliance will ignite normally. Refer to PCB Control panel image below.

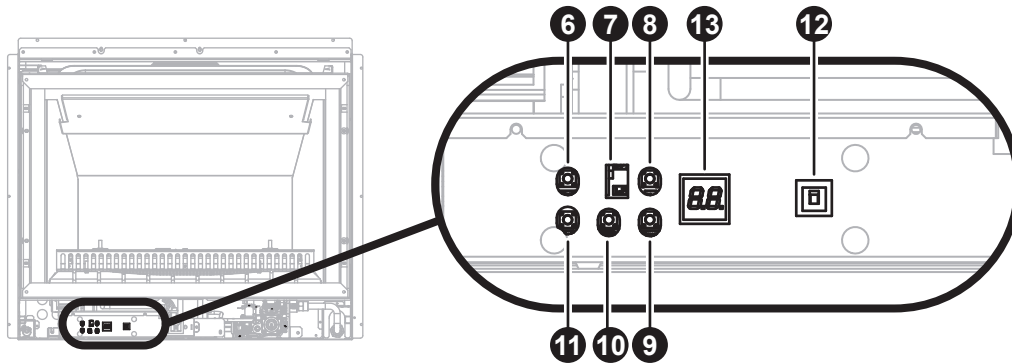

	Natural Gas	Propane Gas
Minimum Supply pressure	1.13 kPa	2.50 kPa
Maximum Supply pressure	3.50 kPa	3.00 kPa

Refer to chart for the correct gas settings, (data plate values override values printed in this instruction).

3. Check the pressures as per the chart below for the correct gas type. Ensure all other gas appliances in the household are running on 'High'
4. Press the heater ON/OFF button **(12)** to stop the appliance operation.
5. Disconnect the manometer hose and replace the inlet test point screw **(4)**. Check for leaks using soapy water solution.

Step 6. Checking and Setting burner gas pressure

1. Remove the main burner test point screw **(1)**, and connect the positive pressure manometer hose.
2. Press the heater ON/OFF button **(12)**, on the PCB control panel to start the ignition sequence. The appliance will ignite normally. Refer to PCB Control panel image above.
3. Press the 'TEST' button **(6)**, twice on the PCB control panel, the igniter will spark and the appliance will light to its lowest setting, (Main burner - stage 1), and the display **(12)**, will show P_L (stage 1).
4. Press the 'UP' button **(8)** or 'DOWN' button **(9)** to adjust to the required value if values are different to those in the table below.

Model	Natural Gas		Propane Gas	
	RDV600ER	RDV700ER	RDV600ER	RDV700ER
P_L (stage 1)	0.20 kPa	0.20 kPa	0.50 kPa	0.50 kPa
P_H (stage 7)	0.90 kPa	0.86 kPa	1.95 kPa	1.92 kPa

Refer to chart for the correct gas settings, (data plate values override values printed in this instruction).

5. Press the 'SET' button **(11)**, once to save the setting. The display **(13)**, should now be displaying P_H , (Main burner stage 7).
6. Press the 'UP' button **(8)** or 'DOWN' **(9)** button to adjust to the required value, If the pressure is already correct or when the desired pressure is achieved press the 'SET' button **(11)**, once to save the setting.
7. The display **(13)**, will now show P_L . If the display does not change to there was an error in pressure setting and the pressure setting procedure should be repeated from step 1 onward after turning the appliance 'OFF'
8. With the display **(13)**, showing P_L . Press the heater ON/OFF button **(12)**.
9. Setting main burner pressure is now complete. Remove the manometer hose and replace the inlet test point screw **(1)**. Check for leaks using soapy water solution.

Step 7. Checking and setting Pilot burner pressure

1. Remove the pilot burner gas test point screw **(2)**, and connect a positive pressure manometer hose.
2. Press the heater ON/OFF button **(12)** to start the ignition sequence, the appliance will ignite normally.
3. Press the 'TEST' button **(6)**, twice on the PCB control panel, the igniter will spark and the appliance will light to its lowest setting, (Main burner - stage 1), and the display **(13)**, will show P_L .
4. Adjust the pilot burner gas pressure to the value for the gas type as listed in the table below via the 'Pilot Burner Pressure Adjustment' screw **(3)**.

	Natural Gas	Propane Gas
Pilot Burner Pressure	1.00 kPa	2.00 kPa

Refer to chart for the correct gas settings, (data plate values override values printed in this instruction).

5. Press the heater ON/OFF button **(12)**, once to stop the appliance operation. Disconnect the manometer hose and replace the pilot burner gas test point screw **(2)**.
6. Check for gas leaks using soapy water, setting or checking pilot burner pressure is now complete.



The requirements of AS / NZS 5601 include:

- a. checking whether mechanical extraction ventilation draws air through flue systems or chimneys or not. If yes, this will most likely result in combustion product spillage from appliances during their operation.
- b. checking whether the operation of appliances and flue systems or chimneys is satisfactory.
- c. a method for determining the additional fixed ventilation area required to counteract the effect of mechanical extract ventilation.



Always check gas pressure values to those recorded on this appliances data plate, values on the data plate override values printed in this instruction.

COMMISSIONING THE APPLIANCE FOR DIFFERENT GAS TYPE



230 VOLTS, RISK OF ELECTRICAL SHOCK!

Installation and commissioning **MUST** be carried out **ONLY** by an Authorised person.

Wiring inside this appliance may be at 230V potential, when performing the commissioning, the appliance electrical power will need to be connected. Exercise **CAUTION** as there is potential for electric shock from the exposed wiring and circuitry. **DO NOT** leave the appliance unattended when power is connected and the panels are removed.

This appliance is factory set for the correct gas type as per it's gas type labelling, re-commissioning for gas type will only be required if the PCB is being replaced or if it has undergone a gas type conversion, i.e.; from NG to Propane or vice versa. Commissioning of the gas is carried out via the PCB.



Commissioning of the PCB **MUST** be carried out **BEFORE** the gas pressures are checked.

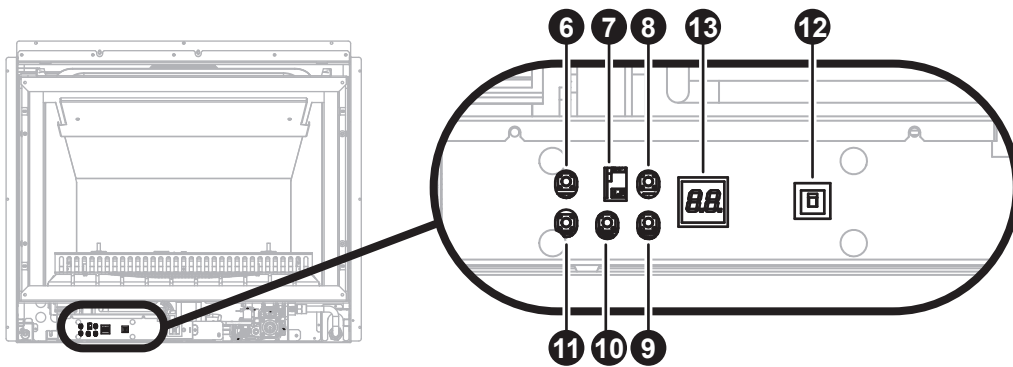

1. Turn on the gas and power supply to the appliance.
2. Press the 'UP' button or 'DOWN' button to obtain the correct gas type code for the appliance. Refer to chart to below for the correct gas type code.

Natural Gas	Propane Gas
A1	L1

3. With the appliance OFF, press the 'TEST' button, the gas type code will be shown on the display.
4. Press the 'SET' button, to lock in the code.
5. Gas pressure settings should now be checked as per “Checking and setting Pilot burner pressure” on page 28, Steps 1 through 3.

ATTACHING FASCIA ASSEMBLY

Step 8. Attach the Fascia to the Heater Engine

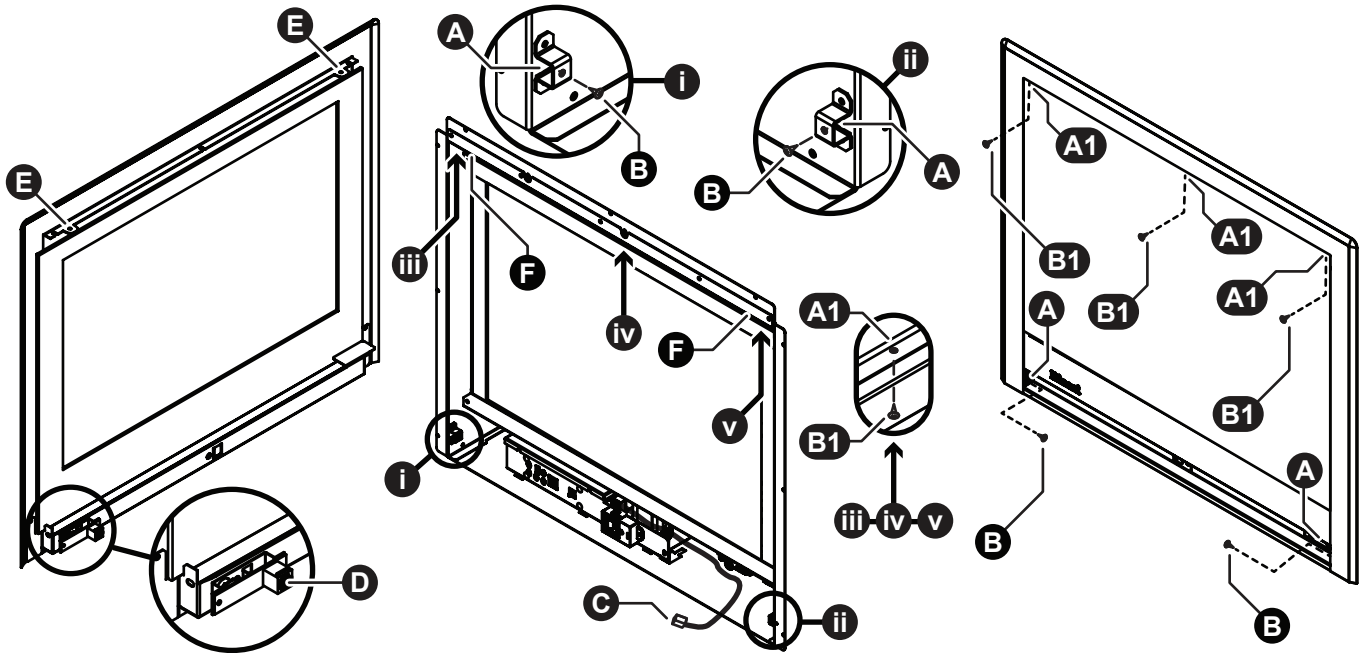

The fascia is mounted to the engine via five, **(i)**, **(ii)**, **(iii)**, **(iv)** & **(v)** mounting points. Points **(i)** & **(ii)** are fastened using 8g x 10mm sheet metal screws, **(B)**. Points, **(iii)**, **(iv)**, **(v)** are fastened using 4mm metal threaded screws, **(B1)** at points **(A1)**.



All these screws have been pre-inserted by the manufacturer to ensure correct threading of the fascia securing points. Remove screws **(B)** only prior to fitting the fascia.

- Carefully pick up fascia assembly and position it in front of the heater engine, connect the RJ45 plug **(C)** into the socket **(D)** located on the back of fascia on the bottom left hand corner, (this connects the push button control panel via a communications cable to the heater engine's control box).
- Guide the tabs **(E)**, into the fascia assembly mounting slots **(F)**.
- Ensure the three slots in the inner fascia panel have slid over all three screws **(B1)**.
- Insert the two 8g x 10mm sheet metal screws, **(B)**, through the fascia mounting holes at points, **(A)** at the bottom left and right and partially tighten.
- Fully tighten the three top screws, **(B1)** while gently pushing the fascia against the appliance to ensure a close fit, a 7mm open ended spanner will be needed.
- Gently push the fascia at the bottom corners while fully tightening the two screws, **(B)**.
- Fitting the fascias is now complete.



Ensure you **DO NOT** place excessive tension on or pinch the communication cable **(C)** when manoeuvring the fascia into position.



The glass of the fascia fitted to this appliance reduces the risk of fire and injury and no part of it should be permanently removed.

For protection of young children or the infirm a secondary guard is required.

BURN MEDIA INSTALLATION



If the heater is not operating correctly refer to the “TROUBLE SHOOTING CHECKLIST” section of the Operational Manual on page 14 before contacting Rinnai.

It is the responsibility of the installer to check that under normal operating conditions of the appliance, all flue gases are exhausted to the outside atmosphere and that there is no spillage of combustion gases into the room. Please refer to AS/NZS 5601.

During the initial burning in period of approximately 2 hours, some minor smoke and smell may be experienced. During this period the heater should be operated on High and the space being heated should be well ventilated. It may take up to 20 minutes of operation for the logs to achieve their full flame pattern and glow.

Burner aerations are factory set and can **NOT** be adjusted. If you are unable to get the unit to operate correctly refer to the Operation Manual “TROUBLE SHOOTING CHECKLIST” on page 14 before contacting Rinnai.

Malfunions due to incorrect burn media placement are **NOT** covered by warranty.

The appliance **MUST NEVER** be used with other burn media or burn media that is damaged.

ABNORMAL FLAME PATTERN

Each Rinnai Gas Fire has a distinct flame pattern. The flame should look the same every time you start your heater, after an initial warm up period of approximately 15 minutes.

Abnormal flame performance and/or pattern can indicate a problem with your heater, such as blocked gas injectors, incorrectly installed / inadequate flue system or the Ceramic logs / stones and or burner media may have shifted from when the heater was first installed.

There are some warning signs that could indicate a problem. If any of the signs below occur, please contact Rinnai.

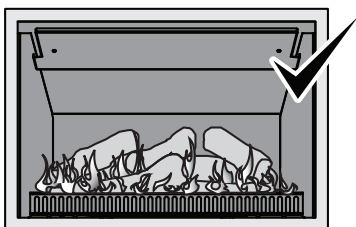

NORMAL FLAME PATTERN

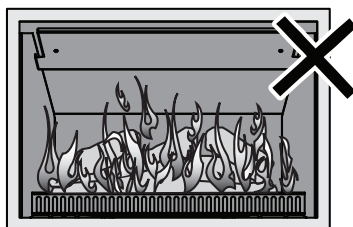

ABNORMAL FLAME PATTERN



SOOT BUILD UP

Key signs of abnormal flame performance:

- Appliance turns 'OFF' soon after start up and does not relight.
- Continued difficulty or delay in establishing a flame
- Flame appears overly orange-yellow.
- Flame appears either very short or very long.
- Flame only burns part way across the burner.
- Severe soot building up on the inside of the glass or on logs.
- Continuous unusual smell from the appliance.
- Continued difficulty or delay in establishing a flame.



Be advised that appliances incorporating a live fuel effect, and designed to operate with luminous flames, may exhibit slight carbon deposition, this is normal operation.

SPECIFICATIONS

TABLE 1. APPLIANCE DETAILS

Model	Rinnai 650 (RDV600ER)	Rinnai 750 (RDV700ER)
Features	Inbuilt Gas Space Heater Burning Log effect or Stone Fire Bed Effect Glass front Convection Fan, top warm air outlet Glass dress guard Infra Red (IR) remote control	
Data Plate	Located on the lower RHS of the base panel in front of the gas control.	
Input	12~23 MJ/h	14~27 MJ/h
Output (High)	5.2* kW	6.1* kW
Efficiency	79.4% (on high)	77.4% (on high)
Heating area	up to 78 m ² **	up to 91 m ² **
Note: * will vary accordingly to gas type and flue configuration. ** will vary depending to geographical location.		
Installation Types	Masonry Fireplace, False Fireplace and Inbuilt (weather proof box).	
Combustion Method	Bunsen type burner	
Flue - Masonry	Co-linear flexi flue, air intake Ø75mm, exhaust Ø100mm. Appliance MUST BE installed with a Rinnai flue System.	
Flueing - False Chimney	Co-linear (air intake Ø75mm, exhaust Ø100mm) to Coaxial direct vent flueing (inner Ø100mm, outer Ø170mm). Appliance must be installed with a Rinnai flue System.	
Convection Fan	120V AC 50 Hz-2-speed centrifugal blower	
Gas Connection	Brass 1/2" BSPT male fitting, the gas supply terminates inside the heater - lower right hand side of the appliance.	
Gas Type	NG, Propane, Universal LPG (Universal LPG, New Zealand Only).	
Electrical	This heater has a 1.5 m power cord with a three pin plug supplied, the power cord passes through a slot in the back right hand corner of the appliance.	
Ignition	230-240 V AC 50 Hz high voltage electronic spark ignition	
Power Consumption	When on High, 115W	
	When on Standby, less than 1W	
Safety Devices	Overheat Switch Pressure relief on glass panel - burner box Thermal Fuse, over-current fuse Flame Failure Sensing System Refer to "SAFETY DEVICES" on page 7 of the Operation Manual for information regarding additional safety devices and features.	
Glass - Primary Glass - Secondary Glass seal material	Ceramic Glass Tempered Glass Woven fibreglass chord	
Lighting	Halogen Lamps 230 V 25W x 2.	
Weight (Engine Only)	51 Kg - "un-crated" - no Flue.	55 Kg - "un-crated" - no Flue.
Operation	Push button control panel, Infra Red Remote Control.	
Noise Level	37~45 dB(A)	



Refer to appliance data plate for Gas Type, Gas Rates, Injector Sizes and Burner Pressures.

SPECIFICATIONS

TABLE 2. DIMENSIONS

MODEL	FASCIA	External Dimensions - Flue Centre											Gas Connection		
		A	B	C	D	E	F	G	H	I	J	K	L	M	N
RDV600ER	3 Sided	640	620	380	7	580	595	220	270	310	570	50	18	265	80
RDV600ER	4 Sided		645								595				
RDV700ER	3 Sided	740	620	380	7	680	595	220	340	340	570	50	18	312	80
RDV700ER	4 Sided		645								595				

All dimensions are in mm

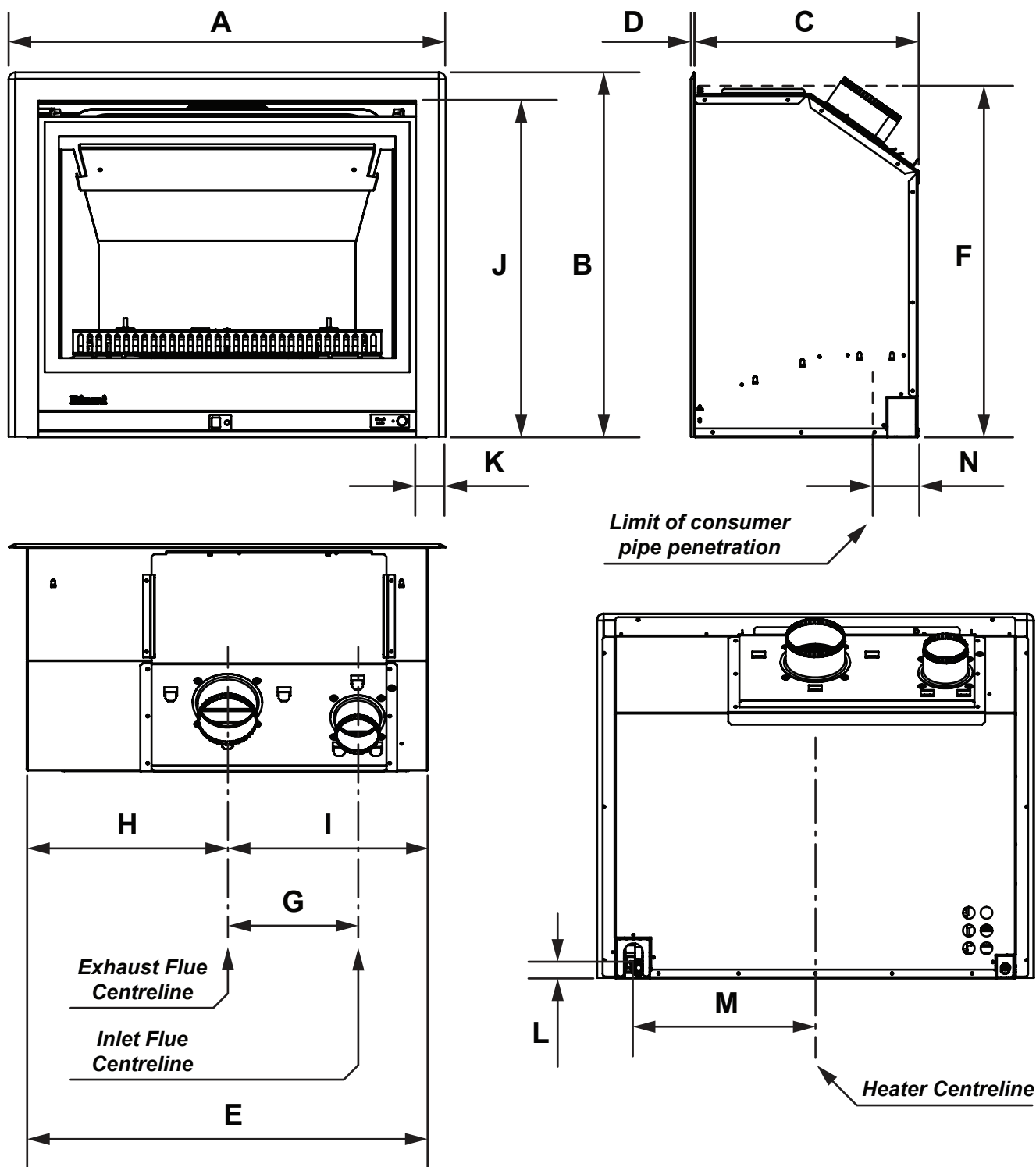

Note: RDV700ER with three sided fascia shown for illustrative purposes

WIRING DIAGRAM

Mark	Part
B	Burner
ER	Electrode
F	Fuse Electrical
FM	Convection Fan Motor
FR1-2	Flame Rod 1-2
L	Light
OH.TH1	Over Heat Thermistor
PB	Pilot Burner
POV	Modulated Solenoid Valve
R.TH	Room Thermistor
RCR	Remote Control Circuit
SP	Sparker
SV1-3	Main Solenoid Valve 1-3
TF	Thermal Fuse
TR	Transformer

Mark	Colour
bk	black
bl	blue
gr/y	yellow-Green stripe
gy	grey
or	orange
pl	purple
r	red
w	white
y	yellow
p	pink
br	brown

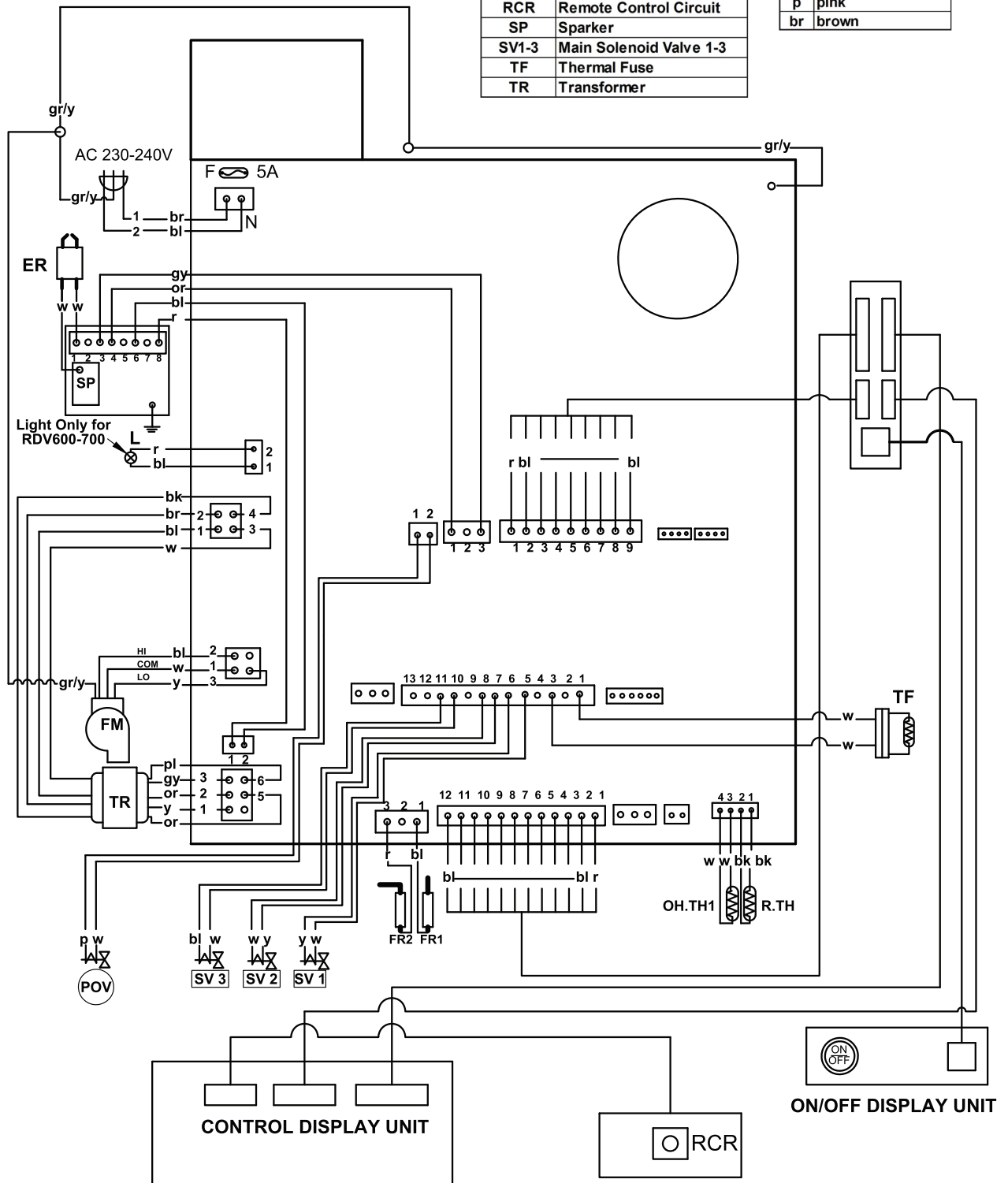

WIRING DIAGRAM UNI CONTROL MODEL 3
1 Burner
Issue B

NOTES



Rinnai Australia Pty Ltd

ABN 74 005 138 769 | AU45204

100 Atlantic Drive, Keysborough, Victoria 3173
P.O. Box 460, Braeside, Victoria 3195
Tel: (03) 9271 6625
Fax: (03) 9271 6622

National Help Line

Tel: 1300 555 545* Fax: 1300 555 655
Monday to Friday, 8.00 am to 5.00 pm EST.

**Cost of a local call higher from mobile or public phones.*

For further information visit www.rinnai.com.au
or email enquiry@rinnai.com.au

Rinnai has a Service and Spare Parts network with personnel who are fully trained and equipped to give the best service on your Rinnai appliance. If your appliance requires service, please call our National Help Line. Rinnai recommends that this appliance be serviced every 2 years.

With our policy of continuous improvement, we reserve the right to change, or discontinue at any time, specifications or designs without notice.